



# BladeCenter HS23E Blade Server Problem Determination and Service Guide



**Machine Types:** 8038, 8039

**Note**

Before using this information and the product it supports, read the general information in Appendix B “Notices” on page 207, the *Warranty Information* document, and the *IBM Safety Information* and the *Environmental Notices and User Guide* documents on the *IBM Documentation CD*.

**The most recent version of this document is available at <http://www.ibm.com/supportportal>.**

**Tenth Edition (June 2014)**

© Copyright Lenovo 2012, 2015.

**LIMITED AND RESTRICTED RIGHTS NOTICE:** If data or software is delivered pursuant a General Services Administration “GSA” contract, use, reproduction, or disclosure is subject to restrictions set forth in Contract No. GS-35F-05925

---

# Contents

<b>Safety</b> . . . . .	<b>v</b>	Setting Option ROM Execution Order . . . . .	28
Guidelines for trained service technicians . . . . .	vi	Using LAN over USB to interface the IMM . . . . .	28
Inspecting for unsafe conditions . . . . .	vi	Potential conflicts with the LAN over USB interface . . . . .	28
Guidelines for servicing electrical equipment . . . . .	vii	Resolving conflicts with the IMM LAN over USB interface . . . . .	29
Safety statements . . . . .	viii	Configuring the LAN over USB interface manually . . . . .	29
Start here. . . . .	xiii	<b>Chapter 3. Parts listing</b> . . . . .	<b>33</b>
Diagnosing a problem . . . . .	xiii	Parts listing, Type 8038 and 8039 . . . . .	33
Undocumented problems . . . . .	xvi	Structural parts . . . . .	37
<b>Chapter 1. Introduction</b> . . . . .	<b>1</b>	<b>Chapter 4. Removing and replacing blade server components.</b> . . . . .	<b>39</b>
Related documentation . . . . .	1	Installation guidelines . . . . .	39
Notices and statements in this document . . . . .	2	System reliability guidelines. . . . .	40
Features and specifications. . . . .	2	Handling static-sensitive devices . . . . .	40
Blade server controls and LEDs . . . . .	3	Returning a device or component . . . . .	40
Turning on the blade server. . . . .	6	Removing the blade server from the BladeCenter unit . . . . .	41
Turning off the blade server. . . . .	7	Installing the blade server in a BladeCenter unit. . . . .	41
Blade server system-board layouts. . . . .	7	Removing and replacing consumable and structural parts . . . . .	43
Blade server connectors . . . . .	7	Removing the blade server cover . . . . .	43
System-board switch . . . . .	8	Installing the blade server cover . . . . .	44
System-board LEDs. . . . .	9	Removing the bezel assembly . . . . .	45
<b>Chapter 2. Configuring the blade server</b> . . . . .	<b>11</b>	Installing the bezel assembly . . . . .	46
Using the Setup utility . . . . .	11	Removing a blade handle . . . . .	47
Setup utility menu . . . . .	12	Installing a blade handle . . . . .	48
Using passwords . . . . .	16	Removing the air baffle . . . . .	48
Using the Boot Menu program. . . . .	16	Installing the air baffle . . . . .	49
Updating the Universal Unique Identifier (UUID) . . . . .	16	Removing and replacing Tier 1 customer replaceable units (CRUs). . . . .	50
Updating the DMI/SMBIOS data . . . . .	18	Removing the battery . . . . .	51
Using the ServerGuide Setup and Installation CD . . . . .	21	Installing the battery. . . . .	51
ServerGuide features . . . . .	21	Removing a hot-swap storage drive . . . . .	53
Setup and configuration overview . . . . .	22	Installing a hot-swap storage drive . . . . .	53
Installing the operating system . . . . .	22	Removing a memory module . . . . .	54
Setting the PXE boot protocol using the Setup utility . . . . .	23	Installing a memory module. . . . .	55
Updating firmware and device drivers . . . . .	23	Removing a USB Flash key . . . . .	59
Configuring UEFI compatible devices. . . . .	24	Installing a USB Flash key . . . . .	59
Configuring the Gigabit Ethernet controller. . . . .	25	Removing an I/O expansion card. . . . .	60
Creating an array using the ServeRAID H1135 configuration utility . . . . .	25	Installing an I/O expansion card . . . . .	62
Starting the LSI Configuration Utility program . . . . .	26	Removing a storage interface card . . . . .	64
Starting the Human Interface Infrastructure (HII) Configuration Application. . . . .	26	Installing a storage interface card . . . . .	65
Creating a RAID array of hard disk drives . . . . .	26	Removing the control panel. . . . .	66
Creating an array using the ServeRAID C105 configuration utility . . . . .	27	Installing the control panel . . . . .	67

Removing an optional expansion unit . . . . .	68	Optical drive self tests . . . . .	186
Installing an optional expansion unit . . . . .	69	Storage drive self tests . . . . .	191
Removing and replacing Tier 2 CRUs . . . . .	70	Tape alert flags . . . . .	191
Removing a microprocessor and heat sink . . . . .	70	Recovering from a UEFI update failure . . . . .	192
Installing a microprocessor and heat sink . . . . .	73	In-band manual recovery method . . . . .	192
Removing the system-board assembly . . . . .	78	Out-of-band manual recovery method . . . . .	193
Installing the system-board assembly . . . . .	79	In-band automated boot recovery method . . . . .	195
		Out-of-band automated boot recovery method . . . . .	195
<b>Chapter 5. Diagnostics . . . . .</b>	<b>83</b>	Automated boot recovery (ABR) . . . . .	195
Service bulletins . . . . .	83	Nx boot failure . . . . .	196
Checkout procedure . . . . .	83	Solving SAS hard disk drive problems . . . . .	196
About the checkout procedure . . . . .	83	Solving shared BladeCenter resource problems . . . . .	196
Performing the checkout procedure . . . . .	84	Keyboard or mouse problems . . . . .	197
Diagnostic tools overview . . . . .	84	Media tray problems . . . . .	197
POST . . . . .	85	Network connection problems . . . . .	198
Event logs . . . . .	85	Power problems . . . . .	199
UEFI/POST error codes . . . . .	87	Video problems . . . . .	199
IMM error messages . . . . .	109	Solving undetermined problems . . . . .	200
Troubleshooting tables . . . . .	150	Problem determination tips . . . . .	201
General problems . . . . .	151		
Hard disk drive problems . . . . .	151	<b>Appendix A. Getting help and technical assistance . . . . .</b>	<b>203</b>
Intermittent problems . . . . .	152	Before you call . . . . .	203
Keyboard or mouse problems . . . . .	152	Using the documentation . . . . .	204
Memory problems . . . . .	153	Getting help and information from the World Wide Web . . . . .	204
Monitor or video problems . . . . .	154	How to send DSA data to IBM . . . . .	204
Network connection problems . . . . .	155	Creating a personalized support web page . . . . .	204
Optional-device problems . . . . .	156	Software service and support . . . . .	204
Power error messages . . . . .	156	Hardware service and support . . . . .	205
Power problems . . . . .	159	IBM Taiwan product service . . . . .	205
Removable-media drive problems . . . . .	161		
ServerGuide problems . . . . .	162	<b>Appendix B. Notices . . . . .</b>	<b>207</b>
Service processor problems . . . . .	163	Trademarks . . . . .	207
Software problems . . . . .	163	Important notes . . . . .	208
Universal Serial Bus (USB) port problems . . . . .	164	Particulate contamination . . . . .	208
Light path diagnostics . . . . .	164	Documentation format . . . . .	209
Viewing the light path diagnostics LEDs in the blade server . . . . .	164	Telecommunication regulatory statement . . . . .	210
Blade server light path diagnostics LEDs . . . . .	166	Electronic emission notices . . . . .	210
BladeCenter GPU expansion unit LED . . . . .	168	Federal Communications Commission (FCC) statement . . . . .	210
BladeCenter GPU expansion unit light path diagnostics LEDs . . . . .	168	Industry Canada Class A emission compliance statement . . . . .	210
IBM Dynamic System Analysis Preboot diagnostic program . . . . .	170	Avis de conformité à la réglementation d'Industrie Canada . . . . .	210
Running the diagnostic programs . . . . .	170	Australia and New Zealand Class A statement . . . . .	210
Diagnostic text messages . . . . .	171	European Union EMC Directive conformance statement . . . . .	210
Viewing the test results . . . . .	171	Germany Class A statement . . . . .	211
Diagnostic messages . . . . .	171	Japan VCCI Class A statement . . . . .	212
IMM self tests . . . . .	172		
Broadcom Ethernet device tests . . . . .	175		
CPU stress tests . . . . .	178		
Memory self tests . . . . .	180		

---

Japan Electronics and Information Technology Industries Association (JEITA) statement . . .	212
Korea Communications Commission (KCC) statement . . . . .	212
Russia Electromagnetic Interference (EMI) Class A statement . . . . .	212

People's Republic of China Class A electronic emission statement . . . . .	212
Taiwan Class A compliance statement . . . . .	213

<b>Index. . . . .</b>	<b>215</b>
-----------------------	------------



---

## Safety

Before installing this product, read the Safety Information.

قبل تركيب هذا المنتج، يجب قراءة الملاحظات الأمنية

Antes de instalar este produto, leia as Informações de Segurança.

在安装本产品之前，请仔细阅读 **Safety Information**  
(安全信息)。

安裝本產品之前，請先閱讀「安全資訊」。

Prije instalacije ovog produkta obavezno pročitajte Sigurnosne Upute.

Před instalací tohoto produktu si přečtěte příručku bezpečnostních instrukcí.

Læs sikkerhedsforskrifterne, før du installerer dette produkt.

Lees voordat u dit product installeert eerst de veiligheidsvoorschriften.

Ennen kuin asennat tämän tuotteen, lue turvaohjeet kohdasta Safety Information.

Avant d'installer ce produit, lisez les consignes de sécurité.

Vor der Installation dieses Produkts die Sicherheitshinweise lesen.

Πριν εγκαταστήσετε το προϊόν αυτό, διαβάστε τις πληροφορίες ασφάλειας  
(safety information).

לפני שתתקינו מוצר זה, קראו את הוראות הבטיחות.

A termék telepítése előtt olvassa el a Biztonsági előírásokat!

Prima di installare questo prodotto, leggere le Informazioni sulla Sicurezza.

製品の設置の前に、安全情報をお読みください。

본 제품을 설치하기 전에 안전 정보를 읽으십시오.

Пред да се инсталира овој продукт, прочитајте информацијата за безбедност.

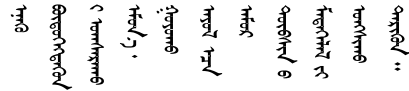

Les sikkerhetsinformasjonen (Safety Information) før du installerer dette produktet.

Przed zainstalowaniem tego produktu, należy zapoznać się  
z książką "Informacje dotyczące bezpieczeństwa" (Safety Information).

Antes de instalar este produto, leia as Informações sobre Segurança.

Перед установкой продукта прочтите инструкции по технике безопасности.

Pred inštaláciou tohto zariadenia si pečítajte Bezpečnostné predpisy.

Pred namestitvijo tega proizvoda preberite Varnostne informacije.

Antes de instalar este producto, lea la información de seguridad.

Läs säkerhetsinformationen innan du installerar den här produkten.

ཐོན་རྒྱུ་འདི་བདེ་སྤྱོད་མ་བྱས་གོང་། རྒྱུ་ལྷོ་ལྷོ་ཡི་གཟུགས་  
བྱ་འདྲ་མིན་ཡོད་པའི་འོད་སྤེར་བལྟ་དགོས།

Bu ürünü kurmadan önce güvenlik bilgilerini okuyun.

مەزكۇر مەھسۇلاتنى ئورنىتىشتىن بۇرۇن بىخەتەرلىك ئۇچۇرلىرىنى ئوقۇپ چىقىڭ.

Youq mwngz yungh canjbinj neix gaxgonq, itdingh aeu doeg aen  
canjbinj soengq cungj vahgangj ancien siusik.

---

## Guidelines for trained service technicians

This section contains information for trained service technicians.

### Inspecting for unsafe conditions

Use this information to help you identify potential unsafe conditions in an IBM product that you are working on.

Each IBM product, as it was designed and manufactured, has required safety items to protect users and service technicians from injury. The information in this section addresses only those items. Use good judgment to identify potential unsafe conditions that might be caused by non-IBM alterations or attachment of non-IBM features or optional devices that are not addressed in this section. If you identify an unsafe condition, you must determine how serious the hazard is and whether you must correct the problem before you work on the product.

Consider the following conditions and the safety hazards that they present:

- Electrical hazards, especially primary power. Primary voltage on the frame can cause serious or fatal electrical shock.
- Explosive hazards, such as a damaged CRT face or a bulging capacitor.
- Mechanical hazards, such as loose or missing hardware.

To inspect the product for potential unsafe conditions, complete the following steps:

1. Make sure that the power is off and the power cords are disconnected.
2. Make sure that the exterior cover is not damaged, loose, or broken, and observe any sharp edges.
3. Check the power cords:
  - Make sure that the third-wire ground connector is in good condition. Use a meter to measure third-wire ground continuity for 0.1 ohm or less between the external ground pin and the frame ground.
  - Make sure that the power cords are the correct type.
  - Make sure that the insulation is not frayed or worn.



4. Remove the cover.
5. Check for any obvious non-IBM alterations. Use good judgment as to the safety of any non-IBM alterations.
6. Check inside the system for any obvious unsafe conditions, such as metal filings, contamination, water or other liquid, or signs of fire or smoke damage.
7. Check for worn, frayed, or pinched cables.
8. Make sure that the power-supply cover fasteners (screws or rivets) have not been removed or tampered with.

## **Guidelines for servicing electrical equipment**

Observe these guidelines when you service electrical equipment.

- Check the area for electrical hazards such as moist floors, nongrounded power extension cords, and missing safety grounds.
- Use only approved tools and test equipment. Some hand tools have handles that are covered with a soft material that does not provide insulation from live electrical current.
- Regularly inspect and maintain your electrical hand tools for safe operational condition. Do not use worn or broken tools or testers.
- Do not touch the reflective surface of a dental mirror to a live electrical circuit. The surface is conductive and can cause personal injury or equipment damage if it touches a live electrical circuit.
- Some rubber floor mats contain small conductive fibers to decrease electrostatic discharge. Do not use this type of mat to protect yourself from electrical shock.
- Do not work alone under hazardous conditions or near equipment that has hazardous voltages.
- Locate the emergency power-off (EPO) switch, disconnecting switch, or electrical outlet so that you can turn off the power quickly in the event of an electrical accident.
- Disconnect all power before you perform a mechanical inspection, work near power supplies, or remove or install main units.
- Before you work on the equipment, disconnect the power cord. If you cannot disconnect the power cord, have the customer power-off the wall box that supplies power to the equipment and lock the wall box in the off position.
- Never assume that power has been disconnected from a circuit. Check it to make sure that it has been disconnected.
- If you have to work on equipment that has exposed electrical circuits, observe the following precautions:
  - Make sure that another person who is familiar with the power-off controls is near you and is available to turn off the power if necessary.
  - When you work with powered-on electrical equipment, use only one hand. Keep the other hand in your pocket or behind your back to avoid creating a complete circuit that could cause an electrical shock.
  - When you use a tester, set the controls correctly and use the approved probe leads and accessories for that tester.
  - Stand on a suitable rubber mat to insulate you from grounds such as metal floor strips and equipment frames.
- Use extreme care when you measure high voltages.
- To ensure proper grounding of components such as power supplies, pumps, blowers, fans, and motor generators, do not service these components outside of their normal operating locations.
- If an electrical accident occurs, use caution, turn off the power, and send another person to get medical aid.

---

## Safety statements

These statements provide the caution and danger information that is used in this documentation.

**Important:** Each caution and danger statement in this documentation is labeled with a number. This number is used to cross reference an English-language caution or danger statement with translated versions of the caution or danger statement in the *Safety Information* document.

For example, if a caution statement is labeled Statement 1, translations for that caution statement are in the *Safety Information* document under Statement 1.

Be sure to read all caution and danger statements in this documentation before you perform the procedures. Read any additional safety information that comes with your system or optional device before you install the device.

### Statement 1



**Electrical current from power, telephone, and communication cables is hazardous.**

**To avoid a shock hazard:**

- **Do not connect or disconnect any cables or perform installation, maintenance, or reconfiguration of this product during an electrical storm.**
- **Connect all power cords to a properly wired and grounded electrical outlet.**
- **Connect to properly wired outlets any equipment that will be attached to this product.**
- **When possible, use one hand only to connect or disconnect signal cables.**
- **Never turn on any equipment when there is evidence of fire, water, or structural damage.**
- **Disconnect the attached power cords, telecommunications systems, networks, and modems before you open the device covers, unless instructed otherwise in the installation and configuration procedures.**
- **Connect and disconnect cables as described in the following table when installing, moving, or opening covers on this product or attached devices.**

**To Connect:**

1. Turn everything OFF.
2. First, attach all cables to devices.
3. Attach signal cables to connectors.
4. Attach power cords to outlet.
5. Turn device ON.

**To Disconnect:**

1. Turn everything OFF.
2. First, remove power cords from outlet.
3. Remove signal cables from connectors.
4. Remove all cables from devices.

## Statement 2



### CAUTION:

When replacing the lithium battery, use only IBM Part Number 33F8354 or an equivalent type battery recommended by the manufacturer. If your system has a module containing a lithium battery, replace it only with the same module type made by the same manufacturer. The battery contains lithium and can explode if not properly used, handled, or disposed of.

*Do not:*

- Throw or immerse into water
- Heat to more than 100°C (212°F)
- Repair or disassemble

Dispose of the battery as required by local ordinances or regulations.

## Statement 3



### CAUTION:

When laser products (such as CD-ROMs, DVD drives, fiber optic devices, or transmitters) are installed, note the following:

- Do not remove the covers. Removing the covers of the laser product could result in exposure to hazardous laser radiation. There are no serviceable parts inside the device.
- Use of controls or adjustments or performance of procedures other than those specified herein might result in hazardous radiation exposure.



**DANGER**

Some laser products contain an embedded Class 3A or Class 3B laser diode. Note the following.

Laser radiation when open. Do not stare into the beam, do not view directly with optical instruments, and avoid direct exposure to the beam.

Class 1 Laser Product

Laser Klasse 1

Laser Klass 1

Luokan 1 Laserlaite

Appareil À Laser de Classe 1

**Statement 4**



**CAUTION:** Use safe practices when lifting.

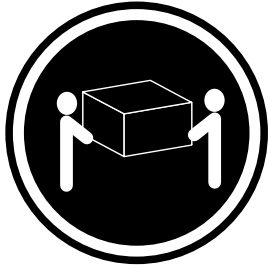

≥ 18 kg (39.7 lb)

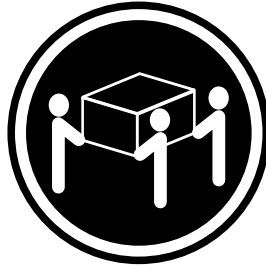

≥ 32 kg (70.5 lb)

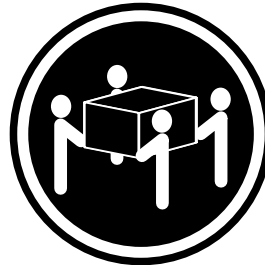

≥ 55 kg (121.2 lb)

**Statement 8**



**CAUTION:**

Never remove the cover on a power supply or any part that has the following label attached.



Hazardous voltage, current, and energy levels are present inside any component that has this label attached. There are no serviceable parts inside these components. If you suspect a problem with one of these parts, contact a service technician.

**Statement 12**



**CAUTION:**

The following label indicates a hot surface nearby.



Statement 13



 DANGER

Overloading a branch circuit is potentially a fire hazard and a shock hazard under certain conditions. To avoid these hazards, ensure that your system electrical requirements do not exceed branch circuit protection requirements. Refer to the information that is provided with your device for electrical specifications.

Statement 21



CAUTION:

Hazardous energy is present when the blade is connected to the power source. Always replace the blade cover before installing the blade.

Statement 32



CAUTION:

To avoid personal injury, before lifting the unit, remove all the blades, power supplies, and removable modules to reduce the weight.

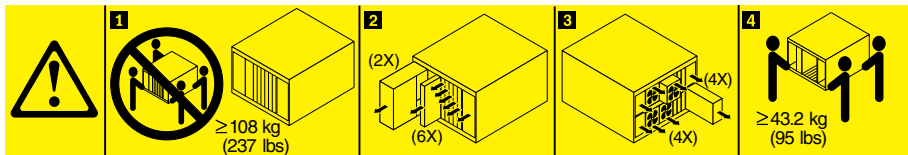

Statement 33



CAUTION: This device does not provide a power control button. Removing power supply modules or turning off the server blades does not turn off the electrical current supplied to the device. The device also might have more than one power cord. To remove all electrical current from the device, ensure that all power cords are disconnected from the power source.

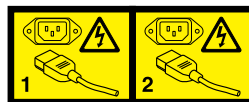
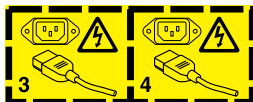

## Rack Safety Information, Statement 2



 **DANGER**

- **Always lower the leveling pads on the rack cabinet.**
- **Always install stabilizer brackets on the rack cabinet.**
- **Always install servers and optional devices starting from the bottom of the rack cabinet.**
- **Always install the heaviest devices in the bottom of the rack cabinet.**

### **UL regulatory information**

This device is for use only with Listed chassis.

---

## Start here

You can solve many problems without outside assistance by following the troubleshooting procedures in this documentation and on the World Wide Web.

This document describes the diagnostic tests that you can perform, troubleshooting procedures, and explanations of error messages and error codes. The documentation that comes with your operating system and software also contains troubleshooting information.

## Diagnosing a problem

Before you contact IBM or an approved warranty service provider, follow these procedures in the order in which they are presented to diagnose a problem with your blade server.

### Step 1. **Return the server to the condition it was in before the problem occurred.**

If any hardware, software, or firmware was changed before the problem occurred, if possible, reverse those changes. This might include any of the following items:

- Hardware components
- Device drivers and firmware
- System software
- UEFI firmware
- System input power or network connections

### Step 2. **View the light path diagnostics LEDs and event logs.**

The blade server is designed for ease of diagnosis of hardware and software problems.

- **Light path diagnostics LEDs:** See “Light path diagnostics” on page 164 for information about using light path diagnostics LEDs.
- **Event logs:** See “Event logs” on page 85 for information about notification events and diagnosis.
- **Software or operating-system error codes:** See the documentation for the software or operating system for information about a specific error code. See the manufacturer's website for documentation.

### Step 3. **Run IBM Dynamic System Analysis (DSA) and collect system data.**

Run Dynamic System Analysis (DSA) to collect information about the hardware, firmware, software, and operating system. Have this information available when you contact IBM or an approved warranty service provider. For instructions for running DSA, see the *Dynamic System Analysis Installation and User's Guide*.

To download the latest version of DSA code and the *Dynamic System Analysis Installation and User's Guide*, go to <http://www.ibm.com/support/entry/portal/docdisplay?Indocid=SERV-DSA>.

### Step 4. **Check for and apply code updates.**

Fixes or workarounds for many problems might be available in updated UEFI firmware, device firmware, or device drivers. To display a list of available updates for the blade server, go to <http://www.ibm.com/support/fixcentral>.

**Attention:** Installing the wrong firmware or device-driver update might cause the blade server to malfunction. Before you install a firmware or device-driver update, read any readme and change history files that are provided with the downloaded update. These files contain important information about the update and the procedure for installing the update, including any special procedure for updating from an early firmware or device-driver version to the latest version.

**Important:** Some cluster solutions require specific code levels or coordinated code updates. If the device is part of a cluster solution, verify that the latest level of code is supported for the cluster solution before you update the code.

a. **Install UpdateXpress system updates.**

You can install code updates that are packaged as an UpdateXpress System Pack or UpdateXpress CD image. An UpdateXpress System Pack contains an integration-tested bundle of online firmware and device-driver updates for your blade server. In addition, you can use IBM ToolsCenter Bootable Media Creator to create bootable media that is suitable for applying firmware updates and running preboot diagnostics. For more information about UpdateXpress System Packs, see <http://www.ibm.com/support/entry/portal/docdisplay?Indocid=SERV-XPRESS>. For more information about the Bootable Media Creator, see <http://www.ibm.com/support/entry/portal/docdisplay?Indocid=TOOL-BOMC>.

Be sure to separately install any listed critical updates that have release dates that are later than the release date of the UpdateXpress System Pack or UpdateXpress image (see step b. on page xiv).

b. **Install manual system updates.**

1. **Determine the existing code levels.** From the advanced management module web interface, click **Monitors** and then click **Firmware VPD**.

In DSA, click **Firmware/VPD** to view system firmware levels, or click **Software** to view operating-system levels.

2. **Download and install updates of code that is not at the latest level.** To display a list of available updates for the blade server, go to <http://www.ibm.com/support/fixcentral>.

When you click an update, an information page is displayed, including a list of the problems that the update fixes. Review this list for your specific problem; however, even if your problem is not listed, installing the update might solve the problem.

Step 5. **Check for and correct an incorrect configuration.**

If the blade server is incorrectly configured, a system function can fail to work when you enable it; if you make an incorrect change to the blade server configuration, a system function that has been enabled can stop working.

a. **Make sure that all installed hardware and software are supported.**



See <http://www.ibm.com/systems/info/x86servers/serverproven/compat/us> to verify that the blade server supports the installed operating system, optional devices, and software levels. If any hardware or software component is not supported, uninstall it to determine whether it is causing the problem. You must remove nonsupported hardware before you contact IBM or an approved warranty service provider for support.

- b. **Make sure that the server, operating system, and software are installed and configured correctly.**

Many configuration problems are caused by loose power or signal cables or incorrectly seated adapters. You might be able to solve the problem by turning off the blade server, reconnecting cables, reseating adapters, and turning the blade server back on. For information about performing the checkout procedure, see “About the checkout procedure” on page 83. For information about configuring the blade server, see Chapter 2 “Configuring the blade server” on page 11.

**Step 6. See controller and management software documentation.**

If the problem is associated with a specific function (for example, if a RAID hard disk drive is marked offline in the RAID array), see the documentation for the associated controller and management or controlling software to verify that the controller is correctly configured.

Problem determination information is available for many devices such as RAID and network adapters.

For problems with operating systems or IBM software or devices, go to <http://www.ibm.com/supportportal>.

**Step 7. Check for troubleshooting procedures and RETAIN tips.**

Troubleshooting procedures and RETAIN tips document known problems and suggested solutions. To search for troubleshooting procedures and RETAIN tips, go to <http://www.ibm.com/supportportal>.

**Step 8. Use the troubleshooting tables.**

See “Troubleshooting tables” on page 150 to find a solution to a problem that has identifiable symptoms.

A single problem might cause multiple symptoms. Follow the troubleshooting procedure for the most obvious symptom. If that procedure does not diagnose the problem, use the procedure for another symptom, if possible.

If the problem remains, contact IBM or an approved warranty service provider for assistance with additional problem determination and possible hardware replacement. To open an online service request, go to [http://www.ibm.com/support/entry/portal/Open\\_service\\_request](http://www.ibm.com/support/entry/portal/Open_service_request). Be prepared to provide information about any error codes and collected data.

## **Undocumented problems**

If you have completed the diagnostic procedure and the problem remains, the problem might not have been previously identified by IBM. After you have verified that all code is at the latest level, all hardware and software configurations are valid, and no light path diagnostics LEDs or log entries indicate a hardware component failure, contact IBM or an approved warranty service provider for assistance.

To open an online service request, go to [http://www.ibm.com/support/entry/portal/Open\\_service\\_request](http://www.ibm.com/support/entry/portal/Open_service_request). Be prepared to provide information about any error codes and collected data and the problem determination procedures that you have used.

---

## Chapter 1. Introduction

Use this information to help you solve problems that might occur in your blade server.

This *Problem Determination and Service Guide* contains information to help you solve problems that might occur in your IBM BladeCenter HS23E Type 8038 or 8039 blade server. It describes the diagnostic tools that come with the blade server, error codes and suggested actions, and instructions for replacing failing components.

Replaceable components consist of consumable parts, structural parts, and customer replaceable units (CRUs):

- **Consumables:** Purchase and replacement of consumables (components, such as batteries and printer cartridges, that have depleting life) is your responsibility. If IBM acquires or installs a consumable component at your request, you will be charged for the service.
- **Structural parts:** Purchase and replacement of structural parts (components, such as chassis assembly, top cover, and bezel) is your responsibility. If IBM acquires or installs a structural component at your request, you will be charged for the service.
- **Customer replaceable unit (CRU):**
  - **Tier 1 customer replaceable unit:** Replacement of Tier 1 CRUs is your responsibility. If IBM installs a Tier 1 CRU at your request, you will be charged for the installation.
  - **Tier 2 customer replaceable unit:** You may install a Tier 2 CRU yourself or request IBM to install it, at no additional charge, under the type of warranty service that is designated for your server. Some tier 2 CRUs must be installed only by trained technicians.

For information about the terms of the warranty and getting service and assistance, see the *Warranty Information* document.

---

## Related documentation

Use this information to identify and locate related blade server documentation.

This *Problem Determination and Service Guide* contains information to help you solve problems yourself, how to remove and install components, and it contains information for service technicians. The following documentation is also available:

- *Safety Information*

This document contains translated caution and danger statements. Each caution and danger statement that appears in the documentation has a number that you can use to locate the corresponding statement in your language in the *Safety Information* document.
- *Warranty Information*

This document contains information about the terms of the warranty.
- *Environmental Notices and User Guide*

This document contains translated environmental notices.
- *Integrated Management Module II User's Guide*

This document explains how to use the functions of the IMM2 that is installed in an IBM server. The IMM2 works with IBM UEFI firmware to provide systems-management capability for System x® servers and blade servers.

- *Advanced Management Module Messages Guide*

This document provides a complete list of all non-device specific events and recommended actions, sorted by event ID. Device specific event information is in the documentation for the device.

- *Advanced Management Module Command-Line Interface Reference Guide*

This document explains how to use the advanced management module command-line interface (CLI) to directly access the BladeCenter management functions. The command-line interface also provides access to the text-console command prompt on each blade server through a Serial over LAN (SOL) connection.

- *Advanced Management Module Messages Guide*

This document provides a complete list of all non-device-specific events and recommended actions, sorted by event ID. For event information that is specific to this blade server, see “IMM error messages” on page 109 for more information.

In addition to the documentation in this library, be sure to review the *Planning and Installation Guide* for your BladeCenter unit for information to help you prepare for system installation and configuration.

To check for updated documentation and technical updates, go to <http://www.ibm.com/supportportal/>.

---

## Notices and statements in this document

Use this information to understand the most common documentation notices and statements and how they are used.

The caution and danger statements in this document are also in the multilingual *Safety Information* document, which is on the *IBM Documentation CD*. Each statement is numbered for reference to the corresponding statement in the *Safety Information* document.

The following notices and statements are used in this document:

- **Note:** These notices provide important tips, guidance, or advice.
- **Important:** These notices provide information or advice that might help you avoid inconvenient or problem situations.
- **Attention:** These notices indicate possible damage to programs, devices, or data. An attention notice is placed just before the instruction or situation in which damage might occur.
- **Caution:** These statements indicate situations that can be potentially hazardous to you. A caution statement is placed just before the description of a potentially hazardous procedure step or situation.
- **Danger:** These statements indicate situations that can be potentially lethal or extremely hazardous to you. A danger statement is placed just before the description of a potentially lethal or extremely hazardous procedure step or situation.

---

## Features and specifications

Use this table to view specific information about the blade server, such as blade server hardware features and the dimensions of the blade server.

### Notes:

1. Power, cooling, removable-media drives, external ports, and advanced system management are provided by the BladeCenter unit.
2. The operating system in the blade server must provide USB support for the blade server to recognize and use USB media drives and devices. The BladeCenter unit uses USB for internal communications with these devices.

The following table is a summary of the features and specifications of the blade server.

Table 1. Features and specifications

<p><b>Microprocessor:</b> Supports up to two multi-core IntelXeon microprocessors.</p> <p><b>Note:</b> Use the Setup utility to determine the type and speed of the microprocessors in the blade server.</p> <p><b>Memory:</b></p> <ul style="list-style-type: none"> <li>• 12 dual inline memory module (DIMM) connectors</li> <li>• Type: Very Low Profile (VLP) double-data rate (DDR3) single-rank, dual-rank, or quad-rank DRAM</li> <li>• Supports 2 GB, 4 GB, 8 GB, and 16 GB DIMMs with up to 192 GB of total memory on the system board</li> </ul> <p><b>Integrated functions:</b></p> <ul style="list-style-type: none"> <li>• Horizontal-compact-form-factor (CFFh) expansion card interface</li> <li>• Vertical-combination-I/O (CIOv) expansion card interface</li> <li>• Local service processor: Integrated Management Module II (IMM2) with Intelligent Platform Management Interface (IPMI) firmware</li> <li>• Integrated Renesas SH7757 IMM2 video controller</li> <li>• Integrated keyboard/video/mouse (cKVM) controller through the IMM2</li> <li>• Light path diagnostics</li> <li>• RS-485 interface for communication with the management module</li> <li>• USB 2.0 for communication with cKVM and removable media drives (an external USB port is not supported)</li> <li>• Serial over LAN (SOL)</li> <li>• Wake on LAN (WOL)</li> <li>• Redundant buses for communication with keyboard, mouse, and removable media drives</li> </ul>	<p><b>Predictive Failure Analysis (PFA) alerts:</b></p> <ul style="list-style-type: none"> <li>• Memory</li> <li>• Storage drives (SAS only)</li> </ul> <p><b>Electrical input:</b> 12 V dc</p> <p><b>Environment:</b></p> <ul style="list-style-type: none"> <li>• Air temperature: <ul style="list-style-type: none"> <li>– Blade server on: 10°C to 35°C (50°F to 95°F). Altitude: 0 m to 914.4 m (0 ft to 3000 ft)</li> <li>– Blade server on: 10°C to 32°C (50°F to 89.6°F). Altitude: 914.4 m to 2133.6 m (3000 ft to 7000 ft)</li> <li>– Blade server off: 10°C to 43°C (50°F to 109.4°F). Altitude: 914.4 m to 2133.6 m (3000 ft to 7000 ft)</li> <li>– Blade server shipping: -40°C to 60°C (-40°F to 140°F)</li> </ul> </li> <li>• Humidity: <ul style="list-style-type: none"> <li>– Blade server on: 8% to 80%</li> <li>– Blade server off: 8% to 80%</li> <li>– Blade server storage: 5% to 80%</li> <li>– Blade server shipment: 5% to 100%</li> </ul> </li> <li>• Particulate contamination:</li> </ul> <p><b>Attention:</b> Airborne particulates and reactive gases acting alone or in combination with other environmental factors such as humidity or temperature might pose a risk to the server. For information about the limits for particulates and gases, see “Particulate contamination” on page 208.</p>	<p><b>Drives:</b> Supports up to two hot-swap, small form factor (SFF)</p> <ul style="list-style-type: none"> <li>• Serial Attached SCSI (SAS) (enabled when ServeRAID H1135 is installed)</li> <li>• Serial ATA (SATA) (including solid-state storage drives)</li> </ul> <p><b>Size:</b></p> <ul style="list-style-type: none"> <li>• Height: 24.5 cm (9.64 inches) (6U)</li> <li>• Depth: 44.6 cm (17.56 inches)</li> <li>• Width: 2.9 cm (1.14 inches)</li> <li>• Maximum weight: 4.63 kg (10.2 lb)</li> </ul>
--	---	---

## Blade server controls and LEDs

Use this information for details about the controls and LEDs on the blade server.

The following illustration identifies the buttons and information LEDs on the blade-server control panel.

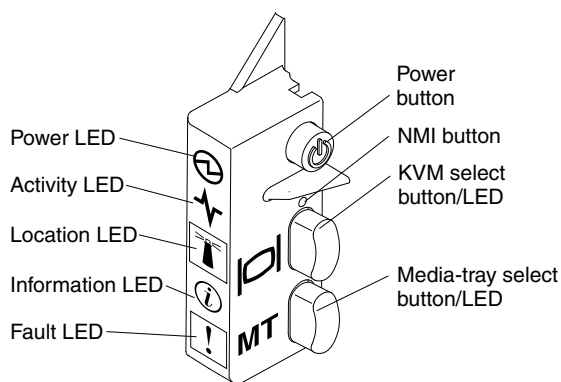

**Power LED:** This green LED indicates the power status of the blade server in the following manner:

- **Flashing rapidly:** While the service processor in the blade server is initializing and synchronizing with the management module, the power LED flashes rapidly, and the power button on the blade server does not respond. This process can take approximately two minutes after the blade server has been installed. If the LED continues to flash rapidly, the blade server might not have power permissions assigned to it through the Advanced Management Module, the BladeCenter unit does not have enough power to turn on the blade server, or the service processor (IMM) on the blade server is not communicating with the Advanced Management Module.
- **Flashing slowly:** The blade server has power supplied and is ready to be turned on.
- **Lit continuously:** The blade server has power and is turned on.

**Activity LED:** When this green LED is lit, it indicates that there is activity on the external storage device or network.

**Location LED:** The system administrator can remotely turn on this blue LED to aid in visually locating the blade server. When this LED is lit, the location LED on the BladeCenter unit is also lit. The location LED can be turned off through the Advanced-Management-Module Web interface or through IBM® Director Console. For more information about the Advanced-Management-Module Web interface, see “” on page . For more information about IBM® Director, see the documentation on the IBM® Director CD that comes with the server, or visit the IBM® Director Information Center at <http://publib.boulder.ibm.com/infocenter/director/v6r1x/index.jsp>.

**Information LED:** When this yellow LED is lit, it indicates that information about a system event in the blade server has been placed in the Advanced-Management-Module event log. The information LED can be turned off through the Advanced-Management-Module CLI, SNMP, or Web interface or through IBM Director Console. For more information about the Advanced-Management-Module web interface, see <http://www.ibm.com/systems/management/>. For more information about IBM® Director, see the documentation on the IBM® Director CD that comes with the server, or visit the IBM® Director Information Center at <http://publib.boulder.ibm.com/infocenter/director/v6r1x/index.jsp>.

**Fault LED:** When this yellow LED is lit, it indicates that a system error has occurred in the blade server. The blade-error LED turns off only after the error is corrected.

**Power button:** Press this button to turn on or turn off the blade server. When the blade server is turned off, you can press and hold the power button to light the LEDs of failing components in the blade server.

**Note:** The power button has effect only if local power control is enabled for the blade server. Local power control is enabled and disabled through the Advanced-Management-Module web interface.

**NMI button (recessed):** The nonmaskable interrupt (NMI) dumps the partition. Use this recessed button only as directed by IBM Support.

**Note:** You can also send an NMI event to the selected blade server remotely using the AMM. For more information, see the *BladeCenter Advanced Management Module User's Guide*.

**Keyboard/video/mouse (KVM) select button:** Press this button to associate the shared BladeCenter unit keyboard port, video port, and mouse port with the blade server. The LED on this button flashes while the request is being processed and then is lit when the ownership of the keyboard, video, and mouse has been transferred to the blade server. It can take approximately 20 seconds to switch the keyboard, video, and mouse control to the blade server.

Using a keyboard that is directly attached to the Advanced-Management-Module, you can press keyboard keys in the following sequence to switch KVM control between blade servers instead of using the KVM select button:

```
NumLock NumLock blade_server_number Enter
```

*blade\_server\_number* is the two-digit number of the blade-server bay in which the blade server is installed. A blade server that occupies more than one blade-server bay is identified by the lowest bay number that it occupies.

If there is no response when you press the KVM select button, you can use the Advanced-Management-Module web interface to determine whether local control has been disabled on the blade server. See <http://www.ibm.com/systems/management/> for more information.

**Notes:**

1. The operating system in the blade server must provide USB support for the blade server to recognize and use the keyboard and mouse, even if the keyboard and mouse have PS/2-style connectors.
2. If you install a supported MicrosoftWindows operating system on the blade server while it is not the current owner of the keyboard, video, and mouse, a delay of up to 1 minute occurs the first time that you switch the keyboard, video, and mouse to the blade server. All subsequent switching takes place in the normal KVM switching time frame (up to 20 seconds).

**Media-tray select button:** Press this button to associate the shared BladeCenter unit media tray (removable-media drives) with the blade server. The LED on the button flashes while the request is being processed and then is lit when the ownership of the media tray has been transferred to the blade server. It can take approximately 20 seconds for the operating system in the blade server to recognize the media tray.

If there is no response when you press the media-tray select button, you can use the Advanced-Management-Module Web interface to determine whether local control has been disabled on the blade server.

**Note:** The operating system in the blade server must provide USB support for the blade server to recognize and use the removable-media drives.

The following illustration identifies the information LEDs on the SAS hot-swap hard disk drive.

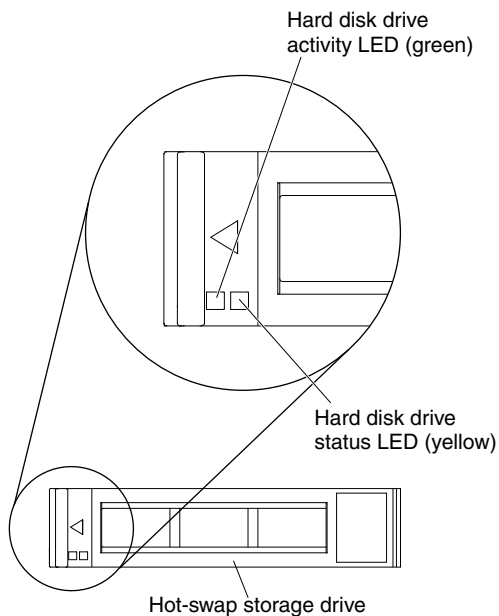

**Hard disk drive activity LED (green):** When this green LED is lit, it indicates that there is activity on the storage drive.

**Hard disk drive status LED (yellow):** When this yellow LED is lit, it indicates that an error has occurred with the storage drive. The LED turns off only after the error is corrected.

---

## Turning on the blade server

Use this information to turn on the blade server.

After you connect the blade server to power through the BladeCenter unit, the blade server can start in any of the following ways:

- You can press the power button on the front of the blade server (see “Blade server controls and LEDs” on page 3) to start the blade server.

### Notes:

1. Wait until the power LED on the blade server flashes slowly before you press the power button. While the service processor in the blade server is initializing and synchronizing with the management module, the power LED flashes rapidly, and the power button on the blade server does not respond. This process can take approximately two minutes after the blade server has been installed.
  2. While the blade server is starting, the power LED on the front of the blade server is lit and does not flash. See “Blade server controls and LEDs” on page 3 for the power LED states.
- If a power failure occurs, the BladeCenter unit and the blade server can be configured to start automatically when power is restored through the Advanced Management Module.
  - You can turn on the blade server remotely by using the management module.
  - If the blade server is connected to power (the power LED is flashing slowly), the blade server is communicating with the management module, the operating system supports the Wake on LAN feature, and the Wake on LAN feature has not been disabled through the management module, the Wake on LAN feature can turn on the blade server.



---

## Turning off the blade server

Use this information to turn off the blade server.

When you turn off the blade server, it is still connected to power through the BladeCenter unit. The blade server can respond to requests from the service processor, such as a remote request to turn on the blade server. To remove all power from the blade server, you must remove it from the BladeCenter unit. Shut down the operating system before you turn off the blade server. See the operating-system documentation for information about shutting down the operating system.

The blade server can be turned off in any of the following ways:

- You can press the power button on the blade server (see “Blade server controls and LEDs” on page 3). This starts an orderly shutdown of the operating system, if this feature is supported by the operating system.
- If the operating system stops functioning, you can press and hold the power button for more than 4 seconds to turn off the blade server.
- The management module can turn off the blade server through the Advanced-Management-Module web interface. For additional information, see the *IBM BladeCenter Management Module User's Guide* or go to <http://www.ibm.com/systems/management/> for more information.

---

## Blade server system-board layouts

Use this information to locate connectors, LEDs, and switches on the system board.

The following illustrations show the connectors, LEDs, and switches on the system board. The illustrations in this document might differ slightly from your hardware.

### Blade server connectors

Use this information to locate blade server system-board components and connectors for optional devices.

The following illustration shows the system-board components, including connectors for user-installable optional devices, in the blade server.

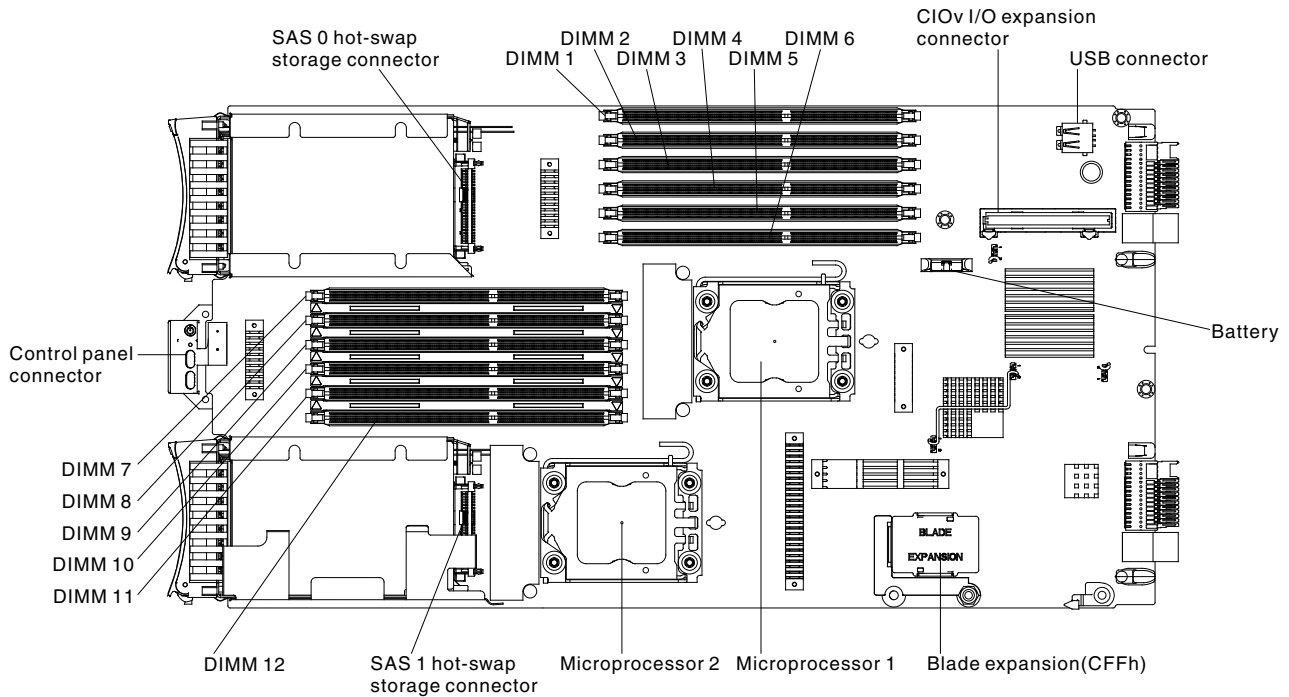

## System-board switch

Use this information to locate and define system-board switch in the blade server.

The following illustration shows the location of the light path diagnostics switch on the system board.

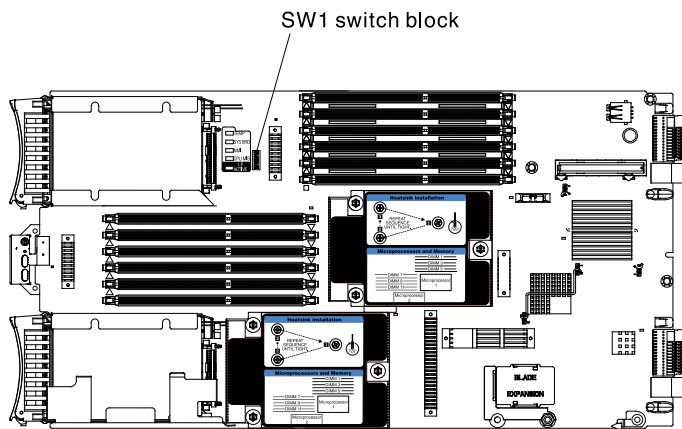

The following table describes the function of each switch in the switch block.

Switch number	Description	Switch setting	Definition
SW1 - 1	Password override switch	Changing position of this switch resets the power on password.	This switch overrides the power on password. The system ships with this switch off, but it can be on or off in a functioning system.
SW1 - 2	Trusted Platform Module (TPM) physical presence	The default position is off.	Turning this switch to the on position indicates a physical presence to the TPM.
SW1 - 3	PCH RTC reset	Normally open. Toggle to reset RTC.	Resets the RTC. A momentary toggle is all that is required. To avoid excessive battery drain, do not leave this switch closed.
SW1 - 4	Boot using the backup IMM code	The default position is off, allowing the blade server to boot from the primary IMM firmware.	When the switch is in the default off position, the blade server will boot using the primary IMM firmware. When the switch is on, the blade server will boot using a backup of the IMM firmware.
SW1 - 5	Boot backup UEFI	The default position is off, allowing the blade server to boot from the primary UEFI firmware.	When the switch is on it allows the blade server to boot using the backup UEFI.
SW1 - 6	Boot IMM recovery partition	Normally open. Toggle to boot from the IMM recovery partition.	Reserved.
SW1 - 7	IMM TPM physical presence	The default position is off.	Turning this switch to the on position indicates a physical presence to the IMM TPM.
SW1 - 8	Force RTMM update	The default position is off.	Reserved.

## System-board LEDs

Use this information to locate system-board LEDs in the blade server.

You must remove the blade server from the BladeCenter unit, open the cover or remove any optional expansion units, and press the power button (see “Blade server controls and LEDs” on page 3) to light any error LEDs that were turned on during processing. Diagnosing problems using the light path diagnostic LEDs is described in “Light path diagnostics” on page 164.

The following illustration shows the LEDs on the system board.

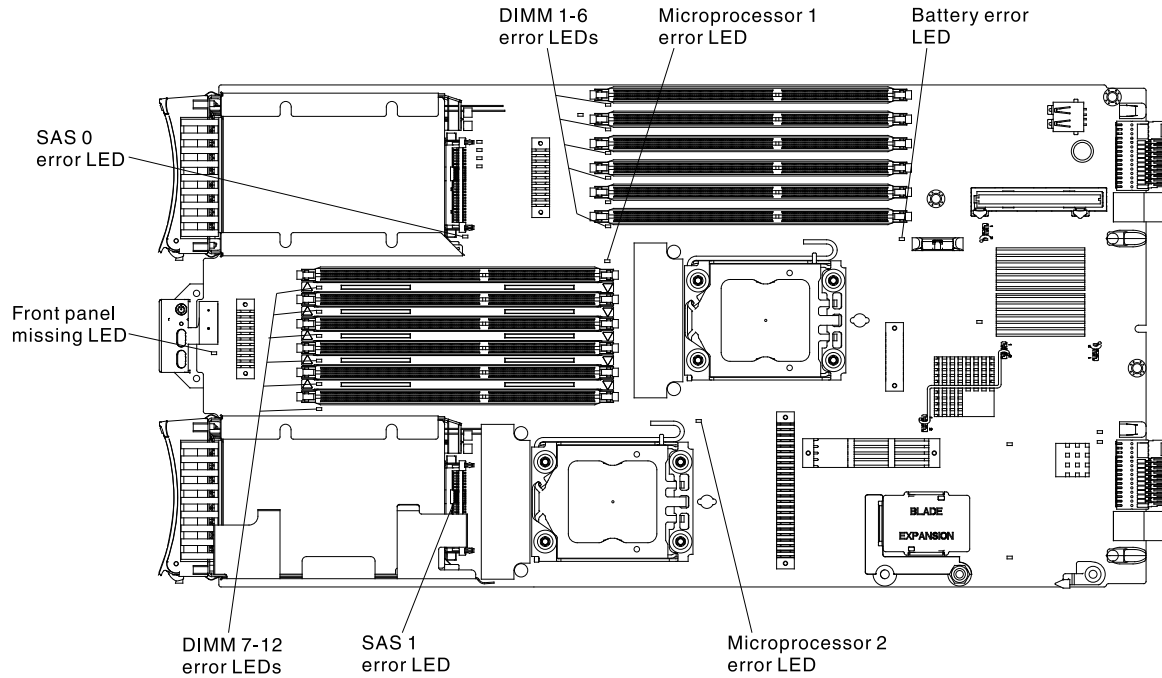

The following illustration shows the light path diagnostics panel on the system board.

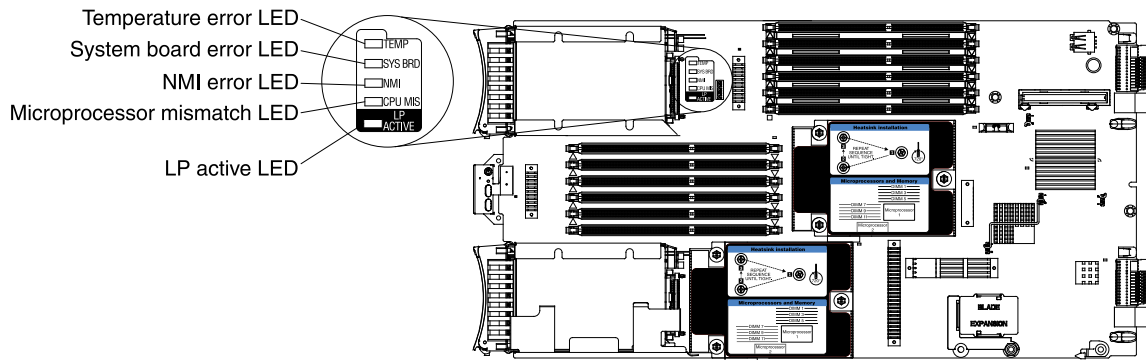

---

## Chapter 2. Configuring the blade server

Use this information for details about the configuration requirements of the blade server.

This chapter describes the configuration requirements of the blade server. Before you continue, make sure that the blade server has the latest version of firmware code. For additional information, see “Updating firmware and device drivers” on page 23.

The following configuration programs come with the blade server:

- **Setup utility**

The Setup utility is used to change system settings, such as date and time, and password. See “Using the Setup utility” on page 11 for more information.

- **LSI Logic Configuration Utility program**

The LSI Logic Configuration Utility program is stored in the blade-server firmware. Use it to set the device scan order and to set the storage drive controller IDs. See “Creating an array using the ServeRAID H1135 configuration utility” on page 25 for more information.

- **IBM FastSetup**

IBM FastSetup is a no-cost software tool that helps simplify the maintenance and deployment of selected IBM BladeCenter chassis, servers, and components. The intuitive graphical interface initializes all phases of server setup, including discovery, update, and configuration. Features include templates that enable replication of settings to many servers and automation that reduces hands-on time and user errors. Wizards and other default settings enable customization capabilities. The low-touch, set-once and walk-away feature reduces the hands-on server setup time from days to minutes, particularly for larger deployments. For information about this tool, see <http://www.ibm.com/support/entry/portal/docdisplay?Indocid=TOOL-FASTSET>.

- **IBM ServerGuide Setup and Installation CD**

The ServerGuide program provides software-setup tools and installation tools that are designed for the blade server. Use this CD during the installation of the blade server to configure basic hardware features and to simplify the installation of the operating system. For information about obtaining and using this CD, see “Using the ServerGuide Setup and Installation CD” on page 21.

- **Preboot Execution Environment (PXE) boot agent utility program**

The PXE boot agent utility program is part of the blade server firmware. Use it to select the boot protocol and other boot options and to select a power-management option. For information about using this utility program, see “Setting the PXE boot protocol using the Setup utility” on page 23.

The IBM Remote Deployment Manager (RDM) Version 4.4 program is available for purchase. You can use RDM to install a UEFI code update onto a blade server. For the latest information about RDM, including which operating systems that RDM supports and how to purchase the software, see <http://www.ibm.com/systems/management/>.

---

### Using the Setup utility

Use these instructions to start the Setup utility.

To start the Setup utility, complete the following steps:

Step 1. Turn on the blade server (see “Turning on the blade server” on page 6).

- Step 2. Immediately give the blade server control of the BladeCenter unit shared keyboard, video, and mouse ports.
- If you are managing the blade server by using the BladeCenter system console, press the KVM select button on the blade server (see “Blade server controls and LEDs” on page 3 for information).
  - If you are managing the blade server from a remote location, see the *IBMBladeCenter Management Module User's Guide*, *IBMBladeCenter Management Module Command-Line Interface Reference Guide*, or *IBMBladeCenter Serial over LAN Setup Guide* for information and instructions.
- Step 3. When the prompt <F1> Setup is displayed, press F1. If you have set an administrator password, you must type the administrator password to access the full Setup-utility menu. If you do not type the administrator password, a limited Setup-utility menu is available.
- Step 4. Follow the instructions on the screen.

## Setup utility menu

Use the Setup utility main menu to view and configure blade server configuration data and settings.

The following menu items are on the Setup utility main menu. Depending on the version of the Unified Extensible Firmware Interface (UEFI), some menu items might differ slightly from these descriptions.

- **System Information**

Select this choice to view information about the server. When you make changes through other choices in the Setup utility, some of those changes are reflected in the system information; you cannot change settings directly in the system information. This choice is on the full Setup utility menu only.

- **System Summary**

Select this choice to view configuration information, including the ID, speed, and cache size of the microprocessors, machine type and model of the server, the serial number, the system UUID, and the amount of installed memory. When you make configuration changes through other options in the Setup utility, the changes are reflected in the system summary; you cannot change settings directly in the system summary.

- **Product Data**

Select this choice to view the system-board identifier, the revision level or issue date of the firmware, the integrated management module and diagnostics code, and the version and date.

This choice is on the full UEFI Setup Utility menu only.

- **System Settings**

Select this choice to view or change the server component settings.

- **Adapters and UEFI Drivers**

Select this choice to view information about the UEFI 2.0 (and prior) adapters and UEFI drivers installed in the blade server.

**Note:** Before you configure a UEFI-compatible device, you should update the firmware for your blade server. See “Updating firmware and device drivers” on page 23 for information about how to update the firmware for your blade server.

To configure a UEFI-compatible expansion adapter, complete the following steps:

1. Select **Please refresh this page first** and press Enter.
2. Select the device driver that you want to configure and press Enter.
3. When you have finished changing settings, press Esc to exit from the program; select **Save** to save the settings that you have changed.

- **Processors**  
Select this choice to view or change the processor settings.
- **Memory**  
Select this choice to view or change the memory settings.
- **Devices and I/O Ports**  
Select this choice to view or change assignments for devices and input/output (I/O) ports. You can configure the remote console redirection, and enable or disable integrated Ethernet controllers. If you disable a device, it cannot be configured, and the operating system cannot detect it (disabling a device is equivalent to disconnecting the device).  
You can also choose to enable or disable adapter option ROM support. Disabling support can potentially improve the time it takes the blade server to start.  
  
**Note:** When you disable Ethernet 1 controller in the Setup utility, both the Ethernet 1 and Ethernet 2 controllers are disabled. However, if you disable Ethernet 2 controller in the Setup utility, only the Ethernet 2 controller is disabled.
- **Power**  
Select this choice to view or change Active Energy Manager (AEM) power capping to control power consumption and processor performance states.
- **Operating Modes**  
Select this choice to determine operational settings, such as operating mode (acoustic, efficiency, or performance) and memory speed.
- **Legacy Support** Select this choice to view or set legacy support.
  - **Force Legacy Video on Boot**  
Select this choice to enable or disable force INT video support, if the operating system does not support UEFI video output standards. The default is **Enable**.
  - **Rehook INT 19h**  
Select this choice to enable or disable devices from taking control of the boot process. The default is **Disable**.
  - **Legacy Thunk Support**  
Select this choice to enable or disable UEFI to interact with PCI mass storage devices that are non-UEFI compliant. The default is **Enable**.
  - **Infinite Boot Retry**  
Select this choice to enable or disable UEFI to infinitely retry the legacy boot order. The default is **Disable**.
  - **BBS Boot**  
Select this choice to enable or disable legacy boot in BBS manner. The default is **Enable**.
  - **Non-Planar PXE**  
Select this choice to enable or disable non-planar PXE for legacy mode. The default is **Enable**.
- **System Security**  
Select this choice to view or change the security options for Trusted Platform Module (TPM).
- **Integrated Management Module**  
Select this choice to view or change the settings for the integrated management module II (IMM2).
  - **Commands on USB Interface Preference**  
Select this choice to specify whether the Ethernet over USB interface is enabled or disabled.

**Notes:** This option is primarily for older operating systems that have problems with USB communications device class (CDC) Ethernet interfaces. Disabling this option will cause the following issues:

- Online update packages will not work.
- Updates that use Bootable Media Creator (BoMC) will not work because BoMC uses the LAN over USB interface.
- You must install the IPMI device driver to use ASU to change the IMM2 or UEFI configuration.
- You cannot set the IMM2 OS Loader watchdog.

– **Network Configuration**

Select this choice to view the system management network interface port, the IMM2 MAC address, the current IMM2 IP address, and host name.

– **Restore IMM to Defaults**

Select this choice to restore the IMM2 to the default settings. The IMM2 controller restarts after you restore the settings.

– **Restart IMM**

Select this choice to restart the IMM2 controller.

– **Recovery**

Select this choice to view or change the system recovery parameters.

– **POST Attempts**

Select this choice to view or change the number of attempts to POST.

- **POST Attempts Limit**

Select this choice to view or change the Nx boot failure parameters.

– **System Recovery**

Select this choice to view or change system recovery settings.

- **POST Watchdog Timer**

Select this choice to view or enable the POST watchdog timer.

- **POST Watchdog Timer Value**

Select this choice to view or set the POST loader watchdog timer value in minutes.

- **Reboot System on NMI**

Select this choice to enable or disable restarting the system whenever a nonmaskable interrupt (NMI) occurs. **Enable** is the default.

- **Halt on Severe Error**

Select this choice to enable or disable the system from booting into OS, displaying the POST event viewer whenever a severe error was detected. **Disable** is the default.

– **Storage**

Select this choice to view or change the storage device settings.

– **Network**

Select this choice to view or change the network device options, such as iSCSI.

– **Drive Health**

Select this choice to view the status of the controllers installed in the blade server.

- **Date and Time**

Select this choice to set the date and time in the server, in 24-hour format (*hour:minute:second*).



This choice is on the full UEFI Setup Utility menu only.

- **Start Options**

Select this choice to view or change the start options, including the startup sequence, keyboard NumLock state, PXE boot option, and PCI device boot priority. Changes in the startup options take effect when you start the server.

The startup sequence specifies the order in which the server checks devices to find a boot record. The server starts from the first boot record that it finds. If the server has Wake on LAN hardware and software and the operating system supports Wake on LAN functions, you can specify a startup sequence for the Wake on LAN functions. For example, you can define a startup sequence that checks for a disc in the CD-RW/DVD drive, then checks the hard disk drive, and then checks a network adapter.

This choice is on the full UEFI Setup Utility menu only.

- **Boot Manager**

Select this choice to view, add, delete, or change the device boot priority, boot from a file, select a one-time boot, or reset the boot order to the default setting.

- **System Event Logs**

Select this choice to access the System Event Manager, where you can view the POST event log and the system-event log.

The POST event log contains the three most recent error codes and messages that were generated during POST.

The system-event log contains POST and system management interrupt (SMI) events and all events that are generated by the baseboard management controller that is embedded in the integrated management module.

**Important:** If the system-error LED on the front of the blade server is lit but there are no other error indications, clear the system-event log. Also, after you complete a repair or correct an error, clear the system-event log to turn off the system-error LED on the front of the blade server.

- **POST Event Viewer**

- Select this choice to enter the POST event viewer to view the UEFI diagnostic codes.

- **System Event Log**

- Select this choice to view the system-event log.

- **Clear System Event Log**

- Select this choice to clear the system-event log.

- **User Security**

Select this choice to set, change, or clear passwords. See “Using passwords” on page 16 for more information.

- **Save Settings**

Select this choice to save the changes that you have made in the settings.

- **Restore Settings**

Select this choice to cancel the changes that you have made in the settings and restore the previous settings.

- **Load Default Settings**

Select this choice to cancel the changes that you have made in the settings and restore the factory settings.

- **Exit Setup**

Select this choice to exit from the Setup utility. If you have not saved the changes that you have made in the settings, you are asked whether you want to save the changes or exit without saving them.

## Using passwords

Use this information to set, change, or delete a power-on password.

You can set, change, and delete a power-on password and an administrator password in the Setup utility by selecting **System Settings** then **System Security**.

If you set a power-on password, you must type the power-on password to complete the system startup and to have access to the Setup Utility menu.

The password must be from 6 to 20 characters. You can use any combination of ASCII printable characters for the password. Keep a record of your password in a secure place.

If you forget the power-on password, you can regain access to the blade server either by removing the blade server battery and then reinstalling it or by using the power-on password override switch (see “Removing the battery” on page 51 and “Installing the battery” on page 51).

An administrator password is intended to be used by a system administrator; it limits access to the full Setup utility menu.

**Attention:** If you set an administrator password and then forget it, there is no way to change, override, or remove it. You must replace the system board.

## Using the Boot Menu program

Use the Boot Menu program to temporarily redefine the first startup device without changing settings in the Setup utility.

The Boot Menu program is a built-in, menu-driven configuration utility program that you can use to temporarily redefine the first startup device without changing settings in the Setup utility.

To use the Boot Menu program, complete the following steps:

- Step 1. Turn off the server.
- Step 2. Restart the server.
- Step 3. When the prompt <F12> Select Boot Device is displayed, press F12 . If a bootable USB mass storage device is installed, a submenu item (**USB Key/Disk**) is displayed.
- Step 4. Use the Up arrow and Down arrow keys to select an item from the **Boot Selection Menu** and press Enter.

The next time the server starts, it returns to the startup sequence that is set in the Setup utility.

## Updating the Universal Unique Identifier (UUID)

The Universal Unique Identifier (UUID) must be updated when the system board is replaced.

Use the Advanced Settings Utility to update the UUID in the UEFI-based server. The ASU is an online tool that supports several operating systems. Make sure that you download the version for your operating system. You can download the ASU from the IBM website. To download the ASU and update the UUID, complete the following steps.

- Step 1. Download the Advanced Settings Utility (ASU) from <http://www.ibm.com/support/entry/portal/docdisplay?Indocid=TOOL-ASU>.
- Step 2. Select one of the following methods to access the Integrated Management Module (IMM) to set the UUID:

- Online from the target system (LAN or keyboard console style (KCS) access)
- Remote access to the target system (LAN based)
- Bootable media containing ASU (LAN or KCS, depending upon the bootable media)

**Note:** IBM provides a method for building a bootable media. You can create a bootable media using the Bootable Media Creator (BoMC) application from <http://www.ibm.com/support/entry/portal/docdisplay?lnocid=TOOL-BOMC>. In addition, the Windows and Linux based tool kits are also available to build a bootable media.

Step 3. Copy and unpack the ASU package, which also includes other required files, to the server. Make sure that you unpack the ASU and the required files to the same directory. In addition to the application executable (asu or asu64), the following files are required:

- For Windows based operating systems:
  - ibm\_rndis\_server\_os.inf
  - device.cat
- For Linux based operating systems:
  - cdc\_interface.sh

Step 4. After you install ASU, use the following command syntax to set the UUID:

```
asu set SYSTEM_PROD_DATA.SysInfoUUID <uuid_value> [access_method]
```

Where:

*<uuid\_value>*

Up to 16-byte hexadecimal value assigned by you.

*[access\_method]*

The access method that you selected to use from the following methods:

- Online authenticated LAN access, type the command:

```
[host <imm_internal_ip>] [user <imm_user_id>][password <imm_password>]
```

Where:

*imm\_internal\_ip*

The IMM internal LAN/USB IP address. The default value is 169.254.95.118.

*imm\_user\_id*

The IMM account (1 of 12 accounts). The default value is USERID.

*imm\_password*

The IMM account password (1 of 12 accounts). The default value is PASSWORD (with a zero 0 not an O).

**Note:** If you do not specify any of these parameters, ASU will use the default values. When the default values are used and ASU is unable to access the IMM using the online authenticated LAN access method, ASU will automatically use the unauthenticated KCS access method.

The following commands are examples of using the userid and password default values and not using the default values:

Example that does not use the userid and password default values:

```
asu set SYSTEM_PROD_DATA.SysInfoUUID <uuid_value> user <user_id>
password <password>
```

Example that does use the userid and password default values:

```
asu set SYSTEM_PROD_DATA.SysInfoUUID <uuid_value>
```

- Online KCS access (unauthenticated and user restricted):

You do not need to specify a value for *access\_method* when you use this access method.

Example:

```
asu set SYSTEM_PROD_DATA.SysInfoUUID <uuid_value>
```

The KCS access method uses the IPMI/KCS interface. This method requires that the IPMI driver be installed. Some operating systems have the IPMI driver installed by default. ASU provides the corresponding mapping layer. See the *Advanced Settings Utility Users Guide* for more details. You can access the ASU Users Guide from <http://www.ibm.com/support/entry/portal/docdisplay?Indocid=TOOL-ASU>.

- Remote LAN access, type the command:

**Note:** When using the remote LAN access method to access IMM using the LAN from a client, the *host* and the *imm\_external\_ip* address are required parameters.

```
host <imm_external_ip> [user <imm_user_id>[[password <imm_password>]
```

Where:

*imm\_external\_ip*

The external IMM LAN IP address. There is no default value. This parameter is required.

*imm\_user\_id*

The IMM account (1 of 12 accounts). The default value is USERID.

*imm\_password*

The IMM account password (1 of 12 accounts). The default value is PASSWORD (with a zero 0 not an O).

The following commands are examples of using the userid and password default values and not using the default values:

Example that does not use the userid and password default values:

```
asu set SYSTEM_PROD_DATA.SysInfoUUID <uuid_value> host <imm_ip>
user <user_id> password <password>
```

Example that does use the userid and password default values:

```
asu set SYSTEM_PROD_DATA.SysInfoUUID <uuid_value> host <imm_ip>
```

- Bootable media:

You can also build a bootable media using the applications available at <http://www.ibm.com/support/entry/portal/docdisplay?Indocid=TOOL-BOMC>.

Step 5. Restart the server.

## Updating the DMI/SMBIOS data

The Desktop Management Interface (DMI) must be updated when the system board is replaced.

Use the Advanced Settings Utility to update the DMI in the UEFI-based server. The ASU is an online tool that supports several operating systems. Make sure that you download the version for your operating system. You can download the ASU from the IBM website. To download the ASU and update the DMI, complete the following steps.

Step 1. Download the Advanced Settings Utility (ASU) from

<http://www.ibm.com/support/entry/portal/docdisplay?Indocid=TOOL-ASU>.

Step 2. ASU sets the DMI in the Integrated Management Module (IMM). Select one of the following methods to access the IMM to set the DMI:

- Online from the target system (LAN or keyboard console style (KCS) access)
- Remote access to the target system (LAN based)

- Bootable media containing ASU (LAN or KCS, depending upon the bootable media)

**Note:** IBM provides a method for building a bootable media. You can create a bootable media using the Bootable Media Creator (BoMC) application from <http://www.ibm.com/support/entry/portal/docdisplay?Indocid=TOOL-BOMC>. In addition, the Windows and Linux based tool kits are also available to build a bootable media.

Step 3. Copy and unpack the ASU package, which also includes other required files, to the server. Make sure that you unpack the ASU and the required files to the same directory. In addition to the application executable (asu or asu64), the following files are required:

- For Windows based operating systems:
  - ibm\_rndis\_server\_os.inf
  - device.cat
- For Linux based operating systems:
  - cdc\_interface.sh

Step 4. After you install ASU, type the following commands to set the DMI:

```
asu set SYSTEM_PROD_DATA.SysInfoProdName <tm/t_model> [access_method]
```

```
asu set SYSTEM_PROD_DATA.SysInfoSerialNum <s/n> [access_method]
```

```
asu set SYSTEM_PROD_DATA.SysEncloseAssetTag <asset_tag> [access_method]
```

Where:

*<m/t\_model>*

The server machine type and model number. Type *mtm xxxxyyy*, where *xxxx* is the machine type and *yyy* is the server model number.

*<s/n>*

The serial number on the server. Type *sn zzzzzzz*, where *zzzzzzz* is the serial number.

*<asset\_method>*

The server asset tag number. Type *asset aaaaaaaaaaaaaaaaaaaaaaaaaaaaaa*, where *aaaaaaaaaaaaaaaaaaaaaaaaaaaaaaaa* is the asset tag number.

*[access\_method]*

The access method that you select to use from the following methods:

- Online authenticated LAN access, type the command:

```
[host <imm_internal_ip>] [user <imm_user_id>][password <imm_password>]
```

Where:

*imm\_internal\_ip*

The IMM internal LAN/USB IP address. The default value is 169.254.95.118.

*imm\_user\_id*

The IMM account (1 of 12 accounts). The default value is USERID.

*imm\_password*

The IMM account password (1 of 12 accounts). The default value is PASSWORD (with a zero 0 not an O).

**Note:** If you do not specify any of these parameters, ASU will use the default values. When the default values are used and ASU is unable to access the IMM using the online authenticated LAN access method, ASU will automatically use the following unauthenticated KCS access method.

The following commands are examples of using the userid and password default values and not using the default values:

Examples that do not use the userid and password default values:

```
asu set SYSTEM_PROD_DATA.SysInfoProdName <m/t_model> -user <imm_user_id> -password <imm_password>
```

```
asu set SYSTEM_PROD_DATA.SysInfoSerialNum <s/n> -user <imm_user_id> -password <imm_password>
```

```
asu set SYSTEM_PROD_DATA.SysEncloseAssetTag <asset_tag> -user <imm_user_id> -password <imm_password>
```

Examples that do use the userid and password default values:

```
asu set SYSTEM_PROD_DATA.SysInfoProdName <m/t_model>
```

```
asu set SYSTEM_PROD_DATA.SysInfoSerialNum <s/n>
```

```
asu set SYSTEM_PROD_DATA.SysEncloseAssetTag <asset_tag>
```

- Online KCS access (unauthenticated and user restricted): You do not need to specify a value for *access\_method* when you use this access method.

The KCS access method uses the IPMI/KCS interface. This method requires that the IPMI driver be installed. Some operating systems have the IPMI driver installed by default. ASU provides the corresponding mapping layer. See the *Advanced Settings Utility Users Guide* at <http://www.ibm.com/support/entry/portal/docdisplay?Indocid=TOOL-ASU> for more details.

The following commands are examples of using the userid and password default values and not using the default values:

Examples that do not use the userid and password default values:

```
asu set SYSTEM_PROD_DATA.SysInfoProdName &lt;m/t_model>
```

```
asu set SYSTEM_PROD_DATA.SysInfoSerialNum &lt;s/n>
```

```
asu set SYSTEM_PROD_DATA.SysEncloseAssetTag &lt;asset_tag>
```

- Remote LAN access, type the command:

**Note:** When using the remote LAN access method to access IMM using the LAN from a client, the *host* and the *imm\_external\_ip* address are required parameters.

```
host <imm_external_ip> [user <imm_user_id>][password <imm_password>]
```

Where:

*imm\_external\_ip*

The external IMM LAN IP address. There is no default value. This parameter is required.

*imm\_user\_id*

The IMM account (1 of 12 accounts). The default value is USERID.

*imm\_password*

The IMM account password (1 of 12 accounts). The default value is PASSWORD (with a zero 0 not an O).

The following commands are examples of using the userid and password default values and not using the default values:

Examples that do not use the userid and password default values:

```
asu set SYSTEM_PROD_DATA.SysInfoProdName <m/t_model> -host <imm_ip> -user <imm_user_id> -password <imm_password>
```

```
asu set SYSTEM_PROD_DATA.SysInfoSerialNum <s/n> -host <imm_ip> -user <imm_user_id> -password <imm_password>
```

```
asu set SYSTEM_PROD_DATA.SysEncloseAssetTag <asset_tag> -host <imm_ip> -user  
<imm_user_id> -password <imm_password>
```

Examples that do use the userid and password default values:

```
asu set SYSTEM_PROD_DATA.SysInfoProdName <m/t_model> -host <imm_ip>
```

```
asu set SYSTEM_PROD_DATA.SysInfoSerialNum <s/n> -host <imm_ip>
```

```
asu set SYSTEM_PROD_DATA.SysEncloseAssetTag <asset_tag> -host <imm_ip>
```

- Bootable media:

You can also build a bootable media using the applications available at <http://www.ibm.com/support/entry/portal/docdisplay?Indocid=TOOL-BOMC>.

Step 5. Restart the server.

---

## Using the ServerGuide Setup and Installation CD

Use this information as an overview for using the ServerGuide Setup and Installation CD.

The *ServerGuide Setup and Installation* CD contains a setup and installation program that is designed for your blade server. The ServerGuide program detects the blade server model and optional hardware devices that are installed and uses that information during setup to configure the hardware. The ServerGuide program simplifies operating-system installations by providing updated device drivers and, in some cases, installing them automatically.

You can download a free image of the *ServerGuide Setup and Installation* CD or purchase the CD from the ServerGuide fulfillment website at <http://www.ibm.com/support/entry/portal/docdisplay?Indocid=SERV-GUIDE>. To download the free image, click **IBM Service and Support Site**.

**Note:** Changes are made periodically to the IBM website. The actual procedure might vary slightly from what is in this document.

The ServerGuide program performs the following tasks:

- An easy-to-use interface
- Diskette-free setup and configuration programs that are based on detected hardware
- Device drivers that are provided for the blade server model and detected hardware
- Operating-system partition size and file-system type that are selectable during setup

## ServerGuide features

Use this information to determine the ServerGuide features.

Features and functions can vary slightly with different versions of the ServerGuide program. To learn more about the version that you have, start the *ServerGuide Setup and Installation* CD and view the online overview. Not all features are supported on all blade server models.

The ServerGuide program requires a supported IBM blade server that is associated with an enabled startable (bootable) CD drive. In addition to the *ServerGuide Setup and Installation* CD, you must have the operating-system CD to install the operating system.

The ServerGuide program has the following features:

- Sets system date and time

- Detects installed optional hardware devices and provides updated device drivers for most adapters and devices
- Provides diskette-free installation for supported Windows operating systems
- Includes an online readme file with links to tips for the hardware and operating-system installation

## Setup and configuration overview

Use this information to setup and configure the blade server.

When you use the *ServerGuide Setup and Installation* CD, you do not need setup diskettes. You can use the CD to configure any supported IBM blade server model. The setup program provides a list of tasks that are required to set up the blade server.

**Note:** Features and functions can vary slightly with different versions of the ServerGuide program.

When you start the *ServerGuide Setup and Installation* CD, the program prompts you to complete the following tasks:

- Select your language.
- Select your keyboard layout and country.
- View the overview to learn about ServerGuide features.
- View the readme file to review installation tips for your operating system and adapter.
- Start the operating-system installation. You will need your operating-system CD.

## Installing the operating system

Use these instructions to install the operating system on the blade server.

To install the operating system on a blade server, you can use any of the following methods:

- Use the *ServerGuide Setup and Installation* CD to install a supported Microsoft Windows operating system.
- Use Remote Deployment Manager (RDM) Version 4.20 (or later) to install a supported operating system. To determine whether RDM supports an operating system, see <http://www.ibm.com/systems/management/>.
- Download the latest operating-system installation instructions and install the operating system.

**Important:** The operating system in the blade server must provide USB support for the blade server to recognize and use the keyboard, mouse, and removable-media drives. The BladeCenter unit uses USB for internal communication with these devices.

## Typical operating-system installation

Use this information for a typical ServerGuide operating-system installation.

The ServerGuide program can reduce the time it takes to install an operating system. It provides the device drivers that are required for the hardware and for the operating system that you are installing. This section describes a typical ServerGuide operating-system installation.

**Note:** Features and functions can vary slightly with different versions of the ServerGuide program.

1. After you have completed the setup process, the operating-system installation program starts. (You will need your operating-system CD to complete the installation.)
2. The ServerGuide program stores information about the blade server model, service processor, hard disk drive controllers, and network adapters. Then, the program checks the CD for newer device drivers. This information is stored and then passed to the operating-system installation program.



3. The ServerGuide program presents operating-system partition options that are based on your operating-system selection and the installed hard disk drives.
4. The ServerGuide program prompts you to insert your operating-system CD and restart the blade server. At this point, the installation program for the operating system takes control to complete the installation. The BladeCenter CD drive must be associated with the blade server when this step is performed.

## Installing the operating system without using ServerGuide

Use these instructions to install the operating system on the blade server without using a ServerGuide.

If you have already configured the blade server hardware and you are not using the ServerGuide program to install the operating system, download the latest operating-system installation instructions from the IBM website at <http://www.ibm.com/supportportal/>.

---

## Setting the PXE boot protocol using the Setup utility

Use the Setup utility to set the PXE boot protocol.

To use the Setup utility to configure the boot protocol to boot from a non-UEFI legacy network device for all PXE boot attempts, complete the following steps:

1. Turn on the server (see “Turning on the blade server” on page 6).
2. When the prompt Press <F1> Setup is displayed, press F1. If you have set an administrator password, you must type the administrator password to access the full Setup utility menu. If you do not type the administrator password, a limited Setup utility menu is available.
3. From the Setup utility main menu, select **Boot Manager**.
4. Select **Boot Modes**; then select **Legacy Only**.
5. Press Esc twice to return to the Setup utility main menu.
6. Select **Save Settings** and then select **Exit Setup**.

To use the Setup utility to configure the boot protocol to boot from a non-UEFI legacy network device for the next boot only, complete the following steps:

1. Turn on the server (see “Turning on the blade server” on page 6).
2. When the prompt Press <F1> Setup is displayed, press F1. If you have set an administrator password, you must type the administrator password to access the full Setup utility menu. If you do not type the administrator password, a limited Setup utility menu is available.
3. From the Setup utility main menu, select **Boot Manager**.
4. Select **Add Boot Option**; then select **Generic Boot Option**.
5. Select **Legacy Only**.
6. Press Esc three times to return to the Setup utility main menu.
7. Select **Save Settings** and then select **Exit Setup**.

**Note:** Press Ctrl+P when prompted during POST to access the PXE boot agent utility program.

---

## Updating firmware and device drivers

IBM periodically makes UEFI code, service processor (IMM) firmware, diagnostic firmware updates, and device driver updates available for the blade server. Provisioning is the set of actions you take to update the firmware and device drivers, and install the operating system. Several tools are available to help update the firmware and device drivers in the provisioning process. Use the instructions that are included with the downloaded files.

**Attention:**

1. Some cluster solutions require specific code levels or coordinated code updates. If the device is part of a cluster solution, verify that the latest level of code is supported for the cluster solution before you update the code.
2. Before you update the firmware, be sure to back up any data that is stored in the Trusted Platform Module (TPM), in case any of the TPM characteristics are changed by the new firmware. For instructions, see your encryption software documentation.
3. Installing the wrong firmware or device-driver update might cause the blade server to malfunction. Before you install a firmware or device-driver update, read any readme and change history files that are provided with the downloaded update. These files contain important information about the update and the procedure for installing the update, including any special procedure for updating from an early firmware or device-driver version to the latest version.

**• UpdateXpress System Packs**

UpdateXpress System Packs (UXSP) contain an integration-tested bundle of online, updateable firmware and device drivers for your blade server. The IBM ToolsCenter Bootable Media Creator uses UpdateXpress System Packs to update the firmware and device drivers.

Typically, use UpdateXpress System Packs to update firmware and devices drivers for a blade server that has previously been provisioned. For more information about UpdateXpress System Packs, see <http://www.ibm.com/support/entry/portal/docdisplay?Indocid=TOOL-ASU>.

**• IBM ToolsCenter Bootable Media Creator**

You can use IBM ToolsCenter Bootable Media Creator to create bootable media that is suitable for applying firmware updates, and running preboot diagnostics. Using IBM ToolsCenter Bootable Media Creator, you can create a single bootable image on supported media (such as CD, DVD, ISO image, USB flash drive, or set of PXE files) that bundles multiple IBM BladeCenter system tools and updates from UpdateXpress System Packs, which contain Windows and Linux® firmware updates.

Typically, use IBM ToolsCenter Bootable Media Creator for the initial set up of a blade server. For more information about the IBM Bootable Media Creator, see <http://www.ibm.com/support/entry/portal/docdisplay?Indocid=TOOL-BOMC>.

**Important:** To avoid problems and to maintain system performance, always make sure that the UEFI code, service processor (IMM) firmware, and diagnostic firmware levels are consistent for all blade servers within the BladeCenter unit.

---

## Configuring UEFI compatible devices

Use this information to configure UEFI compatible devices.

Your IBM BladeCenter HS23E Type 8038 or 8039 blade server is UEFI compatible. UEFI compatible expansion cards can be configured through the Setup utility. To configure a UEFI compatible expansion card, complete the following steps:

**Note:** Before configuring a UEFI compatible device, it is recommended to update the firmware for your blade server. See “Updating firmware and device drivers” on page 23 for information on how to update the firmware for your blade server.

1. Run the Setup utility (see “Using the Setup utility” on page 11).
2. Select **System Settings** ® **Network** or **Storage** depending on the type of your adapters.

**Note:** Select **System Settings** ® **Adapters and UEFI drivers** for UEFI 2.0 (and prior) compliant adapters and drivers installed in the server.

3. Select **Please refresh this page first** and press Enter.

4. Select the device driver that you want to configure and press Enter.
5. When you have finished changing settings, press Esc to exit from the program; select **Save** to save the settings that you have changed.

---

## Configuring the Gigabit Ethernet controller

Use this information to locate the device drivers for the Gigabit Ethernet controller.

One dual-port Gigabit Ethernet controller is integrated on the blade server system board. The controller provides a 1000 Mbps full-duplex interface for connecting to one of the Ethernet-compatible I/O modules in I/O-module bays 1 and 2, which enables simultaneous transmission and reception of data on the Ethernet local area network (LAN). The Ethernet controller on the system board is routed to I/O-module bay 1 or bay 2. The logical link of each Ethernet port to an I/O-module bay is assigned by the operating system.

You do not have to set any jumpers or configure the controller for the blade server operating system. However, you must install a device driver to enable the blade server operating system to address the Ethernet controller. For device drivers and information about configuring the Ethernet controller, go to <http://www.ibm.com/supportportal/>.

---

## Creating an array using the ServeRAID H1135 configuration utility

Use these instructions to create an array using the ServeRAID H1135 configuration utility.

Use the LSI Configuration Utility program to configure and manage redundant array of independent disks (RAID) arrays. Be sure to use this program as described in this document.

The integrated SAS/SATA controller with RAID capabilities supports RAID arrays. You can use the LSI Configuration Utility program to configure RAID 1 (IM), RAID 1E (IME), and RAID 0 (IS) for a single pair of attached devices. If you install the optional ServeRAID H1135 SAS/SATA controller, it provides RAID levels 0, 1, and, 10 support. If you install a different type of RAID adapter, follow the instructions in the documentation that comes with the adapter to view or change settings for attached devices.

In addition, you can download an LSI command-line configuration program from <http://www.ibm.com/supportportal/>.

When you are using the LSI Configuration Utility program to configure and manage arrays, consider the following information:

- The integrated SAS/SATA controller with RAID capabilities supports the following features:
  - Integrated Mirroring (IM) with hot-spare support (also known as RAID 1) Use this option to create an integrated array of two disks plus up to two optional hot spares. All data on the primary disk can be migrated.
  - Integrated Mirroring Enhanced (IME) with hot-spare support (also known as RAID 1E) Use this option to create an integrated mirror enhanced array of three to eight disks, including up to two optional hot spares. All data on the array disks will be deleted.
  - Integrated Striping (IS) (also known as RAID 0) Use this option to create an integrated striping array of two to eight disks. All data on the array disks will be deleted.
- Hard disk drive capacities affect how you create arrays. The drives in an array can have different capacities, but the RAID controller treats them as if they all have the capacity of the smallest hard disk drive.
- If you use an integrated SAS/SATA controller with RAID capabilities to configure a RAID 1 (mirrored) array after you have installed the operating system, you will lose access to any data or applications that were previously stored on the secondary drive of the mirrored pair.

- If you install a different type of RAID controller, see the documentation that comes with the controller for information about viewing and changing settings for attached devices.

## Starting the LSI Configuration Utility program

Use these instructions to start the LSI Configuration Utility program.

To start the LSI Configuration Utility program, complete the following steps:

1. Turn on the blade server, and make sure that the blade server is the owner of the keyboard, video, and mouse.
2. When the <<<Press Ctrl-C to start LSI Logic Configuration Utility>>> prompt is displayed, press Ctrl+C.
3. Use the arrow keys to select the controller from the list of adapters; then, press Enter.
4. Follow the instructions on the screen to change the settings of the selected items; then, press Enter. If you select **SAS Topology** or **Advanced Adapter Properties**, additional screens are displayed.

When you have finished changing settings, press Esc to exit from the program; select **Save** to save the settings that you have changed.

**Note:** For more information, see the *Installation and User's Guide for ServeRAID H1135* at <http://www-947.ibm.com/support/entry/portal/docdisplay?Indocid=MIGR-5088601&brandind=5000008>.

## Starting the Human Interface Infrastructure (HII) Configuration Application

Use these instructions to start the HII Configuration Application.

To start the HII Configuration Application, complete the following steps:

1. Turn on the blade server, and make sure that the blade server is the owner of the keyboard, video, and mouse.

**Note:** Approximately 20 to 40 seconds after the server is connected to power, the power-control button becomes active.

2. When the prompt <F1 Setup> is displayed, press F1. If you have set an administrator password, you are prompted to type the password.
3. Select **System Settings** ® **Storage**.
4. Under **Storage**, select the ServeRAID adapter you want to configure and press **Enter** to continue.

When you have finished changing settings, press Esc to exit from the program; select **Save** to save the settings that you have changed.

**Note:** For more information, see the *Installation and User's Guide for ServeRAID H1135* at <http://www-947.ibm.com/support/entry/portal/docdisplay?Indocid=MIGR-5088601&brandind=5000008>.

## Creating a RAID array of hard disk drives

Use this information to create a RAID array of hard disk drives.

To create a RAID array of hard disk drives, complete the following steps:

1. From the list of adapters, select the controller (channel) for the drives that you want to mirror.
2. Select **RAID Properties**.
3. Select the type of array that you want to create.

4. Use the arrow keys to highlight the first drive in the pair; then, press the Minus (-) or Plus (+) key to change the mirror value to **Primary**.
5. Continue to select the next drive using the Minus (-) or Plus (+) key until you have selected all the drives for your array.
6. Press C to create the disk array.
7. Select **Apply changes and exit menu** to create the array.

**Note:** For more information, see the *Installation and User's Guide for ServeRAID H1135* at <http://www-947.ibm.com/support/entry/portal/docdisplay?Indocid=MIGR-5088601&brandind=5000008>.

---

## Creating an array using the ServeRAID C105 configuration utility

Use these instructions to create a software RAID array of hard disk drives.

To create a software RAID array of hard disk drives, complete the following steps:

- Step 1. Turn on the blade server, and make sure that the blade server is the owner of the keyboard, video, and mouse.

**Note:** Approximately 1 to 3 minutes after the server is connected to ac power, the power-control button becomes active after the power-on LED flashes slowly.

- Step 2. When the prompt <F1 Setup> is displayed, press F1. If you have set an administrator password, you are prompted to type the password.
- Step 3. Under **System Settings**, select **Storage**.
- Step 4. Under **Storage**, select **ServeRAID C105**.
- Step 5. Under **Configuration Options**, select **Virtual Drive Management® Create Configuration**.
- Step 6. Select the type of array that you want to create.
- Step 7. Select **Select Drives** and use space key to select all the drives for your array.
- Step 8. Select **Apply Changes** to create the array.
- Step 9. When the prompt Success is displayed, select **OK** to continue.
- Step 10. After the system auto skip to the next screen, select **Save Configuration**.
- Step 11. When the prompt Creating Virtual Drives will cause the data lost on the associated Drives to be permanently deleted. is displayed, use space key to select **Yes** to continue.
- Step 12. Select **OK** to continue.
- Step 13. To initialize virtual disk, select **ServeRAID C105® Virtual Drive Management® Select Virtual Drive Operations**.
- Step 14. Under **Virtual Drive Operation**, choose **Select Operation**. Select the type of initialization you want to initialize.
- Step 15. Select **Start Operation**.
- Step 16. Select **Yes** to confirm.
- Step 17. Select **OK** to continue.
- Step 18. When the prompt Success is displayed, select **OK**.

1. For more information about ServeRAID C105, see the *User's Guide for ServeRAID C105* at <http://www-947.ibm.com/support/entry/portal/docdisplay?Indocid=MIGR-5089068&brandind=5000008>.
2. ServeRAID C105 is not supported in VMware 5 and VMware 4.1.
3. ServeRAID C105 is not supported in solid-state drives.

4. ServeRAID C105 is not supported in legacy configuration.
5. In order to install the legacy OS in the software RAID, you have to set the **SAS Controller** as the first device in the option ROM execution order and make sure that ServeRAID H1135 is not installed. See "Setting Option ROM Execution Order" on page 28 for more information.
6. ServeRAID C105 is automatically disabled when ServeRAID H1135 is installed.

## Setting Option ROM Execution Order

Use these instructions to set option ROM execution order.

To set option ROM execution order, complete the following steps:

Step 1. Turn on the blade server, and make sure that the blade server is the owner of the keyboard, video, and mouse.

**Note:** Approximately 1 to 3 minutes after the server is connected to ac power, the power-control button becomes active after the power-on LED flashes slowly.

Step 2. When the prompt <F1 Setup> is displayed, press F1. If you have set an administrator password, you are prompted to type the password.

Step 3. Under **System Settings**, select **Devices and I/O Ports**.

Step 4. Under **Devices and I/O Ports**, select **Set Option ROM Execution Order**.

Step 5. Change the order list.

Step 6. When you have finished changing settings, press Esc to exit from the program; select **Save** to save the settings that you have changed.

---

## Using LAN over USB to interface the IMM

The IMM does not require IPMI device drivers or USB daemons for in-band IMM communication. Instead, a LAN over USB interface enables in-band communications to the IMM; the IMM hardware on the system board presents an internal Ethernet NIC from the IMM to the operating system. LAN over USB is also called the "USB in-band interface" in the IMM web interface.

Typically, the IMM IP address for the LAN over USB interface is set to a static address of 169.254.95.118 with a subnet mask of 255.255.0.0. In the event of an IP address collision on the network, the IMM might obtain a different IP address in the 169.254.xxx.xxx range.

Because the IMM might obtain a random IP address for the LAN over USB interface, the IBM Advanced Settings Utility (ASU) and firmware flash utilities, DSA, and the IBM Director Agent use the Service Location Protocol (SLP) to discover the IMM IP address. These tools perform an SLP multicast discovery on the LAN over USB interface. When they receive a response from the IMM, they obtain the attributes that contain the IP address the IMM is using for the LAN over USB interface.

## Potential conflicts with the LAN over USB interface

In some situations, the IMM LAN over USB interface can conflict with certain network configurations, applications, or both.

For example, Open MPI attempts to use all of the available network interfaces on a server. Open MPI detects the IMM LAN over USB interface and attempts to use it to communicate with other systems in a clustered environment. The LAN over USB interface is an internal interface, so this interface does not work for external communications with other systems in the cluster.

## Resolving conflicts with the IMM LAN over USB interface

Use this information to resolve LAN over USB conflicts with network configurations and applications.

There are several actions that resolve LAN over USB conflicts with network configurations and applications:

1. For conflicts with Open MPI, configure the application so it does not attempt to use this interface.
2. Take the interface down (run `ifdown` under Linux).
3. Remove the driver (run `rmmmod` under Linux).
4. Disable the USB in-band interface on the IMM through either the IMM web interface or the AMM web interface.

**Important:** If you disable the USB in-band interface, you cannot perform an in-band update of the IMM firmware using the Linux or Windows flash utilities. If the USB in-band interface is disabled, use the Firmware Update option on the IMM web interface to update the firmware. If you disable the USB in-band interface, also disable the watchdog timeouts to prevent the server from restarting unexpectedly.

- Use the following steps to disable the LAN over USB interface from the IMM web interface.
  - a. Log in to the IMM on which you want to disable the USB device driver interface.
  - b. In the navigation pane, click **System Settings** and scroll down to the **Miscellaneous** area.
  - c. Select the **Do not allow commands on USB interface** check box to disable the USB in-band interface. Selecting this option does not affect the USB remote presence functions (for example, keyboard, mouse, and mass storage). When you disable the USB in-band interface, the in-band systems-management applications such as the Advanced Settings Utility (ASU) and firmware update package utilities might not work.

**Note:** The ASU works with a disabled USB in-band interface if an IPMI device driver is installed. If you try to use systems-management applications while the in-band interface is disabled, they might not work.
  - d. Click **Save**.
- Use the following steps to disable the LAN over USB interface from the AMM web interface:
  - a. Log in to the AMM web interface.
  - b. In the navigation pane, click **Blade Configuration** under the **Blade Tasks** heading.
  - c. Scroll down to the Service Processor LAN over USB interface are on the Blade Configuration web page. The section lists all blades in the chassis which are capable of enabling and disabling the LAN over USB interface.
  - d. Select the check boxes next to the blade or blades that you want to enable or disable.
  - e. Click the **Disable** button to disable the LAN over USB interface on the selected blades.

## Configuring the LAN over USB interface manually

For more information about LAN over USB configuration on different operating systems, see <http://www-947.ibm.com/support/entry/portal/docdisplay?brand=5000008&Indocid=MIGR-5083207>.

The IMM using the LAN over USB interface requires operating-system drivers and other configuration. The firmware update package or Advanced Settings Utility attempt to perform the setup automatically, if needed. If the automatic setup fails or if you prefer to set up the LAN over USB manually, use one of the following processes.

For more information about LAN over USB configuration on different operating systems, see <http://www-947.ibm.com/support/entry/portal/docdisplay?brand=5000008&Indocid=MIGR-5083207>.

## LAN over USB Windows Driver Installation

Use this information to install the LAN over USB driver for Windows.

When you install Windows, there will be an unknown RNDIS device in the device manager. IBM provides a Windows INF file that identifies this device. The signed version of the INF is included in all of the Windows versions of the IMM, UEFI, and DSA update packages. Perform the following steps to install `ibm_rndis_server_os.inf`.

**Note:** These steps only need to be performed if the server is running a Windows operating system and the `ibm_rndis_server_os.inf` file has not been previously installed. The file needs to be installed only once. It is required by Windows operating systems to detect and use the LAN over USB functionality.

1. Obtain a Windows version of the IMM, server firmware, and DSA update package (see “Updating firmware and device drivers” on page 23 for more information).
2. Extract the `ibm_rndis_server_os.inf` and `device.cat` files from the firmware update package and copy them to the `\WINDOWS\inf` subdirectory.
3. Go to **Computer Management**, then **Device Manager** and find the RNDIS Device. Select **Properties > Driver > Reinstall driver**. Point the server to the `\Windows\inf` directory where it can find the `ibm_rndis_server_os.inf` file and install the device.
4. Go to **Computer Management** then **Device Manager** and right-click on **Network adapters** and select **Scan for hardware changes**. A small pop-up confirms that the Ethernet device is found and installed. The New Hardware Wizard starts automatically.
5. When you are prompted with the question, “Can Windows connect to Windows Update to search for software?”, select **No, not this time**. Click **Next** to continue.
6. When you are prompted with the question, “What do you want the wizard to do?”, select **Install from a list or specific location (Advanced)**. Click **Next** to continue.
7. When you are prompted with the statement, “Please choose your search and installation options”, select **Don't search. I will choose the driver to install**. Click **Next** to continue.
8. When you are prompted with the statement, “Select a hardware type, and then click Next”, select **Network adapters**. Click **Next** to continue.
9. You are prompted with the statement, “Completing the Found New Hardware Wizard”. Click **Finish**.  
  
**Note:** A new local area connection appears and might state, “This connection has limited or no connectivity”. Ignore this message.
10. Go back to the Device Manager. **IBM USB Remote NDIS Network Device** appears under **Network Adapters**.
11. Open a command prompt, type `ipconfig`, and press Enter. The local area connection for the IBM USB RNDIS appears with an IP address in the range of 169.254.xxx.xxx with a subnet mask set to 255.255.0.0.

## LAN over USB Linux Driver Installation

Use this information to install the LAN over USB driver for Linux.

Current versions of Linux, such as RHEL5 Update 2 and SLES10 Service Pack 2, support the LAN over USB interface by default. This interface is detected and displayed during the installation of these operating systems. When you configure the device, use a static IP address of 169.254.95.130 with a subnet mask of 255.255.0.0.

**Note:** Older Linux distributions might not detect the LAN over USB interface, and might require manual configuration. For information about configuring LAN over USB on specific Linux distributions, see <http://www-947.ibm.com/support/entry/portal/docdisplay?brand=5000008&Indocid=MIGR-5083207>.



The IMM LAN over USB interface requires that the `usbnet` and `cdc_ether` drivers be loaded. If the drivers have not been installed, use `modprobe` to install them. When these drivers are loaded, the IMM USB network interface shows up as a network device in the operating system. To discover the name that the operating system has assigned to the IMM USB network interface, type:

```
dmesg | grep -i cdc ether
```

The interface is configured with `ifconfig` to have an IP address in the range `169.254.xxx.xxx`. For example:

```
ifconfig IMM_device_name 169.254.1.102 netmask 255.255.0.0
```

This interface is configured to come up with an IP address in the `169.254.xxx.xxx` range each time that the operating system is booted.



---

## Chapter 3. Parts listing

This chapter contains the parts listing for the IBM BladeCenter HS23E blade server.

Replaceable components consist of consumable parts, structural parts, and customer replaceable units (CRUs):

- **Structural parts:** Purchase and replacement of structural parts (components, such as chassis assembly, top cover, and bezel) is your responsibility. If IBM acquires or installs a structural component at your request, you will be charged for the service.
- **Customer replaceable unit (CRU):**
  - **Tier 1 customer replaceable unit:** Replacement of Tier 1 CRUs is your responsibility. If IBM installs a Tier 1 CRU at your request, you will be charged for the installation.
  - **Tier 2 customer replaceable unit:** You may install a Tier 2 CRU yourself or request IBM to install it, at no additional charge, under the type of warranty service that is designated for your server. Some tier 2 CRUs must be installed only by trained technicians.

---

### Parts listing, Type 8038 and 8039

Use this information to remove and replace blade server components.

The following replaceable components are available for the IBM BladeCenter HS23E Type 8038 or 8039 blade server. For an updated parts listing on the web, go to <http://www.ibm.com/supportportal/>.

**Note:** The illustrations in this document might differ slightly from your hardware.

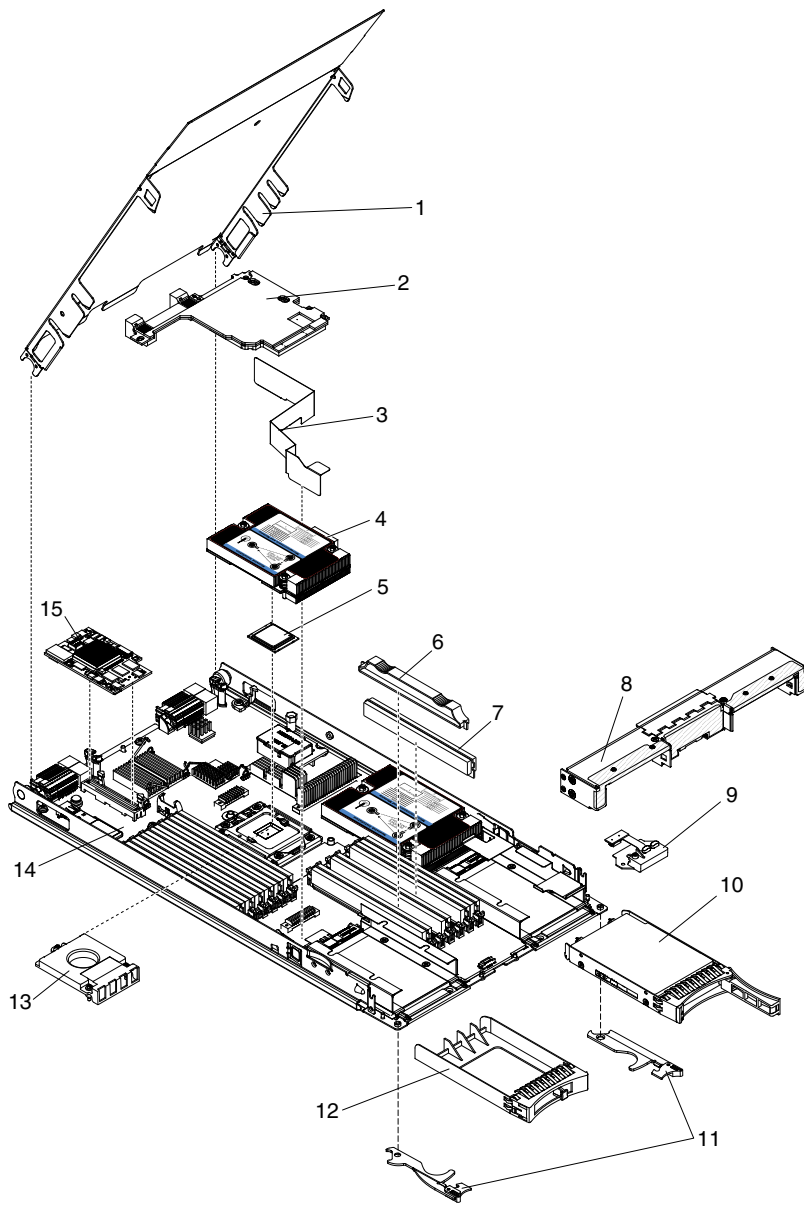

For information about the terms of the warranty and getting service and assistance, see the *Warranty Information* document.

Index	Description	CRU part number (Tier 1)	CRU part number (Tier 2)
2	Expansion card, Intel dual-port 10Gb Ethernet Expansion Card (CFFh)	42C1812	
2	Expansion card, QLogic dual-port 10Gb Converged Network Adapter Cffh	42C1832	
2	Expansion card, QLogic dual-port 10Gb Converged Network Adapter CFFh (option)	00Y3283	
2	Expansion card, 2/4 port Ethernet CFFh (option)	44W4488	
2	Expansion card, QLogic Ethernet and 8 Gb Fibre Channel CFFh (option)	00Y5630	

Index	Description	CRU part number (Tier 1)	CRU part number (Tier 2)
2	Expansion card, QLogic CFFh 8G	00Y5632	
2	Expansion card, Broadcom 10 Gb 4-port Ethernet (CFFh) (BMC 57711)	46M6165	
2	Expansion card, Broadcom 10 Gb 2-port Ethernet (CFFh)	46M6169	
2	Expansion card, Brocade 10Gb Converged Network Adapter (CFFh)	81Y1654	
2	Expansion card, Emulex 10GbE Virtual Fabric Adapter 2 for IBM BladeCenter (CFFh)	00Y3290	
2	Expansion card, Emulex 10GbE Virtual Fabric Adapter Advanced 2 for IBM BladeCenter (CFFh)	00Y3292	
2	Expansion card, Emulex Virtual Fabric Adapter for IBM BladeCenter (CFFh)	00Y3294	
2	Expansion card, Emulex Virtual Fabric Adapter Advanced for IBM BladeCenter (CFFh)	00Y3296	
2	Expansion card, QLogic 2-port 10Gb Virtual Fabric Adapter (CFFh)	00Y3335	
2	Expansion card, QLogic 2-port 10Gb Virtual Fabric Advanced CNA (iSCSI & FCoE) (CFFh)	00Y5621	
4	Heat sink, microprocessor		94Y6221
5	Microprocessor, Intel Xeon Processor E5-2470 8C 2.3GHz 20MB Cache 1600MHz 95W		90Y4736
5	Microprocessor, Intel Xeon Processor E5-2450 8C 2.1GHz 20MB Cache 1600MHz 95W		90Y4738
5	Microprocessor, Intel Xeon Processor E5-2440 6C 2.4GHz 15MB Cache 1333MHz 95W		90Y4739
5	Microprocessor, Intel Xeon Processor E5-2430 6C 2.2GHz 15MB Cache 1333MHz 95W		90Y4740
5	Microprocessor, Intel Xeon Processor E5-2420 6C 1.9GHz 15MB Cache 1333MHz 95W		90Y4742
5	Microprocessor, Intel Xeon Processor E5-2407 4C 2.2GHz 10MB Cache 1066MHz 80W		90Y4743
5	Microprocessor, Intel Xeon Processor E5-2403 4C 1.8GHz 10MB Cache 1066MHz 80W		90Y4744
5	Microprocessor, Intel Pentium Processor 1403 2C 2.6GHz 5MB Cache 1066MHz 80W		90Y4745
5	Microprocessor, Intel Pentium Processor 1407 2C 2.8GHz 5MB Cache 1066MHz 80W		90Y4746
5	Microprocessor, Intel Xeon Processor E5-2450L 8C 1.8GHz 20MB Cache 1600MHz 70W		90Y4747
5	Microprocessor, Intel Xeon Processor E5-2430L 6C 2.0GHz 15MB Cache 1333MHz 60W		90Y4748
5	Microprocessor, Intel Xeon Processor E5-2428L 6C 1.8GHz 15MB Cache 1333MHz 60W		00D8760
5	Microprocessor, Intel Xeon Processor E5-2448L 8C 1.80GHZ 20MB Cache 1600MHz 70W		00D8761
5	Microprocessor, Intel Xeon Processor E5-2418L 4C 2.0GHz 10MB Cache 1333MHz 50W		00D8762

Index	Description	CRU part number (Tier 1)	CRU part number (Tier 2)
5	Microprocessor, Intel Xeon Processor E5-1410 4C 2.8GHz 10MB Cache 1333MHz 80W		00D9038
9	Hard disk drive, 2.5-inch slim hot-swap SAS 300 GB 10K 6 Gbps	42D0638	
9	Hard disk drive, 2.5-inch slim hot-swap SAS 146 GB 15K 6 Gbps	42D0678	
9	Hard disk drive, 2.5-inch slim hot-swap SAS 500 GB SFF	42D0708	
9	Solid-state drive, 2.5-inch slim hot-swap SATA 200 GB	43W7721	
9	Hard disk drive, 2.5-inch slim hot-swap SAS 600 GB 10K 6 Gbps	49Y2004	
9	Hard disk drive, 2.5-inch slim hot-swap SAS 900 GB 10K 6 Gbps	81Y9651	
9	Hard disk drive, 2.5-inch slim hot-swap SAS 300 GB 15K 6 Gbps	81Y9671	
9	Hard disk drive, 2.5-inch slim hot-swap NL SAS 1 TB 7.2K 6 Gbps	81Y9691	
9	Hard disk drive, 2.5-inch slim hot-swap SATA 250 GB 7.2K 6 Gbps	81Y9723	
9	Hard disk drive, 2.5-inch slim hot-swap SATA 500 GB 7.2K 6 Gbps	81Y9727	
9	Hard disk drive, 2.5-inch slim hot-swap NL SATA 1 TB 7.2K 6 Gbps	81Y9731	
9	Hard disk drive, 2.5 inch SFF slim hot-swap SAS 500 GB 7.2K 6 Gbps	00NA587	
9	Solid-state drive, 2.5-inch slim hot-swap SATA 256 GB	90Y8644	
9	Solid-state drive, 2.5-inch slim hot-swap SATA 128 GB	90Y8649	
9	Solid-state drive, 2.5-inch SATA 120 GB MLC HS Enterprise	00AJ356	
9	Solid-state drive, 2.5-inch SATA 240 GB MLC HS Enterprise	00AJ361	
9	Solid-state drive, 2.5-inch SATA 480 GB MLC HS Enterprise	00AJ366	
9	Solid-state drive, 2.5-inch SATA 800 GB MLC HS Enterprise	00AJ371	
9	Solid state drive, 2.5 inch multi level cell hot-swap SATA 1.6 TB	00FN269	
9	Solid state drive, 2.5 inch multi level cell hot-swap SATA 240 GB	00FN299	
9	Solid state drive, 2.5 inch multi level cell hot-swap SATA 480 GB	00FN328	
9	Solid state drive, 2.5 inch multi level cell hot-swap SATA 960 GB	00FN333	
12	Memory, 2 GB 1R x 8 1333 MHz VLP RDIMM 1.35V	46C0572	
12	Memory, 4 GB 1R x 4 1333 MHz VLP RDIMM 1.35V	46C0575	
12	Memory, 4 GB 2R x 8 1333 MHz VLP RDIMM 1.35V	46C0576	
12	Memory, 4 GB 1R x 4 1600 MHz VLP RDIMM 1.5V	90Y3153	
12	Memory, 8 GB 1R x 4 1333 MHz VLP RDIMM 1.35V	00D4983	
12	Memory, 8 GB 2R x 4, 1333 MHz VLP DRIMM 1.35V	46C0580	
12	Memory, 8 GB 2R x 8 1333 MHz VLP RDIMM 1.35V	00D4987	
12	Memory, 8 GB 1R x 4 1600 MHz VLP RDIMM 1.5V	00D4991	
12	Memory, 8 GB 2R x 4 1600 MHz VLP RDIMM 1.5V	90Y3154	
12	Memory, 8 GB 2R x 4 1600 MHz VLP RDIMM 1.5V	90Y3155	
12	Memory, 8 GB 2R x 8 1600 MHz VLP RDIMM 1.5V	00D4995	
12	Memory, 16 GB 4R x 4 1066 MHz VLP RDIMM 1.35V	90Y3223	
12	Memory, 16 GB 2R x 4 1333 MHz VLP RDIMM 1.35V	49Y1528	
12	Memory, 16 GB 2R x 4 1600 MHz VLP RDIMM 1.5V	90Y3159	

Index	Description	CRU part number (Tier 1)	CRU part number (Tier 2)
14	System board (base assembly type 1 for use with Intel Xeon Processor E5-2600 series)  B1x, B3x, C2x, C3x, D1x, D3x, F1x, F2x, E1Y, E2Y, E3Y, C4x, D2x, D4x, E4x, E5x, E6x		00Y7572
14	System board (base assembly type 2 for use with Intel Xeon Processor E5-2600 v2 series)  C4x, D2x, D4x, E4x, E5x, E6x, B1x, B3x, C2x, C3x, D1x, D3x, E1x, E2x, E3x, F1x, F2x		00KC548
15	Expansion card, Emulex 8Gb Fibre Channel Dual-Port CIOv (option)	00JY846	
15	Expansion card, Gigabit Ethernet Expansion Card (CIOv)	44W4487	
15	Expansion card, QLogic 8Gb Combo Fibre Channel Expansion Adapter (CFFh)	44X1943	
15	Expansion card, QLogic 8Gb Fibre Channel Expansion Card (CIOv)	44X1948	
15	Expansion card, QLogic 4Gb Fibre Channel Expansion Card (CIOv)	49Y4237	
15	Expansion card, ServeRAID H1135 (CIOv) controller	90Y4735	
	Alcohol Kit (all models)		59P4739
	Battery, 3.0 volt	33F8354	
	BladeCenter GPU expansion unit	68Y7493	
	BladeCenter PCI Express Gen II expansion unit	68Y7498	
	Grease Kit (all models)		41Y9292
	IBM USB key for VMware ESXi	42D0545	
	Label, system service	00D3732	
	Microprocessor installation tool (option)		59Y4943
	RID tag	68Y8680	

## Structural parts

Consumable and structural parts are not covered by the IBM Statement of Limited Warranty.

Index	Description	Part number
1	Cover	68Y8691
3	Air baffle	00D8893
6	Filler, Microprocessor/heat sink	46C3548
7	Front bezel	46D1141
8	Control panel	90Y2753
10	Blade handles (included in the miscellaneous parts kit)	00D3734
11	Filler, 2.5-inch hot-swap hard disk drive	44T2248
13	Filler, DIMM	60H2962
	Assembly, host channel adapter	60Y0927
	Kit, miscellaneous parts	00D3734

To order a consumable or structural part, go to <http://www.ibm.com>.

If you need help with your order, call the toll-free number that is listed on the retail parts page, or contact your local IBM sales representative or IBM reseller for assistance.



---

## Chapter 4. Removing and replacing blade server components

Use this information to remove and replace components in the blade server.

Replaceable components consist of consumable parts, structural parts, and customer replaceable units (CRUs):

- **Consumables:** Purchase and replacement of consumables (components, such as batteries that have depleting life) is your responsibility. If IBM acquires or installs a consumable component at your request, you will be charged for the service.
- **Structural parts:** Purchase and replacement of structural parts (components, such as chassis assembly, top cover, and bezel) is your responsibility. If IBM acquires or installs a structural component at your request, you will be charged for the service.
- **Customer replaceable unit (CRU):**
  - **Tier 1 customer replaceable unit:** Replacement of Tier 1 CRUs is your responsibility. If IBM installs a Tier 1 CRU at your request, you will be charged for the installation.
  - **Tier 2 customer replaceable unit:** You may install a Tier 2 CRU yourself or request IBM to install it, at no additional charge, under the type of warranty service that is designated for your server. Some tier 2 CRUs must be installed only by trained technicians.

See Chapter 3 “Parts listing” on page 33 to determine whether a component is a consumable, structural, or CRU part.

For information about the terms of the warranty and getting service and assistance, see the *Warranty Information* document.

---

### Installation guidelines

Use these guidelines before you install the blade server or optional devices.

Before you install optional devices, read the following information:

- Before you begin, read “Safety” on page v and “Handling static-sensitive devices” on page 40. This information will help you work safely.
- When you install your new blade server, take the opportunity to download and apply the most recent firmware updates. This step will help to ensure that any known issues are addressed and that your blade server is ready to function at maximum levels of performance. To download firmware updates for your blade server, go to <http://www.ibm.com/supportportal/>.
- Observe good housekeeping in the area where you are working. Place removed covers and other parts in a safe place.
- Back up all important data before you make changes to disk drives.
- Before you remove a blade server from the BladeCenter unit, you must shut down the operating system and turn off the blade server. You do not have to shut down the BladeCenter unit itself.
- Blue on a component indicates touch points, where you can grip the component to remove it from or install it in the blade server, open or close a latch, and so on.
- Orange on a component or an orange label on or near a component indicates that the component can be hot-swapped, which means that if the server and operating system support hot-swap capability, you can remove or install the component while the server is running. (Orange can also indicate touch points on hot-swap components.) See the instructions for removing or installing a specific hot-swap component for any additional procedures that you might have to perform before you remove or install the component.

- For a list of supported optional devices for the blade server, see <http://www.ibm.com/systems/info/x86servers/serverproven/compat/us/>.

## System reliability guidelines

Use this information to make sure that the blade server meets the proper cooling and reliability guidelines.

To help make sure that proper cooling and system reliability requirements are met, review the following guidelines:

- To ensure proper cooling, do not operate the BladeCenter unit without a blade server, expansion unit, or blade filler installed in each blade-server bay. See the documentation for your BladeCenter unit for additional information.
- Each microprocessor socket always contains either a microprocessor dust cover and heat sink filler or a microprocessor and heat sink. If the blade server has only one microprocessor, it must be installed in microprocessor socket 1.
- Each DIMM socket always contains a memory module or filler.
- Each hot-swap SAS bay contains a SAS storage drive or filler.
- Make sure that the ventilation holes on the blade server are not blocked.
- The blade server battery must be operational. If the battery becomes defective, replace it immediately.

## Handling static-sensitive devices

Use this information to observe the static-sensitive device requirements.

**Attention:** Static electricity can damage the blade server and other electronic devices. To avoid damage, keep static-sensitive devices in their static-protective packages until you are ready to install them.

To reduce the possibility of damage from electrostatic discharge, observe the following precautions:

- When you work on a BladeCenter unit that has an electrostatic discharge (ESD) connector, use a wrist strap, especially when you handle modules, optional devices, or blade servers. To work correctly, the wrist strap must have a good contact at both ends (touching your skin at one end and firmly connected to the ESD connector on the front or back of the BladeCenter unit).
- Limit your movement. Movement can cause static electricity to build up around you.
- Handle the device carefully, holding it by its edges or its frame.
- Do not touch solder joints, pins, or exposed circuitry.
- Do not leave the device where others can handle and damage it.
- While the device is still in its static-protective package, touch it to an *unpainted* metal part of the BladeCenter unit or any *unpainted* metal surface on any other grounded rack component in the rack in which you are installing the device for at least 2 seconds. This drains static electricity from the package and from your body.
- Remove the device from its package and install it directly into the blade server without setting down the device. If it is necessary to set down the device, put it back into its static-protective package. Do not place the device on the blade server cover or on a metal surface.
- Take additional care when you handle devices during cold weather. Heating reduces indoor humidity and increases static electricity.

## Returning a device or component

Use this information for instructions to return a device or component to service and support.

If you are instructed to return a device or component, follow all packaging instructions, and use any packaging materials for shipping that are supplied to you.

---

## Removing the blade server from the BladeCenter unit

Use these instructions to remove the blade server from the BladeCenter unit.

The following illustration shows how to remove a single-width type of blade server or blade filler from a BladeCenter unit. The appearance of your BladeCenter unit might be different; see the documentation for your BladeCenter unit for additional information.

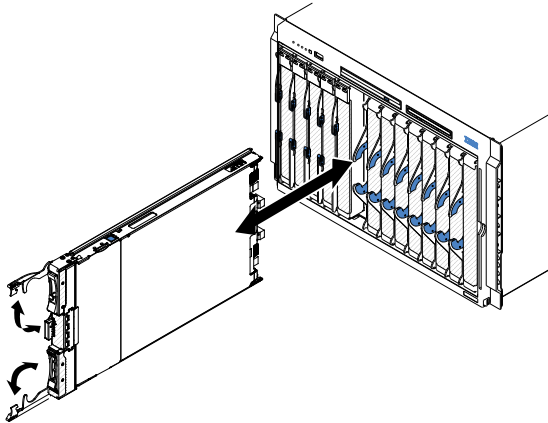

### Attention:

- To maintain proper system cooling, do not operate the BladeCenter unit without a blade server, expansion unit, or filler module installed in each blade server bay.
- When you remove the blade server, note the blade-server bay number. Reinstalling a blade server into a different blade server bay from the one it was removed from can have unintended consequences. Some configuration information and update options are established according to blade-server bay number; if you reinstall the blade server into a different bay, you might have to reconfigure the blade server.

To remove the blade server, complete the following steps:

Step 1. If the blade server is operating, shut down the operating system (see the documentation for your operating system for more information).

Step 2. If the server is still on, press the power button for four seconds to turn off the blade server (see “Turning off the blade server” on page 7 for more information).

**Attention:** Wait at least 30 seconds, until the storage devices stops spinning, before you proceed to the next step.

Step 3. Open the two release handles as shown in the illustration. The blade server moves out of the blade server bay approximately 0.6 cm (0.25 inch).

Step 4. Pull the blade server out of the bay.

Step 5. Place either a blade filler or another blade server in the blade server bay within 1 minute.

---

## Installing the blade server in a BladeCenter unit

Use these instructions to install the blade server in a BladeCenter unit.

The following illustration shows how to install a blade server into a BladeCenter unit. The appearance of your BladeCenter unit might be different; see the documentation for your BladeCenter unit for additional information. To install a blade server in a BladeCenter unit, complete the following steps.

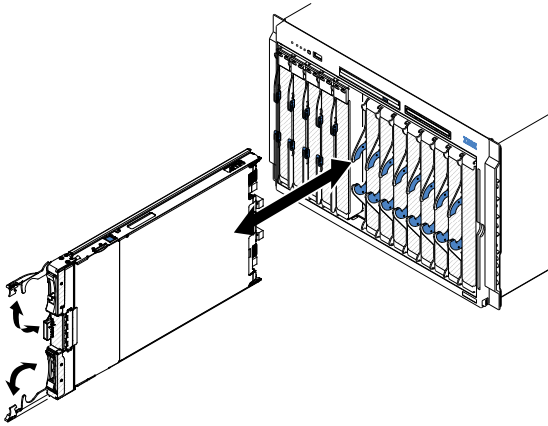

#### Statement 21



#### CAUTION:

**Hazardous energy is present when the blade server is connected to the power source. Always replace the blade cover before installing the blade server.**

- Step 1. Before you begin, read “Safety” on page v and “Installation guidelines” on page 39.
- Step 2. Select the blade bay for the blade server; at least one blade bay is required.

#### Notes:

1. When any blade server or device is in blade bay 7 through 14, power modules must be installed in all four power-module bays. For additional information, see the *Installation and User's Guide* that comes with the BladeCenter unit.
2. If you are reinstalling a blade server that you removed, you must install it in the same blade bay from which you removed it. Some blade server configuration information and update options are established according to blade server bay number. Reinstalling a blade server into a different blade server bay number from the one which it was removed can have unintended consequences, and you might have to reconfigure the blade server.
3. To help ensure proper cooling, performance, and system reliability, make sure that each blade bay on the front of the BladeCenter unit contains a blade server, expansion unit, or blade filler. Do not operate a BladeCenter unit for more than 1 minute without a blade server, expansion unit, or blade filler in each blade bay.

- Step 3. Make sure that the release handles on the blade server are in the open position (perpendicular to the blade server).
- Step 4. Slide the blade server into the blade bay until it stops.
- Step 5. Push the release handles on the front of the blade server to the closed position.

**Note:** After the blade server is installed, the IMM2 in the blade server initializes and synchronizes with the management module. This process takes approximately two minutes to complete. The

power LED flashes rapidly, and the power-control button on the blade server does not respond until this process is complete.

- Step 6. Turn on the blade server (see “Turning on the blade server” on page 6 for instructions).
- Step 7. Make sure that the power LED on the blade server control panel is lit continuously, indicating that the blade server is receiving power and is turned on.
- Step 8. If you have other blade servers to install, do so now.
- Step 9. Write identifying information on one of the labels that come with the blade servers and place the label on the BladeCenter unit bezel. See the documentation for your BladeCenter unit for information about the label placement.

**Important:** Do not place the label on the blade server or in any way block the ventilation holes on the blade server.

If you have changed the configuration of the blade server or if you are installing a different blade server from the one that you removed, you must configure the blade server through the Setup utility, and you might have to install the blade server operating system. Detailed information about these tasks is available in the *Installation and User's Guide*.

---

## Removing and replacing consumable and structural parts

Replacement of consumable parts and structural parts is your responsibility. If IBM installs a consumable part or structural part at your request, you will be charged for the installation.

The illustrations in this document might differ slightly from the hardware.

### Removing the blade server cover

Use these instructions to open the blade server cover.

The following illustration shows how to open the cover on the blade server.

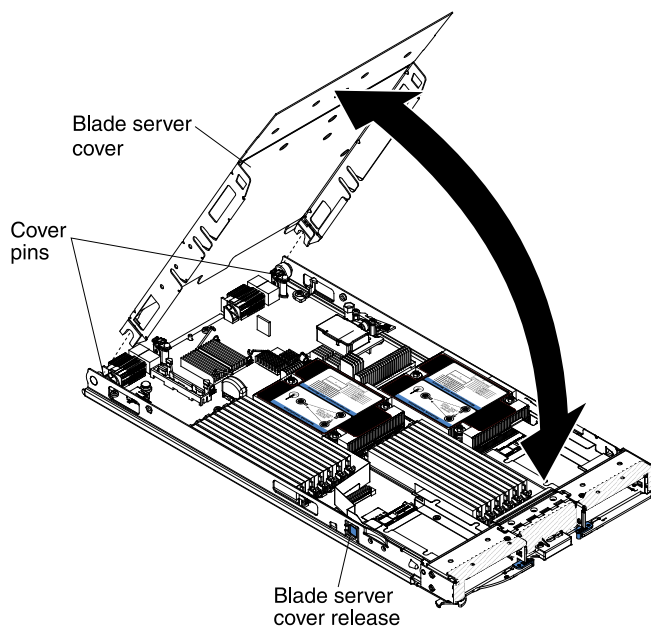

To open the blade server cover, complete the following steps:

- Step 1. Before you begin, read “Safety” on page v and “Installation guidelines” on page 39.
- Step 2. If the blade server is installed in a BladeCenter unit, remove it (see “Removing the blade server from the BladeCenter unit” on page 41 for instructions).
- Step 3. Carefully lay the blade server on a flat, static-protective surface, with the cover side up.
- Step 4. Press the blade server cover release on each side of the blade server or expansion unit and lift the cover open, as shown in the illustration.
- Step 5. Lay the cover flat, or lift it from the blade server and store for future use.

#### Statement 21



#### CAUTION:

**Hazardous energy is present when the blade server is connected to the power source. Always replace the blade cover before installing the blade server.**

### Installing the blade server cover

Use these instructions for information about how to close the blade server cover.

**Attention:** You cannot insert the blade server into the BladeCenter unit until the cover is installed and closed or an expansion unit is installed. Do not attempt to override this protection.

To install the blade server cover, complete the following steps:

- Step 1. Close the DIMM access door by rotating the door towards the DIMM connectors.

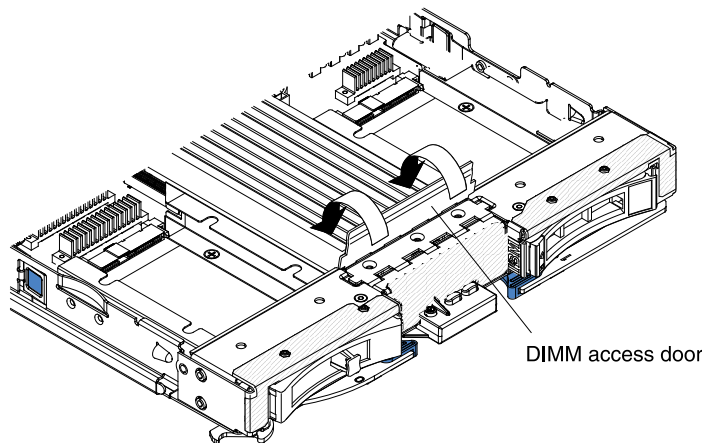

- Step 2. If you removed an expansion unit from the blade server, install it now (see “Installing an optional expansion unit” on page 69).
- Step 3. Lower the cover so that the slots at the rear slide down onto the pins at the rear of the blade server, as shown in the illustration. Before you close the cover, make sure that all components are installed and seated correctly and that you have not left loose tools or parts inside the blade server.
- Step 4. Pivot the cover to the closed position, as shown in the illustration, until it clicks into place. Press down the cover to make sure the cover is installed securely.

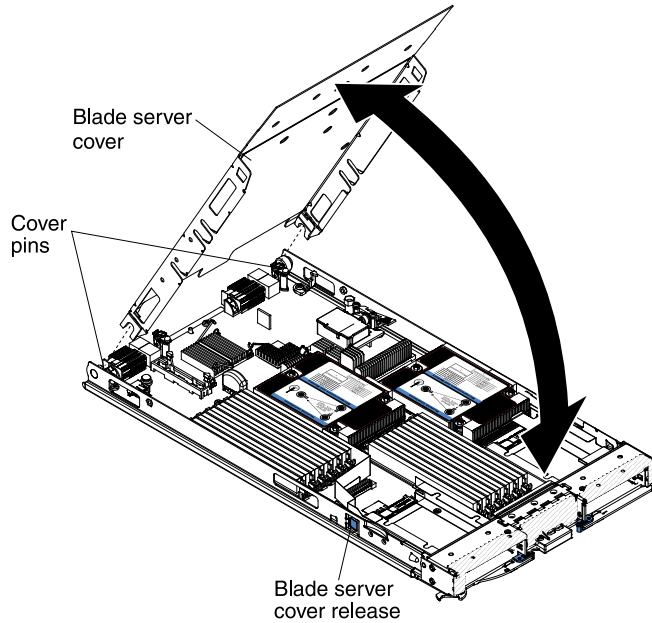

Step 5. Install the blade server into the BladeCenter unit (see “Installing the blade server in a BladeCenter unit” on page 41).

## Removing the bezel assembly

Use this information to remove the bezel assembly from the blade server.

The following illustration shows how to remove a bezel assembly from a blade server.

**Note:** The illustrations in this document might differ slightly from your hardware.

To remove the bezel assembly, complete the following steps.

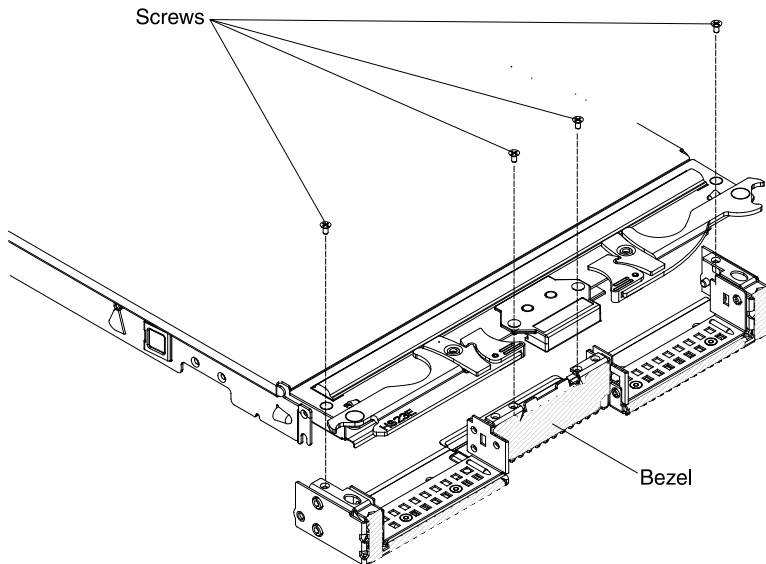

Step 1. Before you begin, read “Safety” on page v and “Installation guidelines” on page 39.

- Step 2. If the blade server is installed in a BladeCenter unit, remove it (see “Removing the blade server from the BladeCenter unit” on page 41 for instructions).
- Step 3. Carefully lay the blade server on a flat, static-protective surface, with the cover side down.
- Step 4. Open the blade server cover (see “Removing the blade server cover” on page 43 for instructions).
- Step 5. If an optional expansion unit is installed, remove it (see “Removing an optional expansion unit” on page 68).
- Step 6. If a hot-swap storage drive or a storage drive filler is installed, remove it (see “Removing a hot-swap storage drive” on page 53).
- Step 7. If an optional expansion unit is installed, remove it (see “Removing an optional expansion unit” on page 68).
- Step 8. Locate the four screws that secure the bezel assembly to the blade server base assembly.
- Step 9. Use a screwdriver to remove the four screws that secure the bezel assembly to the blade server base assembly. Save the screws in a safe place. It is recommended to use the same screws when installing the bezel assembly.
- Step 10. While holding the bezel assembly and the blade server, rotate the blade server so that the cover side is up.
- Step 11. Lift the bezel assembly away from the blade server.
- Step 12. If you are instructed to return the bezel assembly, follow all packaging instructions, and use any packaging materials for shipping that are supplied to you.

## Installing the bezel assembly

Use this information to install a bezel assembly in the blade server.

### Notes:

1. The following illustration shows how to install a bezel assembly in a blade server.
2. The illustrations in this document might differ slightly from your hardware.

To install the bezel assembly, complete the following steps.

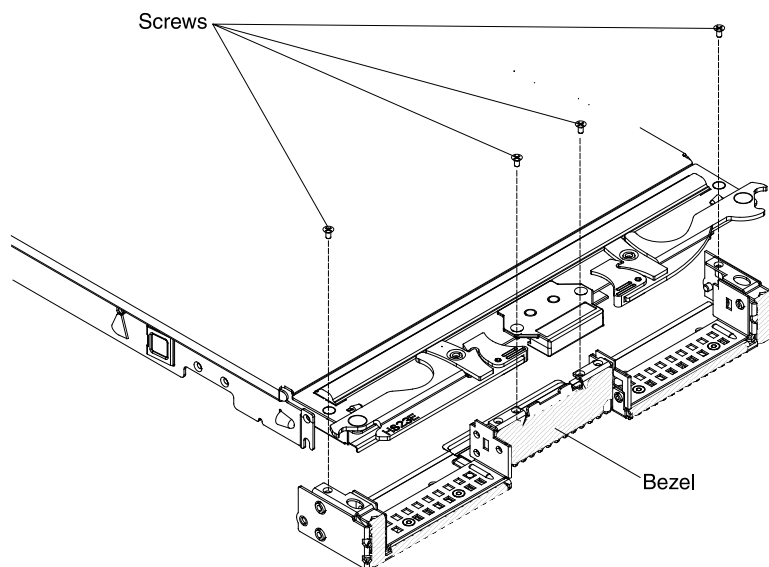

- Step 1. If the control panel was removed, install it (see “Installing the control panel” on page 67).



- Step 2. Orient the bezel with the front of the blade server, aligning the screw holes on the bezel with the holes on the blade server.
- Step 3. Use your hand to keep the bezel assembly tight against the blade server; then, rotate the blade server so that the bottom is now facing up.
- Step 4. Use a screwdriver to install the four screws that secure the bezel assembly to the blade server. It is recommended to use the same screws that were removed when the bezel assembly was removed.
- Step 5. Orient the blade server so that the bottom of the blade server is down.
- Step 6. Install the optional expansion unit, if you removed one from the blade server (see “Installing an optional expansion unit” on page 69 for instructions).
- Step 7. Install the cover onto the blade server (see “Installing the blade server cover” on page 44).
- Step 8. Install the blade server into the BladeCenter unit (see “Installing the blade server in a BladeCenter unit” on page 41).

## Removing a blade handle

Use these instructions to remove a blade handle.

The following illustration shows how to remove a blade handle.

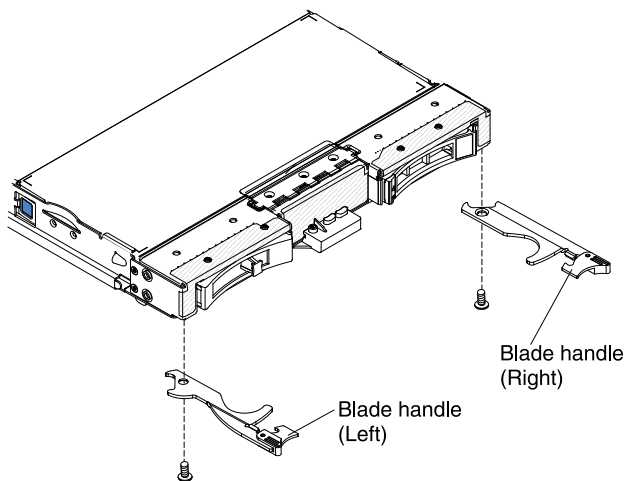

To remove a blade handle, complete the following steps.

- Step 1. Before you begin, read “Safety” on page v and “Installation guidelines” on page 39.
- Step 2. If the blade server is installed in a BladeCenter unit, remove it (see “Removing the blade server from the BladeCenter unit” on page 41 for instructions).
- Step 3. Carefully lay the blade server on a flat, static-protective surface, with the cover side down.
- Step 4. Locate the blade handle that you will be removing.
- Step 5. Locate the screw that attaches the blade handle to the blade server.
- Step 6. Remove the screw from the blade handle and save the screw in a safe place. It is recommended to use the same screw when installing a blade handle.
- Step 7. If you are instructed to return the blade handle, follow all packaging instructions, and use any packaging materials for shipping that are supplied to you.

## Installing a blade handle

Use these instructions for information about how install a blade handle.

To install a blade handle, complete the following steps:

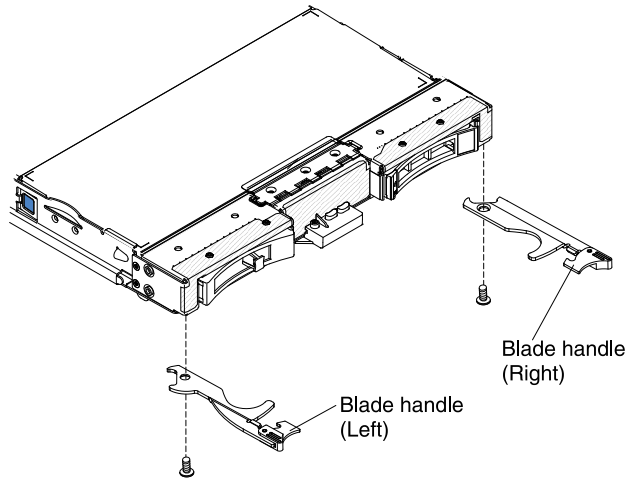

Step 1. Orient the blade server with the cover side down and the bezel towards you.

Step 2. Locate where you will be installing the blade handle.

**Note:** The left handle and right handle are not the same part. To identify where the blade handle should be installed, see the illustration and parts listing provided in Chapter 3 “Parts listing” on page 33.

Step 3. Orient the blade handle so that the blue release latch is towards the middle of the blade server.

Step 4. Align the hole in the blade handle with the hole on the blade server where the handle will be installed.

Step 5. Use a screwdriver to install the screw that secures the blade handle to blade server. It is recommended to install the screw that was removed when the blade handle was removed.

Step 6. Install the blade server into the BladeCenter unit (see “Installing the blade server in a BladeCenter unit” on page 41).

## Removing the air baffle

Use this information to remove the air baffle from the blade server.

The following illustration shows how to remove a air baffle from a blade server.

**Note:** The illustrations in this document might differ slightly from your hardware.

To remove the air baffle, complete the following steps.

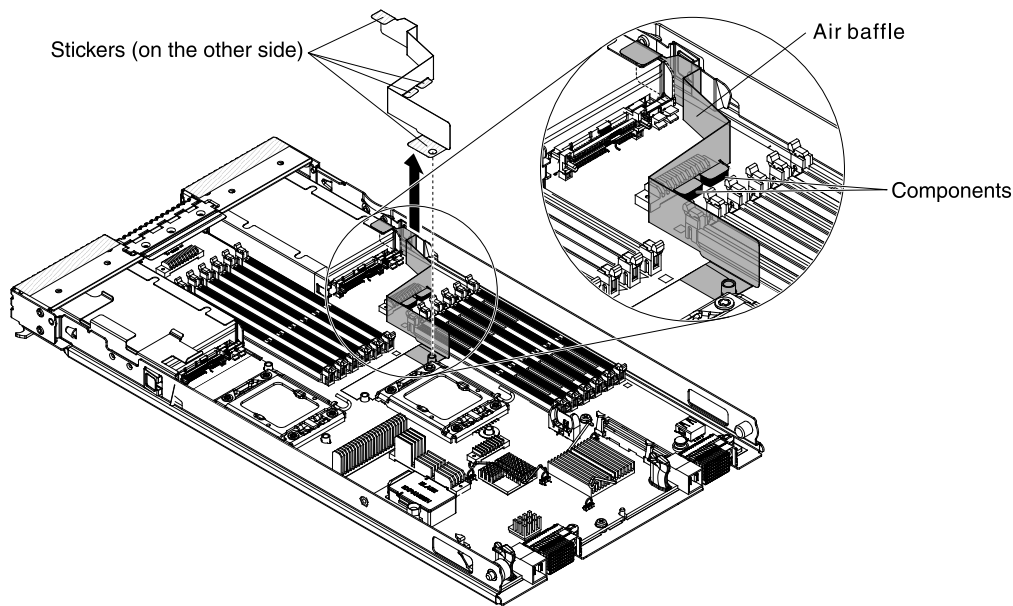

- Step 1. Before you begin, read “Safety” on page v and “Installation guidelines” on page 39.
- Step 2. If the blade server is installed in a BladeCenter unit, remove it (see “Removing the blade server from the BladeCenter unit” on page 41 for instructions).
- Step 3. Carefully lay the blade server on a flat, static-protective surface, with the cover side down.
- Step 4. Open the blade server cover (see “Removing the blade server cover” on page 43 for instructions).
- Step 5. Remove heat sink 1 (see “Removing a microprocessor and heat sink” on page 70 for instructions).
- Step 6. Slightly disengage the air baffle stickers from the system board.
- Step 7. Pull the air baffle up to remove it out of the blade server.
- Step 8. If you are instructed to return the air baffle, follow all packaging instructions, and use any packaging materials for shipping that are supplied to you.

## Installing the air baffle

Use this information to install a air baffle in the blade server.

1. The following illustration shows how to install the air baffle in a blade server.
2. The illustrations in this document might differ slightly from your hardware.

To install the air baffle, complete the following steps.

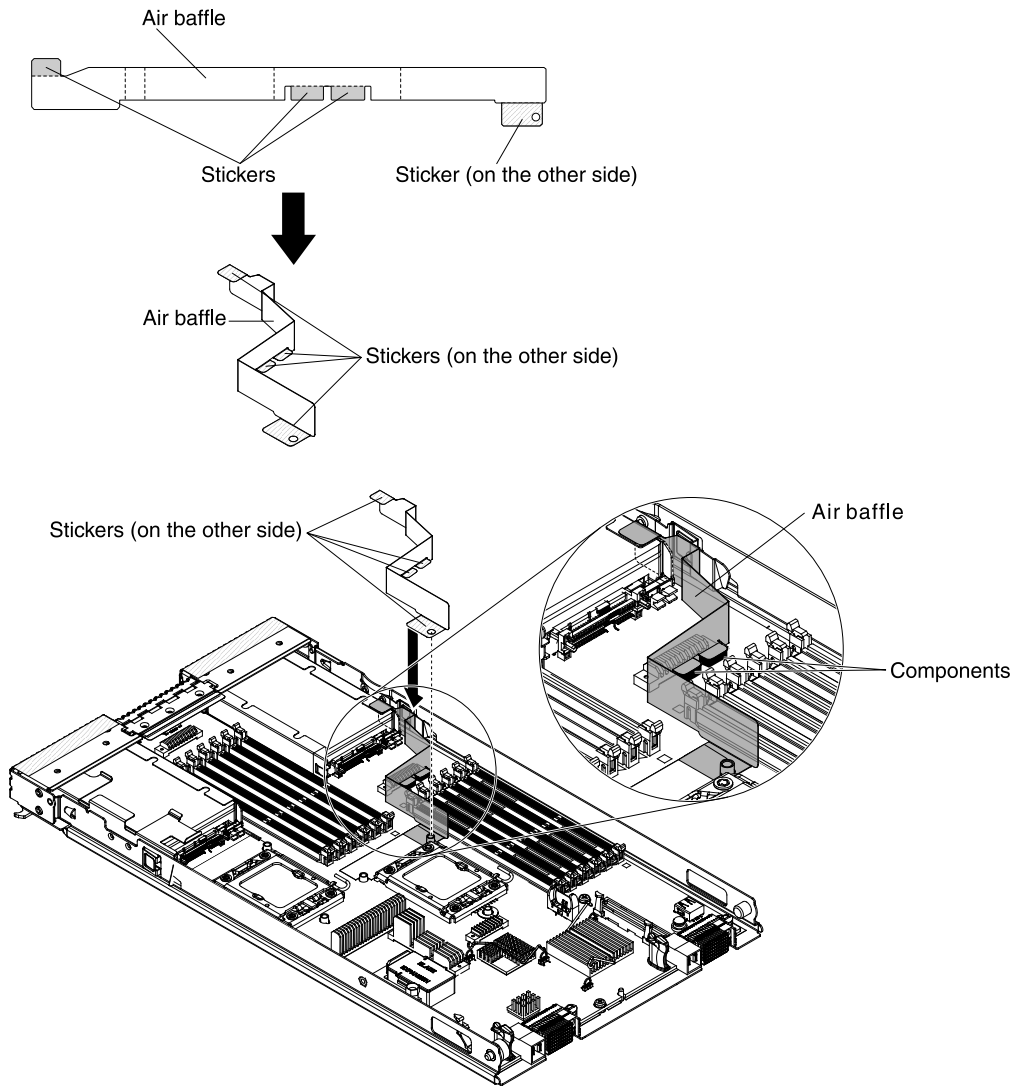

- Step 1. Bend the air baffle (as shown in the illustration).
- Step 2. Remove the 4 sticker covers from the air baffle.
- Step 3. Align the hole on the air baffle with the system board (as shown in the illustration).
- Step 4. Stick the air baffle on the system board, components, and the storage filler. Make sure the air baffle is installed securely.
- Step 5. Install heat sink 1 (see “Installing a microprocessor and heat sink” on page 73).
- Step 6. Install the cover onto the blade server (see “Installing the blade server cover” on page 44).
- Step 7. Install the blade server into the BladeCenter unit (see “Installing the blade server in a BladeCenter unit” on page 41).

---

## Removing and replacing Tier 1 customer replaceable units (CRUs)

Use this information for removing and replacing Tier 1 CRUs.

Replacement of Tier 1 CRUs is your responsibility. If IBM installs a Tier 1 CRU at your request, you will be charged for the installation.

Some Tier 1 CRUs are available as both optional devices and replaceable components. You can use the installation instructions for the Tier 1 CRU to install the optional device.

## Removing the battery

Use this information to remove the battery from the blade server.

To remove the battery, complete the following steps.

- Step 1. Before you begin, read “Safety” on page v and “Installation guidelines” on page 39.
- Step 2. If the blade server is installed in a BladeCenter unit, remove it (see “Removing the blade server from the BladeCenter unit” on page 41 for instructions).
- Step 3. Remove the blade server cover (see “Removing the blade server cover” on page 43 for instructions).
- Step 4. If an optional expansion unit is installed, remove the expansion unit (see “Removing an optional expansion unit” on page 68).
- Step 5. Locate the battery on the system board (see “Blade server connectors” on page 7).
- Step 6. If there is a plastic cover on the battery holder, use your fingers to lift the battery cover from the battery connector.
- Step 7. Release the battery by using your finger to press the top of the battery towards the middle of the blade server and out of the battery connector.

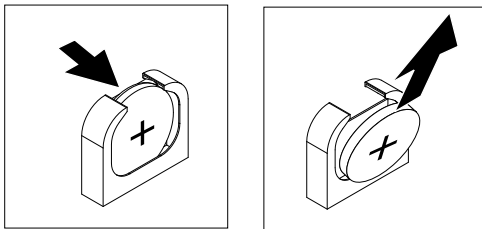

- Step 8. Use your thumb and index finger to lift the battery from the socket.
- Step 9. Dispose of the battery as required by local ordinances or regulations.

## Installing the battery

Use this information to install a battery on the system board in the blade server.

The following notes describe information that you must consider when you are replacing the battery in the blade server.

- You must replace the battery with a lithium battery of the same type from the same manufacturer.
- To order replacement batteries, call 1-800-426-7378 within the United States, and 1-800-465-7999 or 1-800-465-6666 within Canada. Outside the U.S. and Canada, call your IBM sales representative or IBM reseller.
- After you replace the battery, you must reconfigure the blade server and reset the system date and time.
- To avoid possible danger, read and follow the following safety statement.

### Statement 2



**CAUTION:**

When replacing the lithium battery, use only IBM Part Number 33F8354 or an equivalent type battery recommended by the manufacturer. If your system has a module containing a lithium battery, replace it only with the same module type made by the same manufacturer. The battery contains lithium and can explode if not properly used, handled, or disposed of.

**Do not:**

- Throw or immerse into water
- Heat to more than 100° C (212° F)
- Repair or disassemble

Dispose of the battery as required by local ordinances or regulations.

**Notes:**

1. The following illustration shows how to install the battery in the system board.
2. The illustrations in this document might differ slightly from your hardware.

To install the battery, complete the following steps:

- Step 1. Before you begin, read “Safety” on page v and “Installation guidelines” on page 39.
- Step 2. If the blade server is installed in a BladeCenter unit, remove it (see “Removing the blade server from the BladeCenter unit” on page 41 for instructions).
- Step 3. Remove the blade server cover (see “Removing the blade server cover” on page 43 for instructions).
- Step 4. If an optional expansion unit is installed, remove the expansion unit (see “Removing an optional expansion unit” on page 68 for instructions).
- Step 5. Follow any special handling and installation instructions that come with the battery.
- Step 6. Locate the battery on the system board (see “Blade server connectors” on page 7).
- Step 7. Orient the battery so that the positive (+) side faces in towards the center of the blade server.
- Step 8. Tilt the battery so that you can insert it into the bottom of the socket.
- Step 9. As you slide the battery into place, press the top of the battery into the socket.

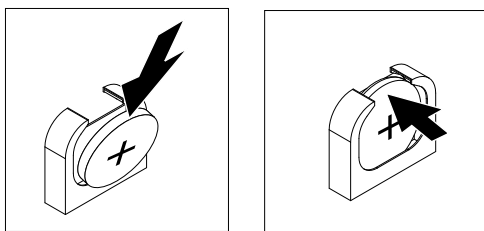

- Step 10. If you removed a plastic cover from the battery holder, use your fingers to install the battery cover on top of the battery connector.
- Step 11. Install the optional expansion unit, if you removed one from the blade server to replace the battery (see “Installing an optional expansion unit” on page 69 for instructions).
- Step 12. Install the cover onto the blade server (see “Installing the blade server cover” on page 44).
- Step 13. Install the blade server into the BladeCenter unit (see “Installing the blade server in a BladeCenter unit” on page 41).
- Step 14. Turn on the blade server, start the Setup utility, and reset the configuration (see “Using the Setup utility” on page 11 for instructions).

## Removing a hot-swap storage drive

Use this information to remove a hot-swap storage drive.

The blade server has two hot-swap storage bays for installing or removing hot-swap storage devices. To remove a hot-swap hard disk drive or drive filler, complete the following steps.

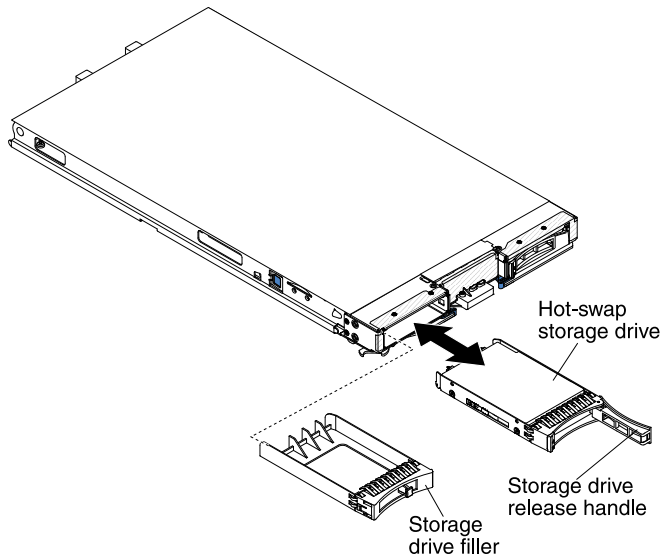

- Step 1. Before you begin, read “Safety” on page v and “Installation guidelines” on page 39.
- Step 2. If possible, save the data on your drive, especially if it is part of a RAID array, before you remove it from the blade server.
- Step 3. Press the release latch (orange) on the storage drive to release the drive handle.
- Step 4. Pull the release handle to remove the drive from the storage bay.
- Step 5. If you are instructed to return the storage drive, follow all packaging instructions, and use any packaging materials for shipping that are supplied to you.

## Installing a hot-swap storage drive

Use these instructions to install a hot-swap storage drive into the blade server.

The blade server has two storage bays for installing hot-swap storage drives. One storage drive might already be installed in the blade server in storage bay 0. If the blade server is equipped with one storage drive, you can install an additional drive in storage bay 1. The blade server supports using RAID 0 or RAID 1 when two storage drives of the same interface type are installed. See “Creating a RAID array of hard disk drives” on page 26 for information about SAS RAID configuration.

To install a hot-swap storage drive or drive filler, complete the following steps.

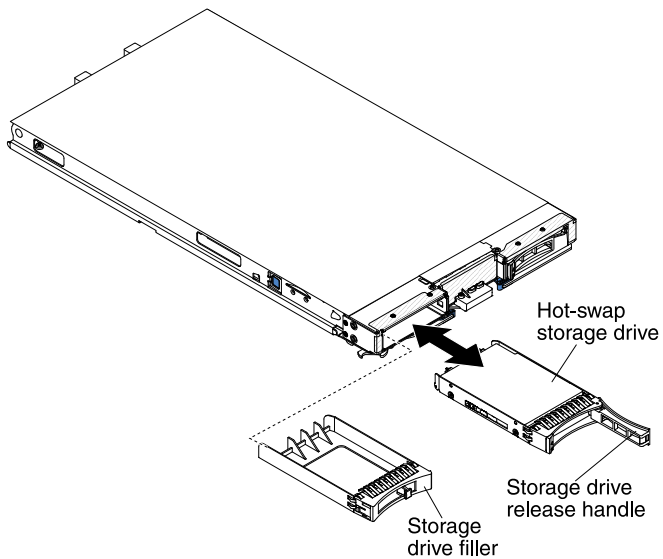

- Step 1. Identify the storage bay (storage bay 0 or storage bay 1) in which the hot-swap storage drive will be installed (see “Blade server connectors” on page 7).
- Step 2. If a storage-drive filler is installed, remove it from the blade server by pulling the release lever and sliding the filler away from the blade server (see “Removing a hot-swap storage drive” on page 53).
- Step 3. Touch the static-protective package that contains the hot-swap storage drive to any *unpainted* metal surface on the BladeCenter unit or any *unpainted* metal surface on any other grounded rack component; then, remove the hard disk drive from the package.
- Step 4. Open the release lever on the hot-swap storage drive and slide the drive into the storage bay until it is firmly seated in the connector.
- Step 5. Lock the hot-swap storage drive into place by closing the release lever.

## Removing a memory module

Use this information to remove a dual inline memory module (DIMM) from the blade server.

The following illustration shows how to remove a DIMM from the blade server. This information also applies to removing a DIMM filler.

After you install or remove a DIMM, you must change and save the new configuration information by using the Setup utility. When you turn on the blade server, a message indicates that the memory configuration has changed. Start the Setup utility and select **Save Settings** (see “Using the Setup utility” on page 11 for more information) to save changes.



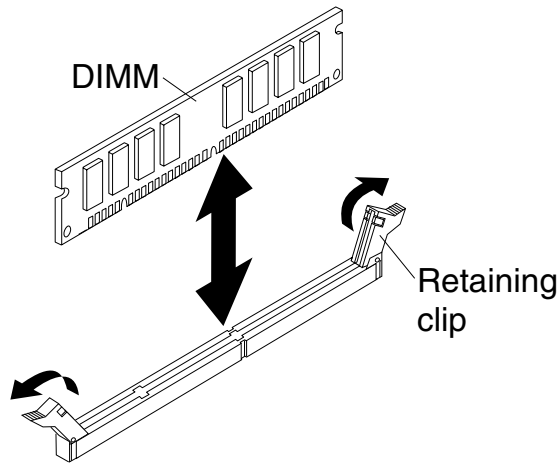

To remove a DIMM, complete the following steps:

- Step 1. Before you begin, read “Safety” on page v and “Installation guidelines” on page 39.
  - Step 2. If the blade server is installed in a BladeCenter unit, remove it (see “Removing the blade server from the BladeCenter unit” on page 41).
  - Step 3. Remove the blade server cover (see “Removing the blade server cover” on page 43).
  - Step 4. If an optional expansion unit is installed, remove the expansion unit (see “Removing an optional expansion unit” on page 68).
  - Step 5. Locate the DIMM connectors (see “Blade server connectors” on page 7). Determine which DIMM you want to remove from the blade server.
 

**Attention:** To avoid breaking the retaining clips or damaging the DIMM connectors, handle the clips gently.
  - Step 6. Move the retaining clips on the ends of the DIMM connector to the open position by pressing the retaining clips away from the center of the DIMM connector.
  - Step 7. Using your fingers, pull the DIMM out of the connector.
  - Step 8. Install a DIMM or DIMM filler in each empty DIMM connector (see “Installing a memory module” on page 55).
- Note:** A DIMM or DIMM filler must occupy each DIMM socket before the blade server is turned on.
- Step 9. If you are instructed to return the DIMM, follow all packaging instructions, and use any packaging materials for shipping that are supplied to you.

## Installing a memory module

Use these instructions to install memory modules in the blade server.

The blade server has a total of twelve direct inline memory module (DIMM) slots. The blade server supports very low profile (VLP) DDR3 single-rank, dual-rank, or quad-rank DIMMs with error code correction (ECC) in 2 GB, 4 GB, 8 GB, and 16 GB capacities. For a list of supported DIMMs for the blade server, see Chapter 3 “Parts listing” on page 33.

**Note:** Do not mix DIMMs with different DDR3 voltages, frequencies, and ECC modes.

In BladeCenter E, not all memory option supported on HS23E are supported in all configurations. CPU throttling may occur within the BladeCenter E's ambient air temperature specification range if these limitations are not followed as below:

- **DIMM:**

- IBM option part number 90Y3221 (CRU part number 90Y3223) - 16 GB 4R x 4 1066 MHz VLP RDIMM 1.35V.

- **Limitation:**

- Not supported with two 95W microprocessors and two DIMMs per channel in BladeCenter E.
- Supported with one 95W microprocessor and two DIMMs per channel (up to 6 DIMMs attached to microprocessor 1) or two 95W microprocessors with one DIMM per channel (up to 3 DIMMs attached to microprocessor 1 and 3 DIMMs attached to microprocessor 2) with DIMM fillers removed in empty DIMM connectors of microprocessor 2.

After you install or remove a DIMM, you must change and save the new configuration information by using the Setup utility. When you turn on the blade server, a message indicates that the memory configuration has changed. Start the Setup utility and select **Save Settings** (see “Setup utility menu” on page 12 for more information) to save changes.

The memory is accessed internally through the system using three channels per microprocessor. Each channel contains two DIMM connectors. The following table lists each channel and which DIMM connectors belong to the channel.

Table 2. Memory channel configuration

Memory channel	DIMM connector (microprocessor 1)	DIMM connector (microprocessor 2)
Channel 1	1 and 2	7 and 8
Channel 2	3 and 4	9 and 10
Channel 3	5 and 6	11 and 12

Depending on the memory mode that is set in the Setup utility, the blade server can support a minimum of 2 GB and a maximum of 96 GB of system memory on the system board in a blade server with one microprocessor. If two microprocessors are installed, the blade server can support a minimum of 4 GB and a maximum of 192 GB of system memory. There are three different memory modes:

- **Independent channel mode:** Independent channel mode gives a maximum of 96 GB of usable memory with one microprocessor installed, and 192 GB of usable memory with two microprocessors installed (using 16 GB DIMMs). The DIMMs can be installed without matching sizes. See the table below for the memory installation order.

Table 3. Independent channel mode DIMM installation sequence

One microprocessor installed	Two microprocessors installed
DIMM connectors 5, 3, 1, 6, 4, 2	DIMM connectors 5, 11, 3, 9, 1, 7, 6, 12, 4, 10, 2, 8

- **Rank sparing mode:** In rank-sparing mode, one memory DIMM rank serves as a spare of the other ranks on the same channel. The spare rank is held in reserve and is not used as active memory. The spare rank must have identical or larger memory capacity than all the other active memory ranks on the same channel. After an error threshold is surpassed, the contents of that rank is copied to the spare rank. The failed rank of memory is taken offline, and the spare rank is put online and used as active memory in place of the failed rank.

**Notes:** Rank sparing mode is supported if the blade server meets one of the following memory requirements:

- One quad-rank DIMM
- More than one DIMM per channel

- An even number of single-rank or dual-rank DIMMs

For rank sparing mode memory installation order on a blade server with quad-rank DIMMs, see Table 3 “Independent channel mode DIMM installation sequence” on page 56.

The following tables show the order that single-rank or dual-rank DIMMs are installed to use rank sparing mode:

Table 4. Rank sparing mode DIMM installation sequence for single-rank or dual-rank DIMMs (one microprocessor)

DIMM pair	DIMM connector
First	5, 6
Second	3, 4
Third	1, 2

Table 5. Rank sparing mode DIMM installation sequence for single-rank or dual-rank DIMMs (two microprocessors)

DIMM pair	DIMM connector
First	5, 6 11, 12
Second	3, 4
Third	9, 10
Fourth	1, 2
Fifth	7, 8

**Note:** In rank sparing mode, if any of the installed DIMMs does not meet the requirements listed above, the system is executed as independent channel mode.

- **Mirrored channel mode:** In mirrored channel mode, memory is installed in pairs. Each DIMM in a pair must be identical in capacity, type, and rank count. The channels are grouped in pairs with each channel receiving the same data. One channel is used as a backup of the other, which provides redundancy. The memory contents on channel 2 are duplicated in channel 3. Channel 1 DIMM connectors 1, 2, 7, and 8 are not used in mirrored channel mode. The maximum available memory (with 16 GB DIMMs) is 32 GB for a single microprocessor system and 64 GB for a dual microprocessor system.

**Important:** The memory configuration of channel 2 must match that of channel 3. For example, if a 4 GB Dual Rank DIMM is installed into the DIMM connector 3 (channel 2), then a 4 GB Dual Rank DIMM must also be installed into the DIMM connector 5 (channel 3). Table 2 “Memory channel configuration” on page 56 lists each channel and which DIMM connectors belong to the channel.

The following table shows the order that memory DIMMs are installed to use mirrored channel mode.

Table 6. System memory configuration for mirrored channel mode (one microprocessor)

DIMM pair	DIMM connector
First	3 and 5
Second	4 and 6

Table 7. System memory configuration for mirrored channel mode (two microprocessors)

DIMM pair	DIMM connector
First	3 and 5, 9 and 11
Second	4 and 6
Third	10 and 12

**Note:** In mirrored channel mode, if any of the installed DIMMs does not meet the requirements listed above, the system is executed as independent channel mode.

To install a DIMM, complete the following steps:

Step 1. Locate the DIMM connectors (see “Blade server connectors” on page 7). Determine which DIMM connector you will be installing memory into.

Step 2. If a DIMM filler or another memory module is already installed in the DIMM connector, remove it (see “Removing a memory module” on page 54).

**Note:** A DIMM or DIMM filler must occupy each DIMM socket before the blade server is turned on.

Step 3. Touch the static-protective package that contains the DIMM to any *unpainted* metal surface on the BladeCenter unit or any *unpainted* metal surface on any other grounded rack component in the rack in which you are installing the DIMM for at least two seconds; then, remove the DIMM from its package.

Step 4. To install the DIMMs, repeat the following steps for each DIMM that you install:

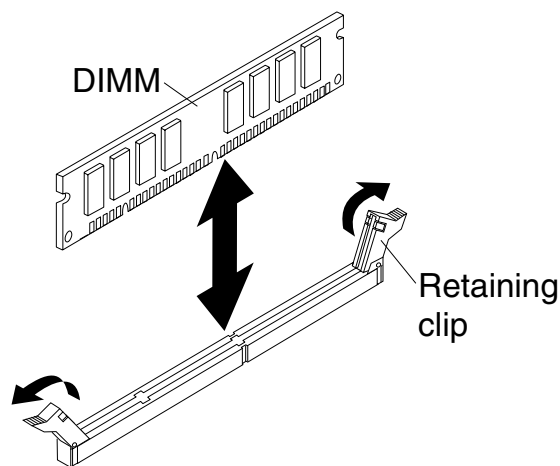

- Make sure that the retaining clips are in the open position, away from the center of the DIMM connector.
- Turn the DIMM so that the DIMM keys align correctly with the DIMM connector on the system board.

**Attention:** To avoid breaking the retaining clips or damaging the DIMM connectors, handle the clips gently.

- Press the DIMM into the DIMM connector. The retaining clips will lock the DIMM into the connector.
- Make sure that the small tabs on the retaining clips are in the notches on the DIMM. If there is a gap between the DIMM and the retaining clips, the DIMM has not been correctly installed. Press the DIMM firmly into the connector, and then press the retaining clips toward the DIMM

until the tabs are fully seated. When the DIMM is correctly installed, the retaining clips are parallel to the sides of the DIMM.

- Step 5. If the DIMM access door is open, use your fingers to close it.
- Step 6. Install the cover or the optional expansion unit onto the blade server (see “Installing the blade server cover” on page 44).
- Step 7. Install the blade server into the BladeCenter unit (see “Installing the blade server in a BladeCenter unit” on page 41).

## Removing a USB Flash key

Use this information to remove a USB Flash key from the blade server.

The following illustration shows the removal of a USB Flash key from the blade server.

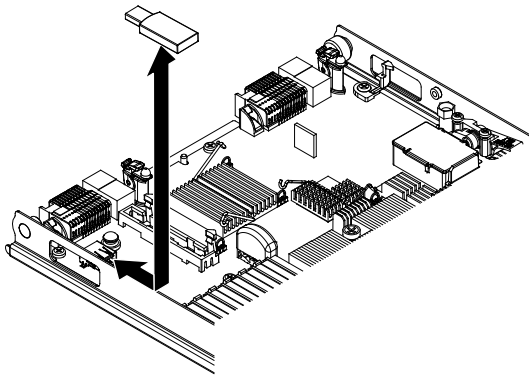

To remove the USB Flash key, complete the following steps.

- Step 1. Before you begin, read “Safety” on page v and “Installation guidelines” on page 39.
- Step 2. If the blade server is installed in a BladeCenter unit, remove it (see “Removing the blade server from the BladeCenter unit” on page 41).
- Step 3. Remove the blade server cover (see “Removing the blade server cover” on page 43).
- Step 4. If an optional expansion unit is installed, remove the expansion unit (see “Removing an optional expansion unit” on page 68).
- Step 5. Locate the USB Flash key on the system board (see “Blade server connectors” on page 7).
- Step 6. Using your fingers, pull the USB Flash key out of the connector.
- Step 7. If you are instructed to return the USB Flash key, follow all packaging instructions, and use any packaging materials for shipping that are supplied to you.

## Installing a USB Flash key

Use these instructions to install a USB Flash key in the blade server.

The following illustration shows the installation of the USB Flash key.

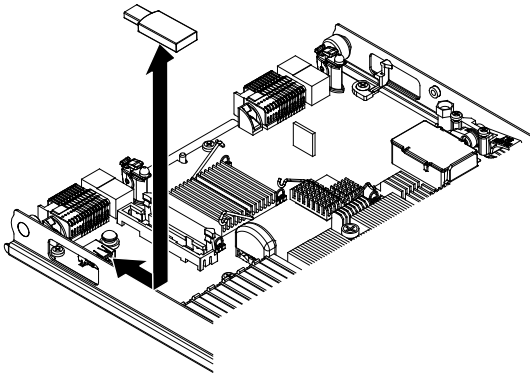

To install a USB module, complete the following steps:

- Step 1. If a CIOv expansion card is installed, remove the expansion card (see “Removing a CIOv-form-factor expansion card” on page 60).
- Step 2. Locate the USB connector on the blade server (see “Blade server connectors” on page 7).
- Step 3. Touch the static-protective package that contains the USB Flash key to any *unpainted* metal surface on the BladeCenter unit or any *unpainted* metal surface on any other grounded rack component in the rack in which you are installing the USB module for at least two seconds; then, remove the USB module from its package.
- Step 4. Orient the connector on the USB Flash key with the USB connector on the blade server.
- Step 5. Use your fingers to push the USB Flash key into the USB connector on the blade server.
- Step 6. If a CIOv expansion card was removed during the install process, install the expansion card (see “Installing a CIOv-form-factor expansion card” on page 62).
- Step 7. Install the cover or the optional expansion unit onto the blade server (see “Installing the blade server cover” on page 44).
- Step 8. Install the blade server into the BladeCenter unit (see “Installing the blade server in a BladeCenter unit” on page 41).

## Removing an I/O expansion card

The following sections describe how to remove the following expansion cards:

- vertical-combination-I/O (CIOv)
- horizontal-combination-form-factor (CFFh)

### Removing a CIOv-form-factor expansion card

Use these instructions to remove a CIOv-form-factor expansion card in the blade server.

The following illustration shows how to remove a vertical-combination-I/O (CIOv) expansion card.

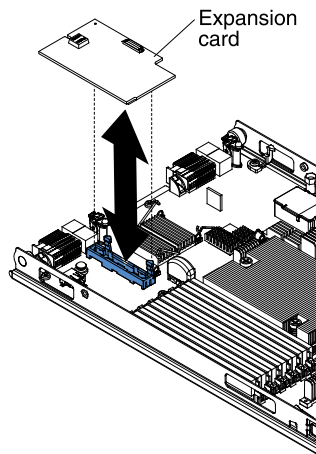

To remove a CIOv expansion card, complete the following steps:

- Step 1. Before you begin, read “Safety” on page v and “Installation guidelines” on page 39.
- Step 2. If the blade server is installed in a BladeCenter unit, remove it (see “Removing the blade server from the BladeCenter unit” on page 41 for instructions).
- Step 3. Carefully lay the blade server on a flat, static-protective surface.
- Step 4. Open the blade server cover (see “Removing the blade server cover” on page 43 for instructions).
- Step 5. Touch the static-protective package that contains the expansion card to any *unpainted* metal surface on the BladeCenter unit or any *unpainted* metal surface on any other grounded rack component; then, remove the expansion card from the package.
- Step 6. Locate the CIOv expansion connector (see “Blade server connectors” on page 7).

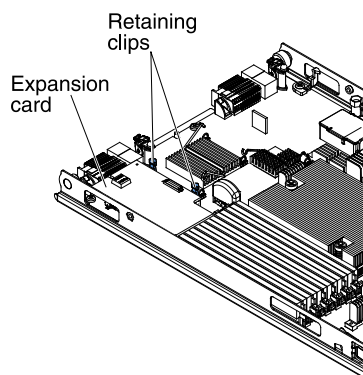

- Step 7. Using your fingers, move the retaining clips away from the CIOv card; then, lift the card out of the connector.

### Removing a horizontal-compact-form-factor expansion card

Use these instructions to remove a compact-form-factor expansion card from the blade server.

The following illustration shows how to remove a horizontal-compact-form-factor (CFFh) expansion card.

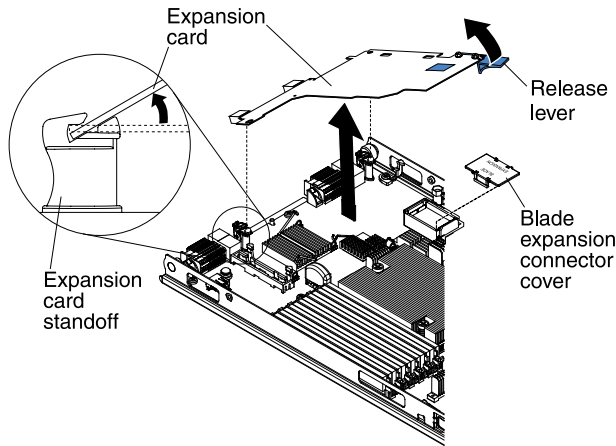

To remove a CFFh expansion card, complete the following steps:

- Step 1. Before you begin, read “Safety” on page v and “Installation guidelines” on page 39.
- Step 2. If the blade server is installed in a BladeCenter unit, remove it (see “Removing the blade server from the BladeCenter unit” on page 41 for instructions).
- Step 3. Carefully lay the blade server on a flat, static-protective surface.
- Step 4. Open the blade server cover (see “Removing the blade server cover” on page 43 for instructions).
- Step 5. Locate the CFFh expansion card. The CFFh expansion card is installed into the blade expansion connector (see “Blade server connectors” on page 7).
- Step 6. Open the expansion-card standoff.
- Step 7. Lift the release lever to disengage the CFFh expansion card from the expansion connector on the system board.
- Step 8. Use your fingers to hold the edge of the CFFh expansion card where it connects to the blade expansion connector; then, lift up on the card.

## Installing an I/O expansion card

The following sections describe how to install the following expansion cards:

- vertical-combination-I/O (CIOv)
- horizontal-combination-form-factor (CFFh)

### Installing a CIOv-form-factor expansion card

Use these instructions to install a CIOv-form-factor expansion card in the blade server.

The blade server supports a vertical-combination-I/O (CIOv) expansion card and a horizontal-combination-form-factor (CFFh) expansion card. The following illustration shows the location and installation of a CIOv expansion card.

**Attention:** If the expansion card is not running at the speed supported by the card, you can change the maximum speed of the PCIe bus in the Setup Utility by selecting **System Settings** and **Devices and I/O Ports**.



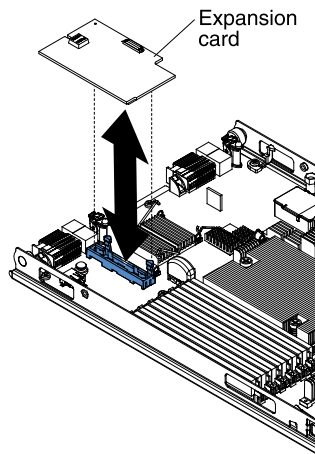

To install a CIOv expansion card, complete the following steps:

- Step 1. Touch the static-protective package that contains the expansion card to any *unpainted* metal surface on the BladeCenter unit or any *unpainted* metal surface on any other grounded rack component; then, remove the expansion card from the package.
- Step 2. Locate the CIOv expansion connector (see “Blade server connectors” on page 7).
- Step 3. Orient the connector on the expansion card with the CIOv expansion connector on the system board; then, press the card into the CIOv expansion connector.
- Step 4. Firmly press on the indicated locations to seat the expansion card.

**Note:** For device-driver and configuration information to complete the installation of the expansion card, see the documentation that comes with the expansion card.

- Step 5. Install the cover or the expansion unit onto the blade server (see “Installing the blade server cover” on page 44 or “Installing an optional expansion unit” on page 69).
- Step 6. Install the blade server into the BladeCenter unit (see “Installing the blade server in a BladeCenter unit” on page 41).

### Installing a horizontal-compact-form-factor expansion card

Use these instructions to install a compact-form-factor expansion card in the blade server.

The blade server supports a horizontal-combination-form-factor (CFFh) expansion card. The following illustration shows how to install a CFFh expansion card.

**Attention:** If the expansion card is not running at the speed supported by the card, you can change the maximum speed of the PCIe bus in the Setup Utility by selecting **System Settings** and **Devices and I/O Ports**.

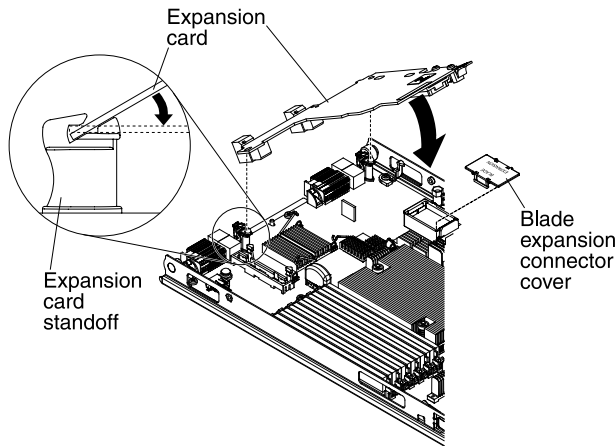

To install a CFFh expansion card, complete the following steps:

- Step 1. Locate the blade server expansion connector (see “Blade server connectors” on page 7).
- Step 2. If a cover is installed on the expansion connector, remove it by using your fingers to lift the cover from the expansion connector.
- Step 3. Touch the static-protective package that contains the expansion card to any *unpainted* metal surface on the BladeCenter unit or any *unpainted* metal surface on any other grounded rack component; then, remove the expansion card from the package.
- Step 4. Orient the connector on the expansion card and expansion connector on the system board; then, press the expansion card into the expansion connector.
- Step 5. Firmly press on the indicated locations to seat the expansion card.
 

**Note:** For device-driver and configuration information to complete the installation of the expansion card, see the documentation that comes with the expansion card.
- Step 6. Install the cover or the expansion unit onto the blade server (see “Installing the blade server cover” on page 44 or “Installing an optional expansion unit” on page 69).
- Step 7. Install the blade server into the BladeCenter unit (see “Installing the blade server in a BladeCenter unit” on page 41).

## Removing a storage interface card

Use this information to remove a storage interface card from the blade server.

The storage interface card controls the hot-swap storage drives. The following illustrations show how to remove a ServeRAID H1135 CIOv storage interface card from the blade server. The illustrations and removal instructions are similar for other CIOv storage interface cards.

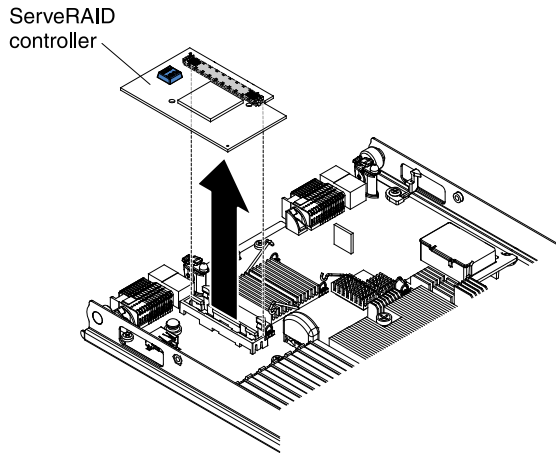

To remove a storage interface card, complete the following steps:

- Step 1. Before you begin, read “Safety” on page v and “Installation guidelines” on page 39.
- Step 2. If the blade server is installed in a BladeCenter unit, remove it (see “Removing the blade server from the BladeCenter unit” on page 41 for instructions).
- Step 3. Remove the blade server cover (see “Removing the blade server cover” on page 43 for instructions).
- Step 4. If an optional expansion unit is installed, remove the expansion unit (see “Removing an optional expansion unit” on page 68).
- Step 5. Locate the storage interface card installed in the CIOv connector on the system board (see “Blade server connectors” on page 7).

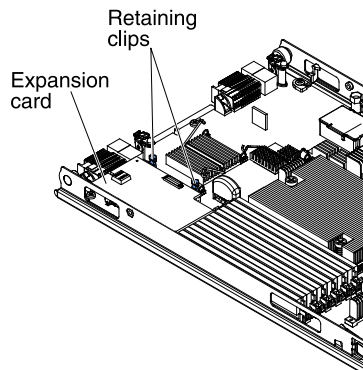

- Step 6. Gently push the retaining clips away from the expansion card; then, lift the card out of the expansion-card connector.
- Step 7. If you are instructed to return the storage interface card, follow all packaging instructions, and use any packaging materials for shipping that are supplied to you.

## Installing a storage interface card

Use this information to install a storage interface card in the blade server.

For more information about the ServeRAID H1135, see the *Installation and User's Guide for ServeRAID H1135* at <http://www-947.ibm.com/support/entry/portal/docdisplay?brand=5000008&Indocid=MIGR-5088601>.

The storage interface card controls the SAS/SATA hot-swap storage drives. The following illustrations and installation instructions show how to install a ServeRAID H1135 controller into the CIOv expansion connector

of the blade server. The illustrations and installation instructions are similar for other CIOv storage interface cards.

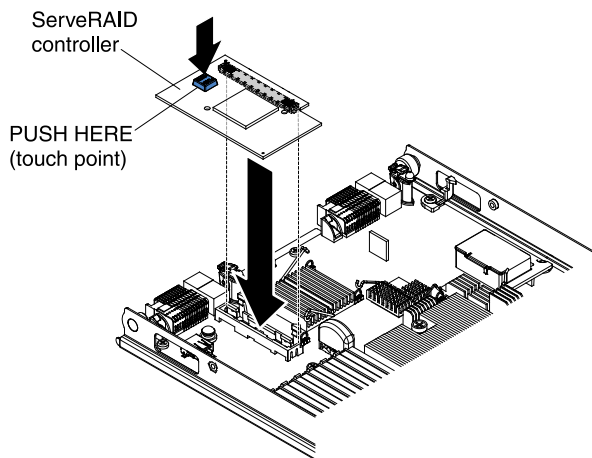

To install a storage interface card, complete the following steps:

- Step 1. Locate the CIOv expansion connector (see “Blade server connectors” on page 7).
- Step 2. Touch the static-protective package that contains the storage interface card to any *unpainted* metal surface on the BladeCenter unit or any *unpainted* metal surface on any other grounded rack component; then, remove the storage interface card from the package.
- Step 3. Orient the connector on the storage interface card with the CIOv expansion connector on the system board; then, press the storage interface card into the CIOv expansion connector.
- Step 4. Firmly press on the indicated locations to seat the storage interface card.  
**Note:** For device-driver and configuration information to complete the installation of the expansion card, see the documentation that comes with the storage interface card.
- Step 5. Install the cover or the optional expansion unit onto the blade server (see “Installing the blade server cover” on page 44).
- Step 6. Install the blade server into the BladeCenter unit (see “Installing the blade server in a BladeCenter unit” on page 41).

## Removing the control panel

Use this information to remove the control panel from the blade server.

1. The following illustration shows the locations of the control panel on the system board.
2. The illustrations in this document might differ slightly from your hardware.

To remove the control panel, complete the following steps.

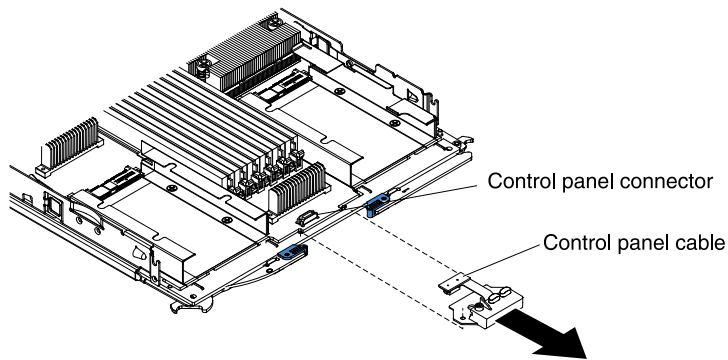

- Step 1. Before you begin, read “Safety” on page v and “Installation guidelines” on page 39.
- Step 2. If the blade server is installed in a BladeCenter unit, remove it (see “Removing the blade server from the BladeCenter unit” on page 41).
- Step 3. Remove the blade server cover (see “Installing the blade server cover” on page 44).
- Step 4. If an optional expansion unit is installed, remove the expansion unit (see “Removing an optional expansion unit” on page 68).
- Step 5. Remove the bezel assembly (see “Removing the bezel assembly” on page 45).
- Step 6. Locate the control-panel connector on the system board (see “Blade server connectors” on page 7).
- Step 7. Using your fingers, pull the control-panel cable out of the connector; then lift the control panel from the blade server.
- Step 8. If you are instructed to return the control panel, follow all packaging instructions, and use any packaging materials for shipping that are supplied to you.

## Installing the control panel

Use these instructions to install the control panel in the blade server.

The blade server has a control panel that provides controls and information LEDs for the blade server (see “Blade server controls and LEDs” on page 3). The following illustration shows how to install the control panel.

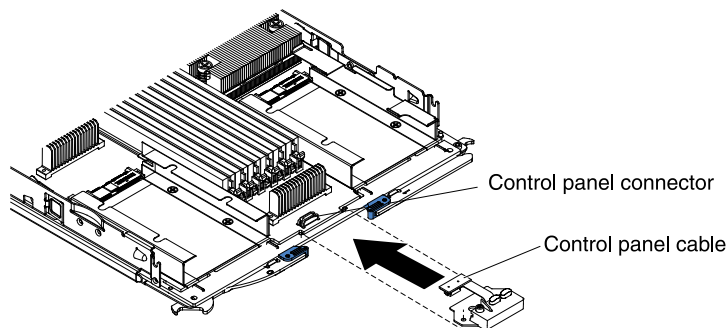

To install the control panel, complete the following steps:

- Step 1. Locate the control-panel connector on the blade server (see “Blade server connectors” on page 7).
- Step 2. Touch the static-protective package that contains the control panel to any *unpainted* metal surface on the BladeCenter unit or any *unpainted* metal surface on any other grounded rack component in the rack in which you are installing the control panel for at least two seconds; then, remove the USB module from its package.

- Step 3. Orient the control panel so the cable aligns with the control-panel connector and the control panel is positioned at the front of the blade server.
- Step 4. Use your fingers to install the control-panel cable into the control-panel connector on the blade server.
- Step 5. Install the bezel assembly (see “Installing the bezel assembly” on page 46).
- Step 6. Install the optional expansion unit, if you removed one from the blade server to replace the battery (see “Installing an optional expansion unit” on page 69 for instructions).
- Step 7. Install the cover onto the blade server (see “Installing the blade server cover” on page 44).
- Step 8. Install the blade server into the BladeCenter unit (see “Installing the blade server in a BladeCenter unit” on page 41).

## Removing an optional expansion unit

Use these instructions to remove the optional expansion unit from the blade server.

To remove an optional expansion unit, complete the following steps:

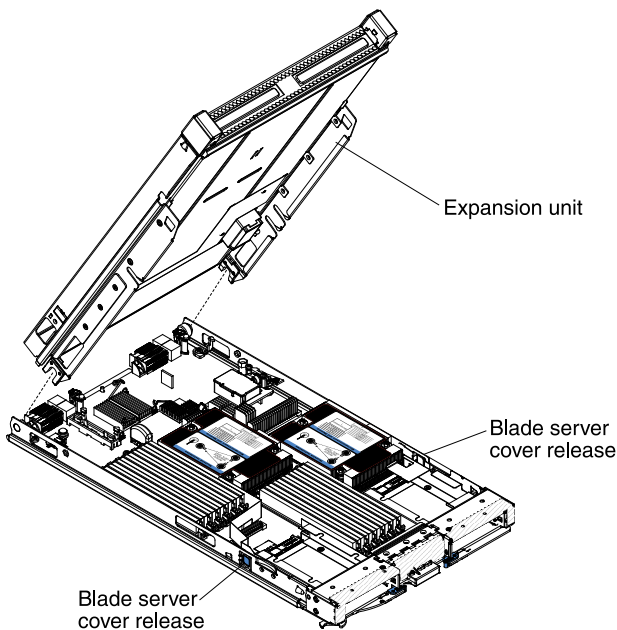

- Step 1. Before you begin, read “Safety” on page v and “Installation guidelines” on page 39.
- Step 2. If the blade server is installed in a BladeCenter unit, remove it (see “Removing the blade server from the BladeCenter unit” on page 41 for instructions).
- Step 3. Carefully lay the blade server on a flat, static-protective surface, with the cover side up.
- Step 4. Remove the blade server cover, if one is installed (see “Removing the blade server cover” on page 43 for instructions).
- Step 5. Remove the expansion unit:
  - a. If the expansion unit has an extraction device, use the extraction device to disengage the expansion unit from the blade server. These extraction devices can be of several types, including thumbscrews or levers. See the instructions provided with the expansion unit for detailed instructions for removing the expansion unit.
  - b. If the expansion unit does not have an extraction device, press the blade server cover release on each side of the blade server and lift the expansion unit from the blade server.

c. Rotate the expansion unit open; then, lift the expansion unit from the blade server.

Step 6. If you are instructed to return the expansion unit, remove from it any options that you have installed; then, follow all packaging instructions, and use any packaging materials for shipping that are supplied to you.

## Installing an optional expansion unit

Use these instructions to install an optional expansion unit.

**Attention:** If a horizontal combination-form-factor (CFFh) expansion card is installed on the blade server system board, you cannot install an optional expansion unit.

### Notes:

1. All devices should be installed in an expansion unit before attaching it to the blade server.
2. After you install one or more expansion units on your blade server, the combined blade server and expansion units together occupy adjacent blade bays in the BladeCenter unit. Enough power modules must be installed in the BladeCenter unit to power the blade bays in which you install the blade server and expansion units.
3. The following illustration shows an optional expansion unit in a blade server.
4. The illustrations in this document might differ slightly from your hardware.

To install an optional expansion unit, complete the following steps.

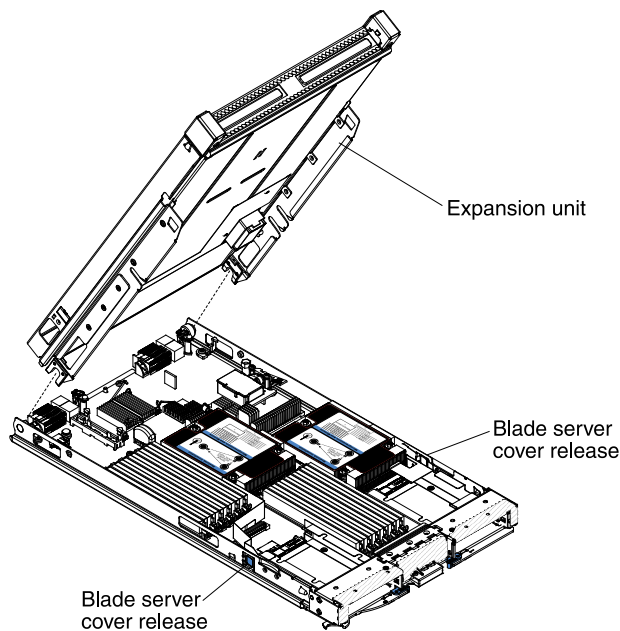

- Step 1. Locate the blade expansion connector on the blade server system board or the expansion unit and remove the cover if one is installed (see “Blade server connectors” on page 7).
- Step 2. Touch the static-protective package that contains the optional expansion unit to any *unpainted* metal surface on the BladeCenter unit or any *unpainted* metal surface on any other grounded rack component; then, remove the optional expansion unit from the package.
- Step 3. Orient the optional expansion unit as shown in the illustration.
- Step 4. Lower the expansion unit so that the slots at the rear slide down onto the cover pins at the rear of the blade server; then, pivot the expansion unit down onto the blade server.

- Step 5. If the expansion unit has an extraction device (such as a thumbscrew or a lever), use it to fully engage the expansion unit on the blade server; otherwise, press the expansion unit firmly into the closed position until it clicks into place. To install an option into the expansion unit, refer to the documentation provided with the expansion unit.
- Step 6. If additional expansion units are being installed, repeat steps 4 through 8 for each expansion blade; otherwise continue with step 11.
- Step 7. Follow the instructions provided with the expansion unit to install an option in the expansion unit.
- Step 8. If this is the last expansion blade being installed, install the cover provided with the expansion unit (see “Installing the blade server cover” on page 44).
- Step 9. Install the blade server into the BladeCenter unit (see “Installing the blade server in a BladeCenter unit” on page 41).

---

## Removing and replacing Tier 2 CRUs

Use this information to determine the guidelines for installing a Tier 2 CRU into your blade server.

You may install a Tier 2 CRU yourself or request IBM to install it, at no additional charge, under the type of warranty service that is designated for the server.

Some Tier 2 CRUs are available as both optional devices and replaceable components. You can use the installation instructions for the Tier 2 CRU to install the optional device.

The illustrations in this document might differ slightly from your hardware.

## Removing a microprocessor and heat sink

Use this information to remove a microprocessor and heat sink from the blade server. The microprocessor and heat sink assembly must be replaced by a trained technician.

Read the following important guidelines before you remove a microprocessor that is not faulty (for example, when you are replacing the system-board assembly).

If you are not replacing a defective heat sink or microprocessor, the thermal grease on the heat sink and microprocessor will remain effective if you carefully handle the heat sink and microprocessor when you remove or install these components. Do not touch the thermal grease or otherwise allow it to become contaminated.

### Notes:

1. Read the following important information before you remove a microprocessor that is not faulty (for example, when you are replacing the system-board assembly).

If you are not replacing a defective heat sink or microprocessor, the thermal grease on the heat sink and microprocessor will remain effective if you carefully handle the heat sink and microprocessor when you remove or install these components. Do not touch the thermal grease or otherwise allow it to become contaminated.
2. The microprocessor installation tool might become worn after several uses. Make sure that the tool can hold the microprocessor securely if you are reusing an existing microprocessor installation tool. Do not return the tool with other parts that you are returning.
3. Do not touch the contacts in the microprocessor socket. Touching these contacts might result in permanent damage to the system board.
4. Microprocessors are to be removed only by trained technicians.



**Important:** Always use the microprocessor installation tool to remove a microprocessor. Failing to use the microprocessor installation tool may damage the microprocessor sockets on the system board. Any damage to the microprocessor sockets may require replacing the system board.

To remove a microprocessor, complete the following steps:

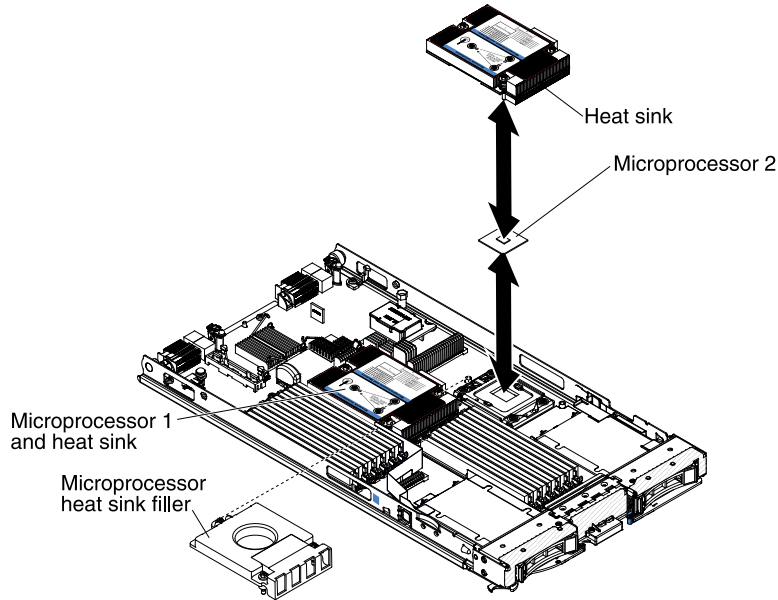

- Step 1. Before you begin, read “Safety” on page v and “Installation guidelines” on page 39.
- Step 2. If the blade server is installed in a BladeCenter unit, remove it (see “Removing the blade server from the BladeCenter unit” on page 41 for instructions).
- Step 3. Remove the blade server cover (see “Removing the blade server cover” on page 43 for instructions).
- Step 4. If an optional expansion unit is installed, remove the expansion unit (see “Removing an optional expansion unit” on page 68).
- Step 5. Locate the microprocessor that will be removed (see “Blade server connectors” on page 7).
- Step 6. Remove the heat sink.

**Attention:** Do not touch the thermal grease on the bottom of the heat sink. Touching the thermal grease will contaminate it. If the thermal grease on the microprocessor or heat sink becomes contaminated, wipe off the contaminated thermal grease on the microprocessor or heat sink with the alcohol wipes and reapply clean thermal grease to the heat sink.

- a. Loosen the screw on one side of the heat sink to break the seal with the microprocessor.
- b. Use a screwdriver to loosen the screws on the heat sink, rotating each screw two full turns until each screw is loose.
- c. Use your fingers to gently pull the heat sink from the microprocessor.

**Attention:** Do not use any tools or sharp objects to lift the release levers on the microprocessor socket. Doing so might result in permanent damage to the system board.

- Step 7. Open the microprocessor socket release levers and retainer.

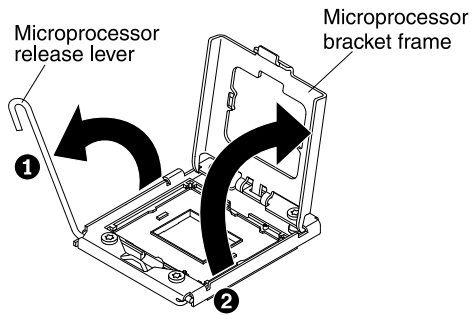

- a. Open the release lever on the microprocessor socket.
- b. Open the microprocessor retainer.

**Note:** Do not touch the microprocessor contacts. Contaminants on the microprocessor contacts, such as oil from your skin, can cause connection failures between the contacts and the socket.

Step 8. Install the microprocessor on the microprocessor installation tool:

**Note:** If you are replacing a microprocessor, use the empty installation tool that comes with the new microprocessor to remove the microprocessor.

- a. Twist the handle on the microprocessor tool counterclockwise so that it is in the open position.

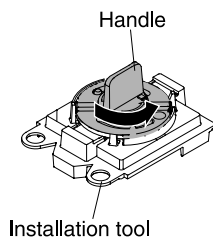

- b. Align the installation tool with the alignment pins on the microprocessor socket and lower the tool on the microprocessor. The installation tool rests flush on the socket only if aligned correctly.

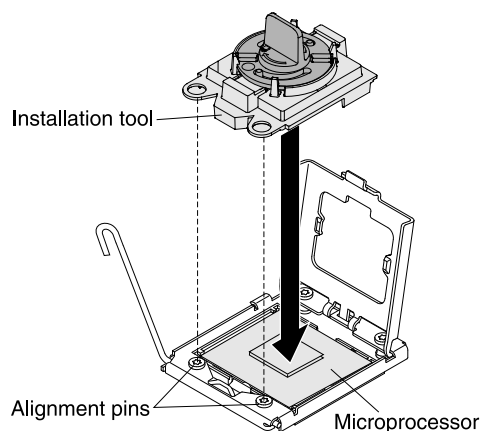

- c. Twist the handle on the installation tool clockwise.

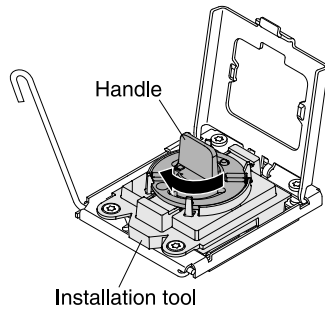

- d. Lift the microprocessor out of the socket.

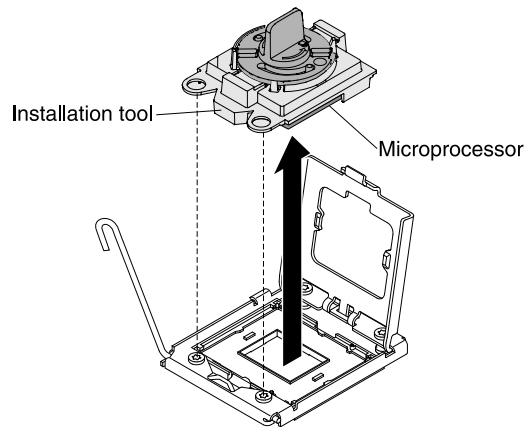

Step 9. If you do not intend to install a microprocessor on the socket, install the socket cover that you removed before on the microprocessor socket.

**Note:** The pins on the socket are fragile. Any damage to the pins may require replacing the system board.

Step 10. If you are instructed to return the microprocessor and heat sink, follow all packaging instructions, and use any packaging materials for shipping that are supplied to you.

## Installing a microprocessor and heat sink

Use this information to install a microprocessor and heat sink in the blade server.

The following notes describe the type of microprocessor that the server supports and other information that you must consider when you install a microprocessor:

- Microprocessors are to be installed only by trained technicians. **Important:** Always use the microprocessor installation tool to install a microprocessor. Failing to use the microprocessor installation tool may damage the microprocessor sockets on the system board. Any damage to the microprocessor sockets may require replacing the system board.
- Each microprocessor socket must always contain either a socket cover and heat-sink filler or a microprocessor and heat sink. If the blade server has only one microprocessor, it must be installed in microprocessor socket 1.
- If you are installing a second microprocessor, make sure that the microprocessors are identical in core speed, QPI, cache size, core quantity, and power segment. The system might hang, if the installed microprocessors are mismatched.
- Before you install a new microprocessor, download and install the most current level of UEFI code (see “Updating firmware and device drivers” on page 23).

- When you install a second microprocessor, you might have to install additional memory, or redistribute memory across the DIMM connectors (see “Installing a memory module” on page 55).
- The microprocessor installation tool might become worn after several uses. Make sure that the tool can hold the microprocessor securely if you are reusing an existing microprocessor installation tool. Do not return the tool with other parts that you are returning.
- The server supports only one microprocessor when the certain microprocessor is installed in microprocessor socket 1. For example, microprocessor Intel Pentium 1403, Intel Pentium 1407, or Intel Xeon E5-1410. The following illustration attached on the microprocessor socket 2 filler shows that microprocessor socket 2 is not supported.

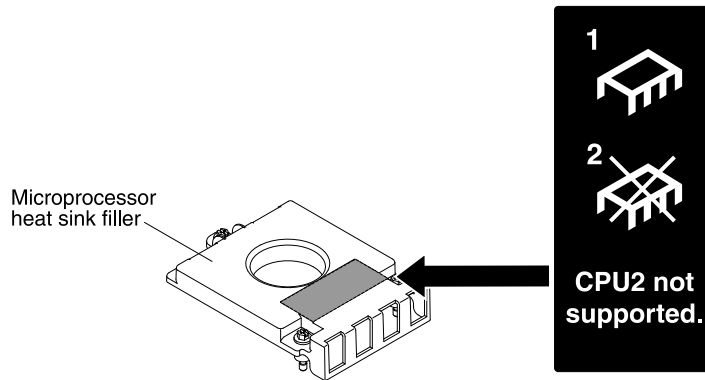

The following illustration shows how to install a microprocessor and heat sink in the blade server.

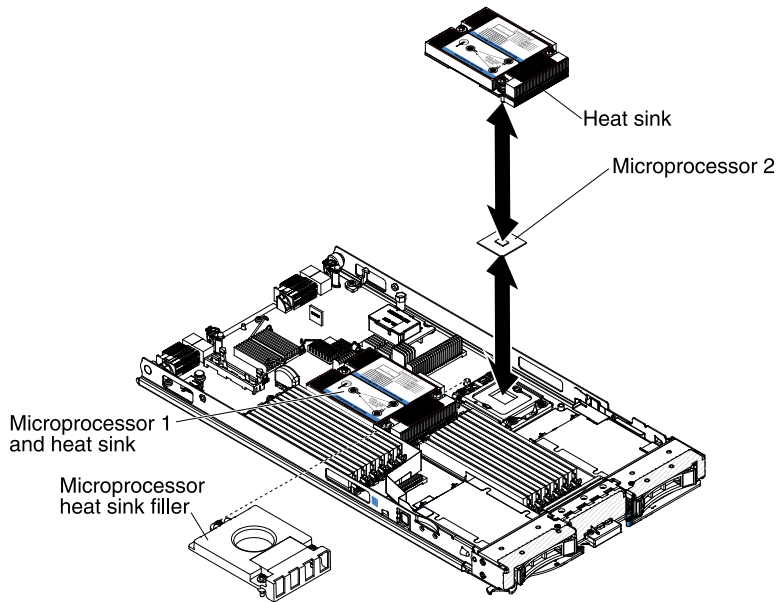

**Attention:**

1. Do not use any tools or sharp objects to lift the release levers on the microprocessor socket. Doing so might result in permanent damage to the system board.
2. Do not touch the contacts in the microprocessor socket. Touching these contacts might result in permanent damage to the system board.

To install a microprocessor and heat sink, complete the following steps:

- Step 1. Remove the heat-sink filler, if one is present.
- Step 2. If you are not installing a new microprocessor and a new heat sink, remove the thermal grease from the heat sink and microprocessor; then, apply new thermal grease before installation (see “Thermal grease” on page 77).

**Attention:** Do not use any tools or sharp objects to lift the release levers on the microprocessor socket. Doing so might result in permanent damage to the system board.

- Step 3. Open the microprocessor socket release lever and retainer:

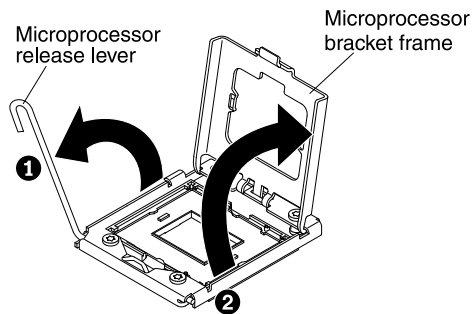

- a. Open the release lever on the microprocessor socket.
- b. Open the microprocessor retainer.

**Attention:** Do not touch the connectors on the microprocessor and the microprocessor socket.

- Step 4. Install the microprocessor in the microprocessor socket:

- a. Touch the static-protective bag that contains the new microprocessor to any *unpainted* surface on the BladeCenter chassis or any *unpainted* metal surface on any other grounded rack component; then, carefully remove the microprocessor and the installation tool from the package.
- b. The microprocessor is preinstalled on the installation tool. Release the sides of the cover and remove the cover from the installation tool.

**Note:** Do not touch the microprocessor contacts. Contaminants on the microprocessor contacts, such as oil from your skin, can cause connection failures between the contacts and the socket.

- c. Align the installation tool with the microprocessor socket. The installation tool rests flush on the socket only if properly aligned.

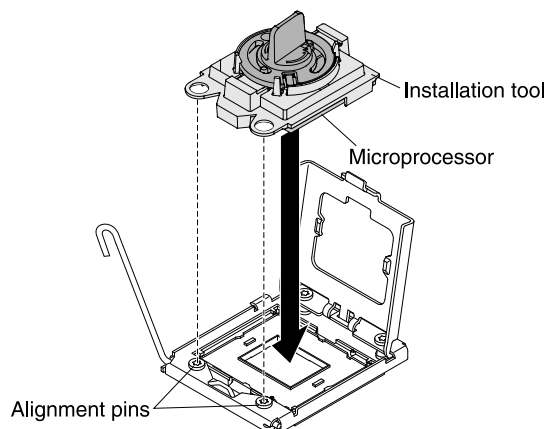

- d. Twist the handle on the microprocessor tool counterclockwise to insert the microprocessor into the socket. The microprocessor is keyed to ensure that the microprocessor is installed correctly. The microprocessor rests flush on the socket only if properly installed.

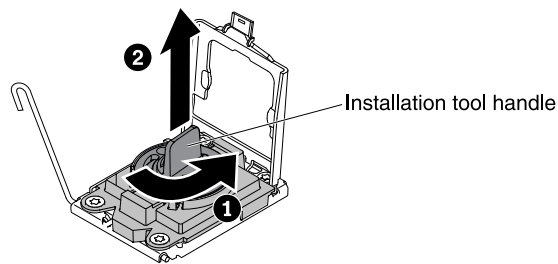

**Attention:**

- Do not press the microprocessor into the socket.
- Do not touch exposed pins of the microprocessor socket.
- Make sure that the microprocessor is oriented and aligned correctly in the socket before you try to close the microprocessor retainer.
- Do not touch the thermal grease on the bottom of the heat sink or on top of the microprocessor. Touching the thermal grease will contaminate it.

- Step 5. Remove the socket cover, if one is present. Keep the socket cover in a safe place for potential future use.

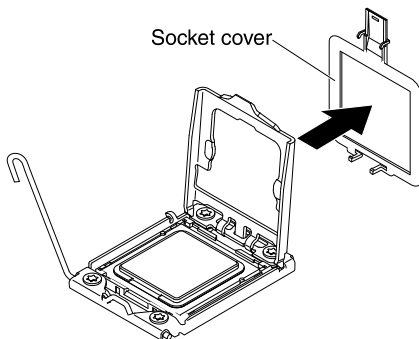

- Step 6. Close the microprocessor socket release lever and retainer:

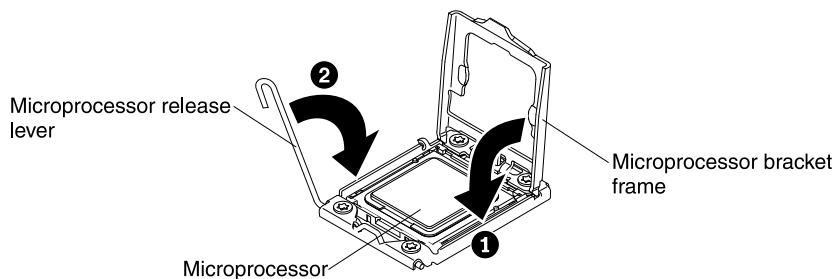

- a. Close the microprocessor retainer on the microprocessor socket.
- b. Close the release lever on the microprocessor socket.

- Step 7. If you are reinstalling a heat sink that was removed from the blade server, complete the following steps.

**Attention:** Do not touch the thermal grease on the bottom of the heat sink. Touching the thermal grease will contaminate it. If the thermal grease on the microprocessor or heat sink becomes contaminated, wipe off the contaminated thermal grease on the microprocessor or heat sink with the alcohol wipes and reapply clean thermal grease to the heat sink (see “Thermal grease” on page 77).

- a. Make sure that the thermal grease is still on the bottom of the heat sink and on the top of the microprocessor.
- b. Position the heat sink over the microprocessor. The heat sink is keyed to assist with proper alignment.
- c. Align and place the heat sink on top of the microprocessor in the retention bracket, thermal grease side down. Press firmly on the heat sink.
- d. Align the screws on the heat sink with the holes on the heat-sink retention module.
- e. Press firmly on the captive screws and tighten them with a screwdriver, alternating among the screws until they are tight. If possible, each screw should be rotated two full rotations at a time. Repeat until the screws are tight. Do not overtighten the screws by using excessive force. If you are using a torque wrench, tighten the screws to 8.5 Newton-meters (Nm) to 13 Nm (6.3 foot-pounds to 9.6 foot-pounds).

Step 8. If you are installing a new heat sink, complete the following steps.

**Attention:**

- Do not set down the heat sink after you remove the plastic cover.
  - Do not touch the thermal grease on the bottom of the heat sink. Touching the thermal grease will contaminate it. If the thermal grease on the microprocessor or heat sink becomes contaminated, wipe off the contaminated thermal grease on the microprocessor or heat sink with the alcohol wipes and reapply clean thermal grease to the heat sink (see “Thermal grease” on page 77).
- a. Remove the plastic protective cover from the bottom of the heat sink.
  - b. Position the heat sink over the microprocessor. The heat sink is keyed to assist with proper alignment.
  - c. Align and place the heat sink on top of the microprocessor in the retention bracket, thermal grease side down.
  - d. Press firmly on the heat sink.
  - e. Align the screws on the heat sink with the holes on the heat-sink retention module.
  - f. Press firmly on the captive screws and tighten them with a screwdriver, alternating among the screws until they are tight. If possible, each screw should be rotated two full rotations at a time. Repeat until the screws are tight. Do not overtighten the screws by using excessive force. If you are using a torque wrench, tighten the screws to 8.5 Newton-meters (Nm) to 13 Nm (6.3 foot-pounds to 9.6 foot-pounds).

Step 9. If you are not installing a new microprocessor and a new heat sink, remove the thermal grease from the heat sink and microprocessor; then, apply new thermal grease before installation (see “Thermal grease” on page 77).

Step 10. Install the optional expansion unit, if you removed one from the blade server to replace the battery (see “Installing an optional expansion unit” on page 69 for instructions).

Step 11. Install the cover onto the blade server (see “Installing the blade server cover” on page 44).

Step 12. Install the blade server into the BladeCenter unit (see “Installing the blade server in a BladeCenter unit” on page 41).

## Thermal grease

Use this information to determine the guidelines for using thermal grease on a heat sink and processor.

The thermal grease must be replaced whenever the heat sink has been removed from the top of the microprocessor and is going to be reused or when debris is found in the grease.

To replace damaged or contaminated thermal grease on the microprocessor and heat sink, complete the following steps:

- Step 1. Place the heat-sink assembly on a clean work surface.
- Step 2. Remove the cleaning pad from its package and unfold it completely.
- Step 3. Use the cleaning pad to wipe the thermal grease from the bottom of the heat sink.

**Note:** Make sure that all of the thermal grease is removed.

- Step 4. Use a clean area of the cleaning pad to wipe the thermal grease from the microprocessor; then, dispose of the cleaning pad after all of the thermal grease is removed.

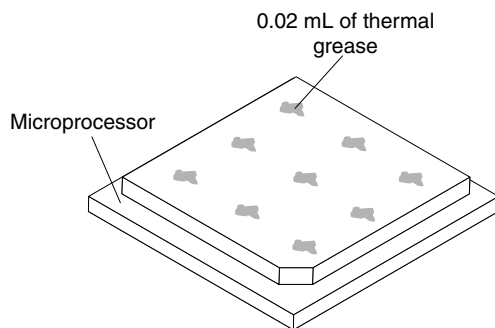

- Step 5. Use the thermal-grease syringe to place nine uniformly spaced dots of 0.02 mL each on the top of the microprocessor.

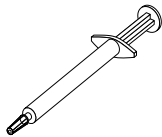

**Note:** 0.01 mL is one tick mark on the syringe. If the grease is properly applied, approximately half (0.22 mL) of the grease will remain in the syringe.

- Step 6. Continue with step “Installing a microprocessor and heat sink” on page 73.

## Removing the system-board assembly

Use this information to remove the system-board assembly from the blade server.

When you replace the system board, you will replace the system board and blade base as one assembly. After replacement, you must either update the blade server with the latest firmware or restore the pre-existing firmware that the customer provides on a diskette or CD image.

**Note:** See “Blade server system-board layouts” on page 7 for more information on the locations of the connectors, jumpers and LEDs on the system board.

To remove the system-board assembly, complete the following steps:

- Step 1. Before you begin, read “Safety” on page v, “Handling static-sensitive devices” on page 40, and “Installation guidelines” on page 39.
- Step 2. If the blade server is installed in a BladeCenter unit, remove it (see “Removing the blade server from the BladeCenter unit” on page 41 for instructions).



- Step 3. Carefully lay the blade server on a flat, static-protective surface.
- Step 4. Remove the blade server cover (see “Removing the blade server cover” on page 43).
- Step 5. If an optional expansion unit is installed, remove the expansion unit (see “Removing an optional expansion unit” on page 68).
- Step 6. Remove all of the installed components in the following list from the system-board assembly; then, place them on a static-protective surface or install them on the new system-board assembly.
- DIMMs. See “Removing a memory module” on page 54.
  - USB module. See “Removing a USB Flash key” on page 59.
  - I/O expansion cards. See “Removing a CIOv-form-factor expansion card” on page 60, “Removing a horizontal-compact-form-factor expansion card” on page 61, and “Removing a storage interface card” on page 64.
  - Storage drives. See “Removing a hot-swap storage drive” on page 53.
  - Microprocessors and heat sinks. See “Removing a microprocessor and heat sink” on page 70.
- Step 7. The new system-board assembly comes with an IBM Repair Identification (RID) tag. Using a ball point pen, transfer the machine type and serial number from the old system-board assembly to the two labels on the IBM Repair Identification (RID) tag provided with the new system-board assembly; then, place label 1 (larger label) on the base of the system board and label 2 (smaller label) on the bottom side of the control panel.

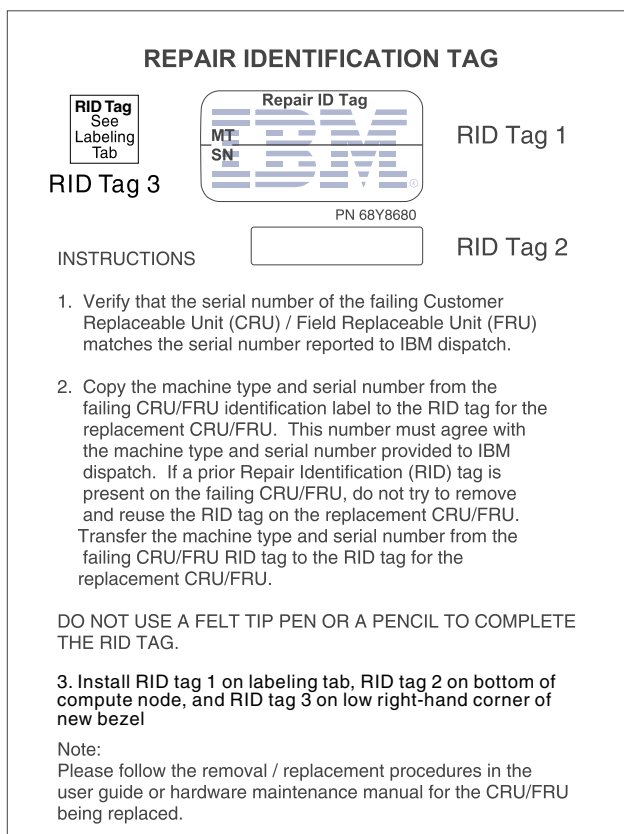

- Step 8. If you are instructed to return the system-board assembly, follow all packaging instructions, and use any packaging materials for shipping that are supplied to you.

## Installing the system-board assembly

Use this information to install the system-board assembly in the blade server.

**Important:** When you replace the system board, you must either update the server with the latest firmware or restore the pre-existing firmware that the customer provides on a diskette or CD image. Make sure that you have the latest firmware or a copy of the pre-existing firmware before you proceed. See “Updating the DMI/SMBIOS data” on page 18 and “Updating firmware and device drivers” on page 23 for more information.

To install the system-board assembly, complete the following steps:

Step 1. Using a ball point pen, transfer the machine type and serial number from the old system-board assembly to the two labels on the IBM Repair Identification (RID) tag provided with the new system-board assembly; then, place label 1 (larger label) on the base of the system board and label 2 (smaller label) on the bottom side of the control panel.

**REPAIR IDENTIFICATION TAG**



RID Tag 3



RID Tag 1

PN 68Y8680

INSTRUCTIONS

RID Tag 2

1. Verify that the serial number of the failing Customer Replaceable Unit (CRU) / Field Replaceable Unit (FRU) matches the serial number reported to IBM dispatch.
2. Copy the machine type and serial number from the failing CRU/FRU identification label to the RID tag for the replacement CRU/FRU. This number must agree with the machine type and serial number provided to IBM dispatch. If a prior Repair Identification (RID) tag is present on the failing CRU/FRU, do not try to remove and reuse the RID tag on the replacement CRU/FRU. Transfer the machine type and serial number from the failing CRU/FRU RID tag to the RID tag for the replacement CRU/FRU.

DO NOT USE A FELT TIP PEN OR A PENCIL TO COMPLETE THE RID TAG.

3. Install RID tag 1 on labeling tab, RID tag 2 on bottom of compute node, and RID tag 3 on low right-hand corner of new bezel

Note:  
Please follow the removal / replacement procedures in the user guide or hardware maintenance manual for the CRU/FRU being replaced.

Step 2. Install all of the components in the following list that you removed from the old system-board assembly onto the new system-board assembly.

- DIMMs. See “Installing a memory module” on page 55.
- USB module. See “Installing a USB Flash key” on page 59.
- I/O expansion cards. See “Installing a CIOv-form-factor expansion card” on page 62, “Installing a horizontal-compact-form-factor expansion card” on page 63, and “Installing a storage interface card” on page 65.
- Storage drives. See “Installing a hot-swap storage drive” on page 53.
- Microprocessors and heat sinks. See “Installing a microprocessor and heat sink” on page 73.

Step 3. Install the optional expansion unit, if you removed one from the blade server to replace the battery (see “Installing an optional expansion unit” on page 69 for instructions).

Step 4. Install the cover onto the blade server (see “Installing the blade server cover” on page 44).

80 BladeCenter HS23E Blade Server Problem Determination and Service Guide

- Step 5. Install the blade server into the BladeCenter unit (see “Installing the blade server in a BladeCenter unit” on page 41).
- Step 6. The Universal Unique Identifier (UUID) must be updated when the system board is replaced. Use the Advanced Settings Utility to update the UUID in the UEFI-based server (see “Updating the Universal Unique Identifier (UUID)” on page 16).
- Step 7. Update the server with the latest firmware or restore the pre-existing firmware that the customer provides on a diskette or CD image. Make sure that you have the latest firmware or a copy of the pre-existing firmware before you proceed. See “Updating the DMI/SMBIOS data” on page 18 and “Updating firmware and device drivers” on page 23 for more information.



---

## Chapter 5. Diagnostics

Use this information to review the diagnostic tools that are available to help you solve problems that might occur in the blade server.

Review the diagnostic tools that are available to help you solve problems that might occur in the blade server.

**Note:** The blade server uses shared resources that are installed in the BladeCenter unit. Problems with these shared resources might appear to be in the blade server (see “Solving shared BladeCenter resource problems” on page 196 for information about isolating problems with these resources).

If you cannot locate and correct a problem by using the information in this chapter, see Appendix A “Getting help and technical assistance” on page 203 for more information.

---

### Service bulletins

IBM updates the support website with tips and techniques that you can use to solve any problems that you might be having with the BladeCenter HS23E blade server.

To find any service bulletins that are available for the BladeCenter HS23Eblade server, go to the BladeCenter support website at <http://www.ibm.com/supportportal/>. In the **Search** field, enter the following terms: 8038, 8039, and retain tip.

---

### Checkout procedure

Use this information to perform the checkout procedure for the blade server.

The checkout procedure is the sequence of tasks that you should follow to diagnose a problem in the blade server.

### About the checkout procedure

Use this information to run diagnostics, locate error codes, and identify device errors for the blade server.

Before you perform the checkout procedure for diagnosing hardware problems, review the following information:

- Read “Safety” on page v and “Installation guidelines” on page 39.
- The diagnostic programs provide the primary methods of testing the major components of the blade server. If you are not sure whether a problem is caused by the hardware or by the software, you can use the diagnostic programs to confirm that the hardware is working correctly.
- When you run the diagnostic programs, a single problem might cause more than one error message. When this happens, correct the cause of the first error message. The other error messages usually will not occur the next time you run the diagnostic programs.
- If the blade server is halted and a POST error code is displayed, see “UEFI/POST error codes” on page 88. If the blade server is halted and no error message is displayed, see “Troubleshooting tables” on page 150 and “Solving undetermined problems” on page 200.
- For intermittent problems, check the error log; see “Event logs” on page 85 and “IBM Dynamic System Analysis Preboot diagnostic program” on page 170.
- If no LEDs are lit on the blade server front panel, verify the blade server status and errors in the Advanced-Management-Module Web interface; also see “Solving undetermined problems” on page 200.

- If device errors occur, see “Troubleshooting tables” on page 150.

## Performing the checkout procedure

Use this information to perform the checkout procedure for the blade server.

To perform the checkout procedure, complete the following steps:

- Step 1. If the blade server is running, turn off the blade server.
- Step 2. Turn on the blade server. Make sure that the blade server has control of the video (the LED on the keyboard/video/mouse button is lit). If the blade server does not start, see “Troubleshooting tables” on page 150.
- Step 3. Record any POST error messages that are displayed on the monitor. If an error is displayed, look up the first error in the “UEFI/POST error codes” on page 88.
- Step 4. Check the control panel blade-error LED; if it is lit, check the light path diagnostics LEDs (see “Light path diagnostics” on page 164).
- Step 5. Check for the following results:
  - Successful completion of POST, indicated by beginning the startup of the operating system.
  - Successful completion of startup, indicated by a readable display of the operating-system desktop.

---

## Diagnostic tools overview

Use this overview to locate specific diagnostic tools to diagnose and solve hardware-related problems.

The following tools are available to help you diagnose and solve hardware-related problems:

- **POST codes, error messages, and error logs**

The POST error codes indicate the detection of a problem. For more information, see “POST” on page 85.

- **Troubleshooting tables**

These tables list problem symptoms and actions to correct the problems. See “Troubleshooting tables” on page 150

- **Light path diagnostics**

Use light path diagnostics LEDs on the system board to diagnose system errors. If the system-error LED on the system LED panel on the front or rear of the BladeCenter unit is lit, one or more error LEDs on the BladeCenter unit components also might be lit. These LEDs help identify the cause of the problem. For more information about the blade server error LEDs, see “Blade server light path diagnostics LEDs” on page 166.

- **Dynamic System Analysis (DSA) Portable Edition diagnostic program**

DSA tests the major components of the BladeCenter unit, including the management modules, I/O modules, removable-media drives, and the blade servers, while the operating system is running. For documentation and download information for DSA, see <http://www.ibm.com/systems/management/>. For more information about diagnostic programs and error messages, see “IBM Dynamic System Analysis Preboot diagnostic program” on page 170

**Note:** If you are unable to find the system-error logs in the blade server firmware code, view the system-event log in the BladeCenter management module.

- **Dynamic System Analysis (DSA) Preboot diagnostic program**

The DSA Preboot diagnostic programs are stored in read-only memory and collect and analyze system information to aid in diagnosing server problems. The diagnostic programs collect the following information about the server:

- Drive health information
- Event logs for ServeRAID controllers and service processors
- Hardware inventory, including PCI and USB information
- Light path diagnostics status
- LSI RAID and controller configuration
- Network interfaces and settings
- ServeRAID configuration
- Service processor status and configuration
- System configuration
- Vital product data, firmware, and Unified Extensible Firmware Interface (UEFI) configuration

The diagnostic programs create a merged log that includes events from all collected logs. The information is collected into a file that you can send to IBM service and support. Additionally, you can view the information locally through a generated text report file. You can also copy the log to removable media and view the log from a web browser.

---

## POST

Use this information for more about POST self-test errors for the blade server.

When you turn on the blade server, it performs a series of tests to check the operation of the blade server components and some optional devices in the blade server. This series of tests is called the power-on self-test, or POST.

If a power-on password is set, you must type the password and press Enter, when you are prompted, for POST to run.

If POST is completed without detecting any problems, the server startup will continue.

If POST detects a problem, an error message is displayed. See “UEFI/POST error codes” on page 88 for more information.

When new hardware is installed or the firmware for an expansion card has been updated, the blade server could fail during POST. If this occurs after three attempts to boot the blade server, the blade server will use the default configuration values; then, start the Setup utility (see “Using the Setup utility” on page 11). To allow the blade server to boot normally, complete the following steps:

1. If any configuration changes were made before the blade server became unable to boot, change the settings back to their original values.
2. If new hardware was added before the blade server became unable to boot, remove the new hardware and restart the server.
3. If the previous steps do not correct the problem and the blade server starts the Setup utility (see “Using the Setup utility” on page 11), select **Load Default Settings** and save the settings to restore the blade server to the default values.

## Event logs

Error codes and messages are displayed in the following types of event logs:

- **POST event log:** This log contains the three most recent error codes and messages that were generated during POST. You can view the POST event log through the Setup utility.
- **System-event log:** This log contains POST and system management interrupt (SMI) events and all events that are generated by the BMC that is embedded in the IMM. You can view the system-event log through the Setup utility and through the Dynamic System Analysis (DSA) program (as the IPMI event log). The system-event log is limited in size. When it is full, new entries will not overwrite existing entries; therefore, you must periodically save and then clear the system-event log through the Setup utility. When you are troubleshooting, you might have to save and then clear the system-event log to make the most recent events available for analysis.

Messages are listed on the left side of the screen, and details about the selected message are displayed on the right side of the screen. To move from one entry to the next, use the Up Arrow (↑) and Down Arrow (↓) keys.

Some IMM sensors cause assertion events to be logged when their setpoints are reached. When a setpoint condition no longer exists, a corresponding deassertion event is logged. However, not all events are assertion-type events.

- **Advanced management module event log:** This log contains a filtered subset of IMM, POST, and system management interrupt (SMI) events. You can view the advanced management module event log through the advanced management module web interface.
- **DSA log:** This log is generated by the Dynamic System Analysis (DSA) program, and it is a chronologically ordered merge of the system-event log (as the IPMI event log), the IMM event log (as the ASM event log), and the operating-system event logs. You can view the DSA log through the DSA program.

## Viewing event logs through the Setup utility

Use this information to view event logs through the Setup utility.

For complete information about using the Setup utility, see “Using the Setup utility” on page 11.

To view the POST event log or system-event log, complete the following steps:

1. Turn on the blade server.
2. When the prompt <F1> Setup is displayed, press F1. If you have set both a power-on password and an administrator password, you must type the administrator password to view the event logs.
3. Select **System Event Logs** and use one of the following procedures:
  - To view the POST event log, select **POST Event Viewer**.
  - To view the system-event log, select **System Event Log**.

## Viewing event logs without restarting the blade server

If the blade server is not hung, methods are available for you to view one or more event logs without having to restart the blade server.

You can view the advanced management module event log through the **Event Log** link in the advanced management module web interface. For more information, see the IBM BladeCenter Advanced Management Module: User's Guide at <http://www.ibm.com/supportportal/>.

If you have installed Dynamic System Analysis (DSA) Portable Edition, you can use it to view the system-event log (as the IPMI event log), the advanced management module event log (as the ASM event log), the operating-system event logs, or the merged DSA log. You can also use DSA Preboot to view these logs, although you must restart the blade server to use DSA Preboot. To install Portable DSA, Installable DSA, or DSA Preboot or to download a DSA Preboot CD image, go to <http://www.ibm.com/systems/support/supportsite.wss/docdisplay?Indocid=SERV-DSA&brandind=5000008>. or go to <http://www.ibm.com/supportportal/>.



If IPMItool is installed in the blade server, you can use it to view the system-event log. Most recent versions of the Linux operating system come with a current version of IPMItool. For information about IPMItool, see <http://publib.boulder.ibm.com/infocenter/lnxinfo/v3r0m0/index.jsp?topic=/liaai/ipmi/liaaiipmiother.htm> or complete the following steps.

**Note:** Changes are made periodically to the IBM website. The actual procedure might vary slightly from what is described in this document.

1. Go to <http://www.ibm.com/developerworks/linux/blueprints/>.
2. Click **Using Intelligent Platform Management Interface (IPMI) on IBM Linux platforms**.

The following table describes the methods that you can use to view the event logs, depending on the condition of the blade server. The first two conditions generally do not require that you restart the blade server.

Table 8. Methods for viewing event logs

Condition	Action
The blade server is not hung and is connected to a network.	Use any of the following methods: <ul style="list-style-type: none"> <li>• In a web browser, type the IP address of the advanced management module and go to the Event Log page.</li> <li>• Run Portable or Installable DSA to view the event logs or create an output file that you can send to IBM service and support.</li> <li>• Use IPMItool to view the system-event log.</li> </ul>
The blade server is not hung and is not connected to a network.	Use IPMItool locally to view the system-event log.
The blade server is hung.	<ul style="list-style-type: none"> <li>• If DSA Preboot is installed, restart the blade server and press F2 to start DSA Preboot and view the event logs.</li> <li>• If DSA Preboot is not installed, insert the DSA Preboot CD and restart the blade server to start DSA Preboot and view the event logs.</li> <li>• Alternatively, you can restart the blade server and press F1 to start the Setup utility and view the POST event log or system-event log. For more information, see “Viewing event logs through the Setup utility” on page 86.</li> </ul>

## UEFI/POST error codes

UEFI/POST diagnostic error codes can be generated when the server starts up or while the server is running. UEFI/POST codes are logged in the IMM event log in the server.

For each event code, the following fields are displayed:

### Event identifier

An identifier that uniquely identifies an event.

### Event description

The logged message string that appears for an event.

### Explanation

Additional information to explain why the event occurred.

## Severity

An indication of the level of concern for the condition. The following severities can be displayed:

Table 9. Event severity levels

Severity	Description
Informational	An informational message is something that was recorded for audit purposes, usually a user action or a change of states that is normal behavior.
Warning	A warning is not as severe as an error, but if possible, the condition should be corrected before it becomes an error. It might also be a condition that requires additional monitoring or maintenance.
Error	An error typically indicates a failure or critical condition that impairs service or an expected function.

## User response

Indicate the actions that you should take to resolve the event.

Perform the steps listed in this section in the order shown until the problem is solved. After you perform all of the actions that are described in this field, if you cannot solve the problem, contact IBM support.

The following is the list of the UEFI/POST error codes and suggested actions to correct the detected problems.

## UEFI/POST error codes

Use this information to diagnose and resolve UEFI/POST error for the blade server.

<ul style="list-style-type: none"> <li>Follow the suggested actions in the order in which they are listed in the Action column until the problem is solved.</li> <li>See Chapter 3 “Parts listing” on page 33 to determine which components are consumable, structural, or CRU parts.</li> <li>If an action step is preceded by “(Trained technician only),” that step must be performed only by a trained technician.</li> </ul>			
Diagnostic code	Message	Description	Action
I.11002	[I.11002] A processor mismatch has been detected between one or more processors in the system.	One or More Mismatched Processors Detected.	<ol style="list-style-type: none"> <li>Make sure the microprocessor is supported by the blade server. See <a href="http://www.ibm.com/systems/info/x86servers/serverproven/compat/us/">http://www.ibm.com/systems/info/x86servers/serverproven/compat/us/</a>.</li> <li>Check the IBM support website for an applicable retain tip or firmware update that applies to this error.</li> <li>Run the Setup utility and select <b>System Information</b> ® <b>System Summary</b> ® <b>Processor Details</b> to view the microprocessor information to compare the installed microprocessor specifications.</li> <li>(Trained technician only) Remove and replace one of the microprocessors so that they both match (see “Removing a microprocessor</li> </ol>

- Follow the suggested actions in the order in which they are listed in the Action column until the problem is solved.
- See Chapter 3 “Parts listing” on page 33 to determine which components are consumable, structural, or CRU parts.
- If an action step is preceded by “(Trained technician only),” that step must be performed only by a trained technician.

Diagnostic code	Message	Description	Action
			and heat sink” on page 70 and “Installing a microprocessor and heat sink” on page 73).
W.11004	[W.11004] A processor within the system has failed the BIST.	Processor Self Test Failure Detected.	<ol style="list-style-type: none"> <li>1. Check the IBM support website for an applicable retain tip or firmware update that applies to this error.</li> <li>2. (Trained technician only) If there are more than one microprocessor installed, swap the microprocessors. If the problem follows the affected microprocessor or there is only one microprocessor installed, replace the affected microprocessor (see “Removing a microprocessor and heat sink” on page 70 and “Installing a microprocessor and heat sink” on page 73).</li> <li>3. (Trained technician only) Replace the system board (see “Removing the system-board assembly” on page 78 and “Installing the system-board assembly” on page 79).</li> </ol>
S.1100B	[S.1100B] CATERR(IERR) has asserted on processor %.	Processor CATERR(IERR) has asserted.	<ol style="list-style-type: none"> <li>1. Check the IBM support website for an applicable retain tip or firmware update that applies to this error.</li> <li>2. (Trained technician only) Replace the microprocessor (see “Removing a microprocessor and heat sink” on page 70 and “Installing a microprocessor and heat sink” on page 73).</li> </ol>
S.1100C	[S.1100C] An uncorrectable error has been detected on processor %.	Uncorrectable processor error detected.	<ol style="list-style-type: none"> <li>1. Check the IBM support website for an applicable retain tip or firmware update that applies to this error.</li> <li>2. Restart the server.</li> <li>3. Contact your IBM service representative for support.</li> </ol> <p>(% = microprocessor number)</p>
I.18005	[I.18005] A discrepancy has been detected in the number of cores reported by one or more processor packages within the system.	Processors have mismatched number of cores.	<ol style="list-style-type: none"> <li>1. Make sure the microprocessor is supported by the blade server. See <a href="http://www.ibm.com/systems/info/x86servers/serverproven/compat/us/">http://www.ibm.com/systems/info/x86servers/serverproven/compat/us/</a>.</li> <li>2. Check the IBM support website for an applicable retain tip or firmware update that applies to this error.</li> <li>3. Run the Setup utility and select <b>System Information</b> ® <b>System Summary</b> ® <b>Processor Details</b> to view the microprocessor information to compare the installed microprocessor specifications.</li> </ol>

- Follow the suggested actions in the order in which they are listed in the Action column until the problem is solved.
- See Chapter 3 “Parts listing” on page 33 to determine which components are consumable, structural, or CRU parts.
- If an action step is preceded by “(Trained technician only),” that step must be performed only by a trained technician.

Diagnostic code	Message	Description	Action
			4. (Trained technician only) Remove and replace one of the microprocessors so that they both match (see “Removing a microprocessor and heat sink” on page 70 and “Installing a microprocessor and heat sink” on page 73).
I.18006	[I.18006] A mismatch between the maximum allowed QPI link speed has been detected for one or more processor packages.	Processors have mismatched QPI Speed.	<ol style="list-style-type: none"> <li>1. Make sure the microprocessor is supported by the blade server. See <a href="http://www.ibm.com/systems/info/x86servers/serverproven/compat/us/">http://www.ibm.com/systems/info/x86servers/serverproven/compat/us/</a>.</li> <li>2. Check the IBM support website for an applicable retain tip or firmware update that applies to this error.</li> <li>3. Run the Setup utility and select <b>System Information</b> ® <b>System Summary</b> ® <b>Processor Details</b> to view the microprocessor information to compare the installed microprocessor specifications.</li> <li>4. (Trained technician only) Remove and replace one of the microprocessors so that they both match (see “Removing a microprocessor and heat sink” on page 70 and “Installing a microprocessor and heat sink” on page 73).</li> </ol>
I.18007	[I.18007] A power segment mismatch has been detected for one or more processor packages.	Processors have mismatched Power Segments.	<ol style="list-style-type: none"> <li>1. Make sure the microprocessor is supported by the blade server. See <a href="http://www.ibm.com/systems/info/x86servers/serverproven/compat/us/">http://www.ibm.com/systems/info/x86servers/serverproven/compat/us/</a>.</li> <li>2. Check the IBM support website for an applicable retain tip or firmware update that applies to this error.</li> <li>3. Run the Setup utility and select <b>System Information</b> ® <b>System Summary</b> ® <b>Processor Details</b> to view the microprocessor information to compare the installed microprocessor specifications.</li> <li>4. (Trained technician only) Remove and replace one of the microprocessors so that they both match (see “Removing a microprocessor and heat sink” on page 70 and “Installing a microprocessor and heat sink” on page 73).</li> </ol>

- Follow the suggested actions in the order in which they are listed in the Action column until the problem is solved.
- See Chapter 3 “Parts listing” on page 33 to determine which components are consumable, structural, or CRU parts.
- If an action step is preceded by “(Trained technician only),” that step must be performed only by a trained technician.

Diagnostic code	Message	Description	Action
I.18008	[I.18008] Currently, there is no additional information for this event.	Processors have mismatched Internal DDR3 Frequency.	<ol style="list-style-type: none"> <li>1. Make sure the microprocessor is supported by the blade server. See <a href="http://www.ibm.com/systems/info/x86servers/serverproven/compat/us/">http://www.ibm.com/systems/info/x86servers/serverproven/compat/us/</a>.</li> <li>2. Check the IBM support website for an applicable retain tip or firmware update that applies to this error.</li> <li>3. Run the Setup utility and select <b>System Information</b> ® <b>System Summary</b> ® <b>Processor Details</b> to view the microprocessor information to compare the installed microprocessor specifications.</li> <li>4. (Trained technician only) Remove and replace one of the microprocessors so that they both match (see “Removing a microprocessor and heat sink” on page 70 and “Installing a microprocessor and heat sink” on page 73).</li> </ol>
I.18009	[I.18009] A core speed mismatch has been detected for one or more processor packages.	Processors have mismatched Core Speed.	<ol style="list-style-type: none"> <li>1. Make sure the microprocessor is supported by the blade server. See <a href="http://www.ibm.com/systems/info/x86servers/serverproven/compat/us/">http://www.ibm.com/systems/info/x86servers/serverproven/compat/us/</a>.</li> <li>2. Check the IBM support website for an applicable retain tip or firmware update that applies to this error.</li> <li>3. Run the Setup utility and select <b>System Information</b> ® <b>System Summary</b> ® <b>Processor Details</b> to view the microprocessor information to compare the installed microprocessor specifications.</li> <li>4. (Trained technician only) Remove and replace one of the microprocessors so that they both match (see “Removing a microprocessor and heat sink” on page 70 and “Installing a microprocessor and heat sink” on page 73).</li> </ol>

- Follow the suggested actions in the order in which they are listed in the Action column until the problem is solved.
- See Chapter 3 “Parts listing” on page 33 to determine which components are consumable, structural, or CRU parts.
- If an action step is preceded by “(Trained technician only),” that step must be performed only by a trained technician.

Diagnostic code	Message	Description	Action
I.1800A	[I.1800A] A mismatch has been detected between the speed at which a QPI link has trained between two or more processor packages.	Processors have mismatched Bus Speed.	<ol style="list-style-type: none"> <li>1. Make sure the microprocessor is supported by the blade server. See <a href="http://www.ibm.com/systems/info/x86servers/serverproven/compat/us/">http://www.ibm.com/systems/info/x86servers/serverproven/compat/us/</a>.</li> <li>2. Check the IBM support website for an applicable retain tip or firmware update that applies to this error.</li> <li>3. Run the Setup utility and select <b>System Information</b> ® <b>System Summary</b> ® <b>Processor Details</b> to view the microprocessor information to compare the installed microprocessor specifications.</li> <li>4. (Trained technician only) Remove and replace one of the microprocessors so that they both match (see “Removing a microprocessor and heat sink” on page 70 and “Installing a microprocessor and heat sink” on page 73).</li> </ol>
I.1800B	[I.1800B] A cache size mismatch has been detected for one or more processor packages.	Processors have one or more cache levels with mismatched size.	<ol style="list-style-type: none"> <li>1. Make sure the microprocessor is supported by the blade server. See <a href="http://www.ibm.com/systems/info/x86servers/serverproven/compat/us/">http://www.ibm.com/systems/info/x86servers/serverproven/compat/us/</a>.</li> <li>2. Check the IBM support website for an applicable retain tip or firmware update that applies to this error.</li> <li>3. Run the Setup utility and select <b>System Information</b> ® <b>System Summary</b> ® <b>Processor Details</b> to view the microprocessor information to compare the installed microprocessor specifications.</li> <li>4. (Trained technician only) Remove and replace one of the microprocessors so that they both match (see “Removing a microprocessor and heat sink” on page 70 and “Installing a microprocessor and heat sink” on page 73).</li> </ol>

- Follow the suggested actions in the order in which they are listed in the Action column until the problem is solved.
- See Chapter 3 “Parts listing” on page 33 to determine which components are consumable, structural, or CRU parts.
- If an action step is preceded by “(Trained technician only),” that step must be performed only by a trained technician.

Diagnostic code	Message	Description	Action
I.1800C	[I.1800C] A cache type mismatch has been detected for one or more processor packages.	Processors have one or more cache levels with mismatched type.	<ol style="list-style-type: none"> <li>1. Make sure the microprocessor is supported by the blade server. See <a href="http://www.ibm.com/systems/info/x86servers/serverproven/compat/us/">http://www.ibm.com/systems/info/x86servers/serverproven/compat/us/</a>.</li> <li>2. Check the IBM support website for an applicable retain tip or firmware update that applies to this error.</li> <li>3. Run the Setup utility and select <b>System Information</b> ® <b>System Summary</b> ® <b>Processor Details</b> to view the microprocessor information to compare the installed microprocessor specifications.</li> <li>4. (Trained technician only) Remove and replace one of the microprocessors so that they both match (see “Removing a microprocessor and heat sink” on page 70 and “Installing a microprocessor and heat sink” on page 73).</li> </ol>
I.1800D	[I.1800D] A cache associativity mismatch has been detected for one or more processor packages.	Processors have one or more cache levels with mismatched associativity.	<ol style="list-style-type: none"> <li>1. Make sure the microprocessor is supported by the blade server. See <a href="http://www.ibm.com/systems/info/x86servers/serverproven/compat/us/">http://www.ibm.com/systems/info/x86servers/serverproven/compat/us/</a>.</li> <li>2. Check the IBM support website for an applicable retain tip or firmware update that applies to this error.</li> <li>3. Run the Setup utility and select <b>System Information</b> ® <b>System Summary</b> ® <b>Processor Details</b> to view the microprocessor information to compare the installed microprocessor specifications.</li> <li>4. (Trained technician only) Remove and replace one of the microprocessors so that they both match (see “Removing a microprocessor and heat sink” on page 70 and “Installing a microprocessor and heat sink” on page 73).</li> </ol>

- Follow the suggested actions in the order in which they are listed in the Action column until the problem is solved.
- See Chapter 3 “Parts listing” on page 33 to determine which components are consumable, structural, or CRU parts.
- If an action step is preceded by “(Trained technician only),” that step must be performed only by a trained technician.

Diagnostic code	Message	Description	Action
I.1800E	[I.1800E] A processor model mismatch has been detected for one or more processor packages.	Processors have mismatched Model Number.	<ol style="list-style-type: none"> <li>1. Make sure the microprocessor is supported by the blade server. See <a href="http://www.ibm.com/systems/info/x86servers/serverproven/compat/us/">http://www.ibm.com/systems/info/x86servers/serverproven/compat/us/</a>.</li> <li>2. Check the IBM support website for an applicable retain tip or firmware update that applies to this error.</li> <li>3. Run the Setup utility and select <b>System Information</b> ® <b>System Summary</b> ® <b>Processor Details</b> to view the microprocessor information to compare the installed microprocessor specifications.</li> <li>4. (Trained technician only) Remove and replace one of the microprocessors so that they both match (see “Removing a microprocessor and heat sink” on page 70 and “Installing a microprocessor and heat sink” on page 73).</li> </ol>
I.1800F	[I.1800F] A processor family mismatch has been detected for one or more processor packages.	Processors have mismatched Family.	<ol style="list-style-type: none"> <li>1. Make sure the microprocessor is supported by the blade server. See <a href="http://www.ibm.com/systems/info/x86servers/serverproven/compat/us/">http://www.ibm.com/systems/info/x86servers/serverproven/compat/us/</a>.</li> <li>2. Check the IBM support website for an applicable retain tip or firmware update that applies to this error.</li> <li>3. Run the Setup utility and select <b>System Information</b> ® <b>System Summary</b> ® <b>Processor Details</b> to view the microprocessor information to compare the installed microprocessor specifications.</li> <li>4. (Trained technician only) Remove and replace one of the microprocessors so that they both match (see “Removing a microprocessor and heat sink” on page 70 and “Installing a microprocessor and heat sink” on page 73).</li> </ol>



- Follow the suggested actions in the order in which they are listed in the Action column until the problem is solved.
- See Chapter 3 “Parts listing” on page 33 to determine which components are consumable, structural, or CRU parts.
- If an action step is preceded by “(Trained technician only),” that step must be performed only by a trained technician.

Diagnostic code	Message	Description	Action
I.18010	[I.18010] A processor stepping mismatch has been detected for one or more processor packages.	Processors of the same model have mismatched Stepping ID.	<ol style="list-style-type: none"> <li>1. Make sure the microprocessor is supported by the blade server. See <a href="http://www.ibm.com/systems/info/x86servers/serverproven/compat/us/">http://www.ibm.com/systems/info/x86servers/serverproven/compat/us/</a>.</li> <li>2. Check the IBM support website for an applicable retain tip or firmware update that applies to this error.</li> <li>3. Run the Setup utility and select <b>System Information</b> ® <b>System Summary</b> ® <b>Processor Details</b> to view the microprocessor information to compare the installed microprocessor specifications.</li> <li>4. (Trained technician only) Remove and replace one of the microprocessors so that they both match (see “Removing a microprocessor and heat sink” on page 70 and “Installing a microprocessor and heat sink” on page 73).</li> </ol>
W.50001	[W.50001] A DIMM has been disabled due to an error detected during POST.	DIMM Disabled.	<ol style="list-style-type: none"> <li>1. If the memory module was disabled due to a memory fault, follow the procedure for that event and restart the server.</li> <li>2. Check the IBM support website for an applicable retain tip or firmware update that applies to this memory event. If no memory fault is recorded in the logs and no DIMM connector error LED is lit, re-enable the memory modules using the Setup utility or the Advanced Settings Utility (ASU).</li> <li>3. If the problem remains, replace the affected DIMM (see “Removing a memory module” on page 54 and “Installing a memory module” on page 55).</li> <li>4. (Trained technician only) Replace the system-board assembly (see “Removing the system-board assembly” on page 78 and “Installing the system-board assembly” on page 79).</li> </ol>

- Follow the suggested actions in the order in which they are listed in the Action column until the problem is solved.
- See Chapter 3 “Parts listing” on page 33 to determine which components are consumable, structural, or CRU parts.
- If an action step is preceded by “(Trained technician only),” that step must be performed only by a trained technician.

Diagnostic code	Message	Description	Action
S.51003	<p>[S.51003] An uncorrectable memory error was detected in DIMM slot % on rank %.</p> <p>[S.51003] An uncorrectable memory error was detected on processor % channel %. The failing DIMM within the channel could not be determined.</p> <p>[S.51003] An uncorrectable memory error has been detected during POST.</p>	Fatal Memory Error Occurred.	<ol style="list-style-type: none"> <li>1. Refer to TIP H21455 for minimum code level.</li> <li>2. Check the IBM support website for an applicable retain tip or firmware update that applies to this memory error.</li> <li>3. If the problem remains, replace the affected DIMMs (see “Removing a memory module” on page 54 and “Installing a memory module” on page 55).</li> <li>4. (Trained technician only) If the problem occurs on the same DIMM connector, check the DIMM connector. If the connector contains any foreign material or is damaged, replace the system-board assembly (see “Removing the system-board assembly” on page 78 and “Installing the system-board assembly” on page 79).</li> <li>5. (Trained technician only) Remove the affected microprocessor and check the microprocessor socket pins for any damaged pins. If a damage is found, replace the system-board assembly.</li> <li>6. (Trained technician only) Replace the affected microprocessor (see “Removing a microprocessor and heat sink” on page 70 and “Installing a microprocessor and heat sink” on page 73).</li> </ol>
S.51006	[S.51006] A memory mismatch has been detected. Please verify that the memory configuration is valid.	One or More Mismatched DIMMs Detected.	Make sure that the DIMMs have been installed in the correct sequence (see “Installing a memory module” on page 55).
S.51009	[S.51009] No system memory has been detected.	No Memory Detected.	<ol style="list-style-type: none"> <li>1. Make sure that there is at least one DIMM installed in the server.</li> <li>2. If there are no memory fault recorded in the logs and no DIMM connector error LEDs are lit, make sure that all DIMM connectors are enabled by using the Setup utility or the Advance Settings Utility (ASU).</li> <li>3. Reinstall all DIMMs in the correct population sequence (see “Installing a memory module” on page 55 for more information).</li> </ol>

- Follow the suggested actions in the order in which they are listed in the Action column until the problem is solved.
- See Chapter 3 “Parts listing” on page 33 to determine which components are consumable, structural, or CRU parts.
- If an action step is preceded by “(Trained technician only),” that step must be performed only by a trained technician.

Diagnostic code	Message	Description	Action
W.58001	[W.58001] The PFA Threshold limit (correctable error logging limit) has been exceeded on DIMM number % at address %. MC5 Status contains % and MC5 Misc contains %.	DIMM PFA Threshold Exceeded.	<ol style="list-style-type: none"> <li>1. Refer to TIP H21455 for minimum code level.</li> <li>2. Check the IBM support website for an applicable retain tip or firmware update that applies to this memory error.</li> <li>3. Swap the affected DIMMs (as indicated by the error LEDs on the system board or the event logs) to a different memory channel or microprocessor (see “Installing a memory module” on page 55 for memory population sequence).</li> <li>4. If the error still occurs on the same DIMM, replace the affected DIMM.</li> <li>5. (Trained technician only) If the problem occurs on the same DIMM connector, check the DIMM connector. If the connector is damaged, replace the system-board assembly (see “Removing the system-board assembly” on page 78 and “Installing the system-board assembly” on page 79).</li> <li>6. (Trained technician only) Remove the affected microprocessor and check the microprocessor socket pins for any damaged pins. If a damage is found, replace the system-board assembly (see “Removing the system-board assembly” on page 78 and “Installing the system-board assembly” on page 79).</li> <li>7. (Trained technician only) Replace the affected microprocessor (See “Removing a microprocessor and heat sink” on page 70 and “Installing a microprocessor and heat sink” on page 73).</li> <li>8. (Trained technician only) Replace the system board (see “Removing the system-board assembly” on page 78 and “Installing the system-board assembly” on page 79).</li> </ol>
W.58007	[W.58007] Invalid memory configuration (Unsupported DIMM Population) detected. Please verify the memory configuration is valid.	Unsupported DIMM Population.	<ol style="list-style-type: none"> <li>1. If the memory module was disabled due to a memory fault, follow the procedure for that event and restart the server.</li> <li>2. Make sure that the DIMMs are installed in the proper sequence (see “Installing a memory module” on page 55).</li> </ol>

- Follow the suggested actions in the order in which they are listed in the Action column until the problem is solved.
- See Chapter 3 “Parts listing” on page 33 to determine which components are consumable, structural, or CRU parts.
- If an action step is preceded by “(Trained technician only),” that step must be performed only by a trained technician.

Diagnostic code	Message	Description	Action
S.58008	[S.58008] A DIMM has failed the POST memory test.	DIMM Failed Memory Test.	<ol style="list-style-type: none"> <li>1. Refer to TIP H21455 for minimum code level.</li> <li>2. Check the IBM support website for an applicable retain tip or firmware update that applies to this memory error.</li> <li>3. Install the affected memory modules (as indicated by the error LEDs on the system board or the event logs) in a different memory channel or microprocessor (see “Installing a memory module” on page 55 for memory population sequence).</li> <li>4. If the error still occurs on the same memory module, replace the affected memory module.</li> <li>5. (Trained technician only) If the problem occurs on the same DIMM connector, check the DIMM connector. If the connector is damaged, replace the system-board assembly (see “Removing the system-board assembly” on page 78 and “Installing the system-board assembly” on page 79).</li> <li>6. (Trained technician only) Remove the affected microprocessor and check the microprocessor socket pins for any damaged pins. If a damage is found, replace the system-board assembly (see “Removing the system-board assembly” on page 78 and “Installing the system-board assembly” on page 79).</li> <li>7. (Trained technician only) Replace the affected microprocessor (See “Removing a microprocessor and heat sink” on page 70 and “Installing a microprocessor and heat sink” on page 73).</li> </ol>
W.580A1	[W.580A1] Invalid memory configuration for Mirror Mode. Please correct the memory configuration.	Unsupported DIMM Population for Mirror Mode.	<ol style="list-style-type: none"> <li>1. If a DIMM connector error LED is lit on the system board, check the event logs and follow the procedure for that event and restart the server.</li> <li>2. Make sure that the DIMMs have been installed in the correct sequence for mirroring mode (see “Installing a memory module” on page 55).</li> </ol>

- Follow the suggested actions in the order in which they are listed in the Action column until the problem is solved.
- See Chapter 3 “Parts listing” on page 33 to determine which components are consumable, structural, or CRU parts.
- If an action step is preceded by “(Trained technician only),” that step must be performed only by a trained technician.

Diagnostic code	Message	Description	Action
W.580A2	[W.580A2] Invalid memory configuration for Sparing Mode. Please correct the memory configuration.	Unsupported DIMM Population for Spare Mode.	<ol style="list-style-type: none"> <li>1. If a DIMM connector error LED is lit on the system board, check the event logs and follow the procedure for that event and restart the server.</li> <li>2. Make sure that the DIMMs have been installed in the correct sequence for sparing mode (see “Installing a memory module” on page 55).</li> </ol>
I.580A4	[I.580A4] Memory population change detected.	DIMM Population Change Detected.	Information only. Memory has been added, moved, or changed.
I.580A5	[I.580A5] Mirror fail-over complete. DIMM number % has failed over to the mirrored copy.	DIMM Mirror Fail-over Detected.	Information only. Memory redundancy has been lost. Check the event log for uncorrected DIMM failure events (see “Event logs” on page 85).
I.580A6	[I.580A6] Memory spare copy has completed successfully.	Spare Copy Complete.	Information only. Memory redundancy or spare rank has been lost. Check the event log for uncorrected DIMM failure events (see “Event logs” on page 85).
I.58015	[I.58015] Memory spare copy initiated.	Spare Copy Started.	No action; information only.
W.68002	[W.68002] A CMOS battery error has been detected.	CMOS Battery Fault.	<ol style="list-style-type: none"> <li>1. Reseat the battery.</li> <li>2. Clear the CMOS memory (see “System-board switch” on page 8).</li> <li>3. Replace the following components one at a time in the order shown, restarting the server each time: <ul style="list-style-type: none"> <li>• Battery (see “Removing the battery” on page 51 and “Installing the battery” on page 51).</li> <li>• (Trained technician only) System board. See “Removing the system-board assembly” on page 78 and “Installing the system-board assembly” on page 79.</li> </ul> </li> </ol>

- Follow the suggested actions in the order in which they are listed in the Action column until the problem is solved.
- See Chapter 3 “Parts listing” on page 33 to determine which components are consumable, structural, or CRU parts.
- If an action step is preceded by “(Trained technician only),” that step must be performed only by a trained technician.

Diagnostic code	Message	Description	Action
S.68005	[S.68005] An error has been detected by the I/O core logic on Bus %. The Global Fatal Error Status register contains %. The Global Non-Fatal Error Status register contains %. Please check error logs for the presence of additional downstream device error data.	Critical IOH-PCI Error.	<ol style="list-style-type: none"> <li>1. Check the IBM support website for an applicable retain tip or firmware update that applies to this error.</li> <li>2. Reseat the expansion cards (see “Removing an I/O expansion card” on page 60 and “Installing an I/O expansion card” on page 62).</li> <li>3. Replace the following components one at a time in the order shown, restarting the server each time: <ul style="list-style-type: none"> <li>• Expansion cards (see “Removing an I/O expansion card” on page 60 and “Installing an I/O expansion card” on page 62).</li> <li>• (Trained technician only) Replace the system board (see “Removing the system-board assembly” on page 78 and “Installing the system-board assembly” on page 79).</li> </ul> </li> </ol>
S.680B8	[S.680B8] Internal QPI Link Failure Detected.	Internal QPI Link Failure Detected.	<ol style="list-style-type: none"> <li>1. Check the IBM support website for an applicable retain tip or firmware update that applies to this error.</li> <li>2. Inspect the microprocessor socket for the foreign material or damage. If any foreign material is found, remove the foreign material.</li> <li>3. Inspect the microprocessor socket for foreign material, if the microprocessor socket contains any foreign material, remove the foreign material. If it is found damaged, (trained technician only) replace the system board (see “Removing the system-board assembly” on page 78 and “Installing the system-board assembly” on page 79).</li> </ol>
S.680B9	[S.680B9] External QPI Link Failure Detected.	External QPI Link Failure Detected.	<ol style="list-style-type: none"> <li>1. Check the IBM support website for an applicable retain tip or firmware update that applies to this error.</li> <li>2. Inspect the microprocessor socket for the foreign material or damage. If any foreign material is found, remove the foreign material.</li> <li>3. Inspect the microprocessor socket for foreign material, if the microprocessor socket contains any foreign material, remove the foreign material. If it is found damaged, (trained technician only) replace the system board (see “Removing the system-board assembly” on page 78 and “Installing the system-board assembly” on page 79).</li> </ol>

- Follow the suggested actions in the order in which they are listed in the Action column until the problem is solved.
- See Chapter 3 “Parts listing” on page 33 to determine which components are consumable, structural, or CRU parts.
- If an action step is preceded by “(Trained technician only),” that step must be performed only by a trained technician.

Diagnostic code	Message	Description	Action
			assembly” on page 78 and “Installing the system-board assembly” on page 79).
S.2011001	[S.2011001] An Uncorrected PCIe Error has Occurred at Bus % Device % Function %. The Vendor ID for the device is % and the Device ID is %.	PCI SERR Detected.	<ol style="list-style-type: none"> <li>1. Reseat the expansion card (see “Removing an I/O expansion card” on page 60 and “Installing an I/O expansion card” on page 62).</li> <li>2. Check the IBM support website for an applicable retain tip or firmware update that applies to this error.</li> <li>3. If the problem still remains, remove the expansion card. If the system restart successfully without the expansion card, replace the expansion card (see “Removing an I/O expansion card” on page 60 and “Installing an I/O expansion card” on page 62).</li> <li>4. (Trained technician only) Replace the microprocessor (see “Removing a microprocessor and heat sink” on page 70 and “Installing a microprocessor and heat sink” on page 73).</li> </ol>
S.2018001	[S.2018001] An Uncorrected PCIe Error has Occurred at Bus % Device % Function %. The Vendor ID for the device is % and the Device ID is %.	PCIe Uncorrected Error Detected.	<ol style="list-style-type: none"> <li>1. Reseat the expansion card (see “Removing an I/O expansion card” on page 60 and “Installing an I/O expansion card” on page 62).</li> <li>2. Check the IBM support website for an applicable retain tip or firmware update that applies to this error.</li> <li>3. If the problem still remains, remove the expansion card. If the system restart successfully without the expansion card, replace the expansion card (see “Removing an I/O expansion card” on page 60 and “Installing an I/O expansion card” on page 62).</li> <li>4. (Trained technician only) Replace the microprocessor (see “Removing a microprocessor and heat sink” on page 70 and “Installing a microprocessor and heat sink” on page 73).</li> </ol>

- Follow the suggested actions in the order in which they are listed in the Action column until the problem is solved.
- See Chapter 3 “Parts listing” on page 33 to determine which components are consumable, structural, or CRU parts.
- If an action step is preceded by “(Trained technician only),” that step must be performed only by a trained technician.

Diagnostic code	Message	Description	Action
I.2018002	[I.2018002] The device found at Bus % Device % Function % could not be configured due to resource constraints. The Vendor ID for the device is % and the Device ID is %.	OUT_OF_RESOURCES (PCI Option ROM).	<ol style="list-style-type: none"> <li>1. Run the Setup utility (see “Using the Setup utility” on page 11). Select <b>Start Options</b> from the menu and modify the boot sequence so that you change the load order of the optional-device ROM code.</li> <li>2. Run the Setup utility (see “Using the Setup utility” on page 11) and disable unused resource to make more space available: <ul style="list-style-type: none"> <li>• Select <b>Start Options</b></li> <li>• Select <b>Planar Ethernet (PXE/DHCP)</b> to disable the on-board Ethernet controller ROM.</li> <li>• Select <b>Advanced Functions</b>, followed by <b>PCI Bus Control</b>, and then <b>PCI ROM Control Execution</b> to disable the ROM of the adapters in the PCI slots.</li> <li>• Select <b>Devices and I/O Ports</b> to disable any of the on-board devices.</li> </ul> </li> <li>3. If the problem remains, replace the following components one at a time in the order shown, restarting the server each time: <ul style="list-style-type: none"> <li>• Expansion cards (see “Removing an I/O expansion card” on page 60 and “Installing an I/O expansion card” on page 62).</li> <li>• (Trained technician only) Replace the system board (see “Removing the system-board assembly” on page 78 and “Installing the system-board assembly” on page 79).</li> </ul> </li> <li>4. See retain tip H197144 <a href="http://www-947.ibm.com/support/entry/portal/docdisplay?Indoc">http://www-947.ibm.com/support/entry/portal/docdisplay?Indoc</a> for more information.</li> </ol>
I.2018003	[I.2018003] A bad option ROM checksum was detected for the device found at Bus % Device % Function %. The Vendor ID for the device is % and the Device ID is %.	ROM CHECKSUM ERROR.	<ol style="list-style-type: none"> <li>1. Run the Setup utility (see “Using the Setup utility” on page 11). Select <b>Start Options</b> from the menu and modify the boot sequence so that you change the load order of the optional-device ROM code.</li> <li>2. Run the Setup utility (see “Using the Setup utility” on page 11) and disable unused resource to make more space available: <ul style="list-style-type: none"> <li>• Select <b>Start Options</b></li> <li>• Select <b>Planar Ethernet (PXE/DHCP)</b> to disable the on-board Ethernet controller ROM.</li> </ul> </li> </ol>



- Follow the suggested actions in the order in which they are listed in the Action column until the problem is solved.
- See Chapter 3 “Parts listing” on page 33 to determine which components are consumable, structural, or CRU parts.
- If an action step is preceded by “(Trained technician only),” that step must be performed only by a trained technician.

Diagnostic code	Message	Description	Action
			<ul style="list-style-type: none"> <li>• Select <b>Advanced Functions</b>, followed by <b>PCI Bus Control</b>, and then <b>PCI ROM Control Execution</b> to disable the ROM of the adapters in the PCI slots.</li> <li>• Select <b>Devices and I/O Ports</b> to disable any of the on-board devices.</li> </ul> <p>3. If the problem remains, replace the following components one at a time in the order shown, restarting the server each time:</p> <ul style="list-style-type: none"> <li>• Expansion cards (see “Removing an I/O expansion card” on page 60 and “Installing an I/O expansion card” on page 62).</li> <li>• (Trained technician only) Replace the system board (see “Removing the system-board assembly” on page 78 and “Installing the system-board assembly” on page 79).</li> </ul>
S.3020007	[S.3020007] A firmware fault has been detected in the UEFI image.	Internal UEFI Firmware Fault Detected, System halted.	<ol style="list-style-type: none"> <li>1. Check the IBM support website for an applicable retain tip or firmware update that applies to this error.</li> <li>2. Recover the server firmware (see “Recovering from a UEFI update failure” on page 192).</li> <li>3. (Trained technician only) Replace the system board (see “Removing the system-board assembly” on page 78 and “Installing the system-board assembly” on page 79).</li> </ol>
S.3028002	[S.3028002] Boot permission timeout detected.	Boot Permission Negotiation Timeout.	<ol style="list-style-type: none"> <li>1. Check the IMM event logs (see “IMM error messages” on page 109) for communication errors and follow the actions to resolve the error.</li> <li>2. Reseat the blade server (see “Removing the blade server from the BladeCenter unit” on page 41 and “Installing the blade server in a BladeCenter unit” on page 41).</li> <li>3. If the problem remains, contact your IBM service representative for support.</li> </ol>

- Follow the suggested actions in the order in which they are listed in the Action column until the problem is solved.
- See Chapter 3 “Parts listing” on page 33 to determine which components are consumable, structural, or CRU parts.
- If an action step is preceded by “(Trained technician only),” that step must be performed only by a trained technician.

Diagnostic code	Message	Description	Action
S.3030007	[S.3030007] A firmware fault has been detected in the UEFI image.	Internal UEFI Firmware Fault Detected, System halted.	<ol style="list-style-type: none"> <li>1. Check the IBM support website for an applicable retain tip or firmware update that applies to this error.</li> <li>2. Recover the server firmware (see “Recovering from a UEFI update failure” on page 192).</li> <li>3. (Trained technician only) Replace the system board (see “Removing the system-board assembly” on page 78 and “Installing the system-board assembly” on page 79).</li> </ol>
S.3040007	[S.3040007] A firmware fault has been detected in the UEFI image.	Internal UEFI Firmware Fault Detected, System halted.	<ol style="list-style-type: none"> <li>1. Check the IBM support website for an applicable retain tip or firmware update that applies to this error.</li> <li>2. Recover the server firmware (see “Recovering from a UEFI update failure” on page 192).</li> <li>3. (Trained technician only) Replace the system board (see “Removing the system-board assembly” on page 78 and “Installing the system-board assembly” on page 79).</li> </ol>
I.3048005	[I.3048005] UEFI has booted from the backup flash bank.	Booting Backup UEFI Image.	Information only. Set SW1-5 to the on position to allow the server to boot from the backup UEFI (see “System-board switch” on page 8).
W.3048006	[W.3048006] UEFI has booted from the backup flash bank due to an Automatic Boot Recovery (ABR) event.	Automated Boot Recovery, Booting Backup UEFI Image.	<ol style="list-style-type: none"> <li>1. Run the Setup utility (see “Using the Setup utility” on page 11), select Load Default Settings, and save the settings.</li> <li>2. Recover the server firmware (see “Recovering from a UEFI update failure” on page 192).</li> <li>3. (Trained technician only) Replace the system board (see “Removing the system-board assembly” on page 78 and “Installing the system-board assembly” on page 79).</li> </ol>
S.3050007	[S.3050007] A firmware fault has been detected in the UEFI image.	Internal UEFI Firmware Fault Detected, System halted.	<ol style="list-style-type: none"> <li>1. Check the IBM support website for an applicable retain tip or firmware update that applies to this error.</li> <li>2. Recover the server firmware (see “Recovering from a UEFI update failure” on page 192).</li> </ol>
W.305000A	[W.305000A] An invalid date and time have been detected.	RTC Date and Time Incorrect.	<ol style="list-style-type: none"> <li>1. Run the Setup utility (see “Using the Setup utility” on page 11). Select <b>Load Default Settings</b> and save the settings.</li> <li>2. Reseat the battery (see “Removing the battery” on page 51 and “Installing the battery” on page 51).</li> <li>3. Replace the battery (see “Removing the battery” on page 51 and “Installing the battery” on page 51).</li> </ol>

- Follow the suggested actions in the order in which they are listed in the Action column until the problem is solved.
- See Chapter 3 “Parts listing” on page 33 to determine which components are consumable, structural, or CRU parts.
- If an action step is preceded by “(Trained technician only),” that step must be performed only by a trained technician.

Diagnostic code	Message	Description	Action
S.3058004	[S.3058004] A Three Strike boot failure has occurred. The system has booted with default UEFI settings.	POST failure has occurred! System booted with default settings.	<ol style="list-style-type: none"> <li>1. Undo any recent system changes, such as new settings or newly installed devices.</li> <li>2. Make sure that the server is attached to a reliable power source.</li> <li>3. Remove all hardware that is not supported by the server (see <a href="http://www.ibm.com/systems/info/x86servers/serverproven/compat/us/">http://www.ibm.com/systems/info/x86servers/serverproven/compat/us/</a>).</li> <li>4. Update the firmware to the latest level (see “Updating firmware and device drivers” on page 23 for more information).</li> <li>5. Make sure that the operating system is not corrupt.</li> <li>6. Run the Setup utility, save the configuration, and then restart the server.</li> <li>7. (Trained technician only) If the problem remains, replace the system board (see “Removing the system-board assembly” on page 78 and “Installing the system-board assembly” on page 79).</li> </ol>
W.3058009	[W.3058009] Driver health protocol: missing configuration. Requires change settings From F1.	DRIVER HEALTH PROTOCOL: Missing Configuration. Requires Change Settings From F1.	<ol style="list-style-type: none"> <li>1. Select <b>System Settings</b> ® <b>Settings</b> ® <b>Driver Health Status List</b> and find a driver/controller reporting configuration required status.</li> <li>2. Search for the driver menu from <b>System Settings</b> and change the settings appropriately.</li> <li>3. Save the settings and restart the system.</li> </ol>
W.305800A	[W.305800A] Driver health protocol: Reports "failed" status controller.	DRIVER HEALTH PROTOCOL: Reports 'Failed' Status Controller.	<ol style="list-style-type: none"> <li>1. Restart the system.</li> <li>2. If the problem persists, switch to the backup UEFI image or reload the current UEFI image.</li> <li>3. (Trained technician only) Replace the system board (see “Removing the system-board assembly” on page 78 and “Installing the system-board assembly” on page 79).</li> </ol>
W.305800B	[W.305800B] Driver health protocol: Reports "reboot" required controller.	DRIVER HEALTH PROTOCOL: Reports 'Reboot' Required Controller.	<ol style="list-style-type: none"> <li>1. No action required. The system will reboot at the end of POST.</li> <li>2. If the problem persists, switch to the backup UEFI image or reload the current UEFI image.</li> <li>3. (Trained technician only) Replace the system board (see “Removing the system-board assembly” on page 78 and “Installing the system-board assembly” on page 79).</li> </ol>

- Follow the suggested actions in the order in which they are listed in the Action column until the problem is solved.
- See Chapter 3 “Parts listing” on page 33 to determine which components are consumable, structural, or CRU parts.
- If an action step is preceded by “(Trained technician only),” that step must be performed only by a trained technician.

Diagnostic code	Message	Description	Action
W.305800C	[W.305800C] Driver health protocol: Reports "system shutdown" required controller.	DRIVER HEALTH PROTOCOL: Reports 'System Shutdown' Required Controller.	<ol style="list-style-type: none"> <li>1. Restart the system.</li> <li>2. If the problem persists, switch to the backup UEFI image or reload the current UEFI image.</li> <li>3. (Trained technician only) Replace the system board (see “Removing the system-board assembly” on page 78 and “Installing the system-board assembly” on page 79).</li> </ol>
W.305800D	[W.305800D] Driver health protocol: Disconnect controller failed. Requires "reboot".	DRIVER HEALTH PROTOCOL: Disconnect Controller Failed. Requires 'Reboot'.	<ol style="list-style-type: none"> <li>1. Restart the system.</li> <li>2. If the problem persists, switch to the backup UEFI image or reload the current UEFI image.</li> <li>3. (Trained technician only) Replace the system board (see “Removing the system-board assembly” on page 78 and “Installing the system-board assembly” on page 79).</li> </ol>
W.305800E	[W.305800E] Driver health protocol: Reports invalid health status driver.	DRIVER HEALTH PROTOCOL: Reports Invalid Health Status Driver.	<ol style="list-style-type: none"> <li>1. Restart the system.</li> <li>2. If the problem persists, switch to the backup UEFI image or reload the current UEFI image.</li> <li>3. (Trained technician only) Replace the system board (see “Removing the system-board assembly” on page 78 and “Installing the system-board assembly” on page 79).</li> </ol>
S.3060007	[S.3060007] A firmware fault has been detected in the UEFI image.	Internal UEFI Firmware Fault Detected, System halted.	<ol style="list-style-type: none"> <li>1. Check the IBM support website for an applicable retain tip or firmware update that applies to this error.</li> <li>2. Recover the server firmware (see “Recovering from a UEFI update failure” on page 192).</li> </ol>
S.3070007	[S.3070007] A firmware fault has been detected in the UEFI image.	Internal UEFI Firmware Fault Detected, System halted.	<ol style="list-style-type: none"> <li>1. Check the IBM support website for an applicable retain tip or firmware update that applies to this error.</li> <li>2. Recover the server firmware (see “Recovering from a UEFI update failure” on page 192).</li> </ol>
S.3108007	[S.3108007 ] The default system settings have been restored.	System Configuration Restored to Defaults.	<ol style="list-style-type: none"> <li>1. Check the IBM support website for an applicable retain tip or firmware update that applies to this error.</li> <li>2. If the settings differ from defaults, run the Setup utility, select <b>Load Default Settings</b>, and save the settings.</li> </ol>

- Follow the suggested actions in the order in which they are listed in the Action column until the problem is solved.
- See Chapter 3 “Parts listing” on page 33 to determine which components are consumable, structural, or CRU parts.
- If an action step is preceded by “(Trained technician only),” that step must be performed only by a trained technician.

Diagnostic code	Message	Description	Action
W.3808000	[W.3808000] An IMM communication failure has occurred.	IMM Communication Failure.	<ol style="list-style-type: none"> <li>1. Reseat the blade server (see “Removing the blade server from the BladeCenter unit” on page 41 and “Installing the blade server in a BladeCenter unit” on page 41).</li> <li>2. Update the IMM2 firmware (see “Updating firmware and device drivers” on page 23).</li> <li>3. (Trained technician only) If the problem remains, replace the system board (see “Removing the system-board assembly” on page 78 and “Installing the system-board assembly” on page 79).</li> </ol>
W.3808002	[W.3808002] An error occurred while saving UEFI settings to the IMM.	Error Updating System Configuration to IMM.	<ol style="list-style-type: none"> <li>1. Run the Setup utility, save the configuration, and restart the server (see “Using the Setup utility” on page 11).</li> <li>2. Update the IMM2 firmware (see “Updating firmware and device drivers” on page 23).</li> <li>3. (Trained technician only) If the problem remains, replace the system board (see “Removing the system-board assembly” on page 78 and “Installing the system-board assembly” on page 79).</li> </ol>
W.3808003	[W.3808003] Unable to retrieve the system configuration from the IMM.	Error Retrieving System Configuration from IMM.	<ol style="list-style-type: none"> <li>1. Run the Setup utility, save the configuration, and restart the server (see “Using the Setup utility” on page 11).</li> <li>2. Update the IMM2 firmware (see “Updating firmware and device drivers” on page 23).</li> <li>3. (Trained technician only) If the problem remains, replace the system board (see “Removing the system-board assembly” on page 78 and “Installing the system-board assembly” on page 79).</li> </ol>
I.3808004	[I.3808004] The IMM System Event Log (SEL) is full.	IPMI System Event Log is Full.	Run the Setup utility to clear IMM2 logs and restart the server (see “Using the Setup utility” on page 11).
I.3818001	[I.3818001] The firmware image capsule signature for the currently booted flash bank is invalid.	Current Bank CRTM Capsule Update Signature Invalid.	<ol style="list-style-type: none"> <li>1. Run the Setup utility (see “Using the Setup utility” on page 11), select <b>Load Default Settings</b>, and save the settings.</li> <li>2. Recover the server firmware (see “Recovering from a UEFI update failure” on page 192).</li> <li>3. (Trained technician only) Replace the system board (see “Removing the system-board assembly” on page 78 and “Installing the system-board assembly” on page 79).</li> </ol>

- Follow the suggested actions in the order in which they are listed in the Action column until the problem is solved.
- See Chapter 3 “Parts listing” on page 33 to determine which components are consumable, structural, or CRU parts.
- If an action step is preceded by “(Trained technician only),” that step must be performed only by a trained technician.

Diagnostic code	Message	Description	Action
I.3818002	[I.3818002] The firmware image capsule signature for the non-booted flash bank is invalid.	Opposite Bank CRTM Capsule Update Signature Invalid.	<ol style="list-style-type: none"> <li>1. Run the Setup utility (see “Using the Setup utility” on page 11), select <b>Load Default Settings</b>, and save the settings.</li> <li>2. Recover the server firmware (see “Recovering from a UEFI update failure” on page 192).</li> <li>3. (Trained technician only) Replace the system board (see “Removing the system-board assembly” on page 78 and “Installing the system-board assembly” on page 79).</li> </ol>
I.3818003	[I.3818003] The CRTM flash driver could not lock the secure flash region.	CRTM Could not lock secure flash region.	<ol style="list-style-type: none"> <li>1. Run the Setup utility (see “Using the Setup utility” on page 11), select <b>Load Default Settings</b>, and save the settings.</li> <li>2. Recover the server firmware (see “Recovering from a UEFI update failure” on page 192).</li> <li>3. (Trained technician only) Replace the system board (see “Removing the system-board assembly” on page 78 and “Installing the system-board assembly” on page 79).</li> </ol>
S.3818004	[S.3818004] The CRTM flash driver could not successfully flash the staging area. A failure occurred.	CRTM Update Failed.	<ol style="list-style-type: none"> <li>1. Run the Setup utility (see “Using the Setup utility” on page 11), select <b>Load Default Settings</b>, and save the settings.</li> <li>2. Recover the server firmware (see “Recovering from a UEFI update failure” on page 192).</li> <li>3. (Trained technician only) Replace the system board (see “Removing the system-board assembly” on page 78 and “Installing the system-board assembly” on page 79).</li> </ol>
W.3818005	[W.3818005] The CRTM flash driver could not successfully flash the staging area. The update was aborted.	CRTM Update Aborted.	<ol style="list-style-type: none"> <li>1. Run the Setup utility (see “Using the Setup utility” on page 11), select <b>Load Default Settings</b>, and save the settings.</li> <li>2. Recover the server firmware (see “Recovering from a UEFI update failure” on page 192).</li> <li>3. (Trained technician only) Replace the system board (see “Removing the system-board assembly” on page 78 and “Installing the system-board assembly” on page 79).</li> </ol>
S.3818007	[S.3818007] The firmware image capsules for both flash banks could not be verified.	CRTM image capsule could not be verified.	<ol style="list-style-type: none"> <li>1. Run the Setup utility (see “Using the Setup utility” on page 11), select <b>Load Default Settings</b>, and save the settings.</li> <li>2. Recover the server firmware (see “Recovering from a UEFI update failure” on page 192).</li> <li>3. (Trained technician only) Replace the system board (see “Removing the system-board assembly” on page 78 and “Installing the system-board assembly” on page 79).</li> </ol>

<ul style="list-style-type: none"> <li>• Follow the suggested actions in the order in which they are listed in the Action column until the problem is solved.</li> <li>• See Chapter 3 “Parts listing” on page 33 to determine which components are consumable, structural, or CRU parts.</li> <li>• If an action step is preceded by “(Trained technician only),” that step must be performed only by a trained technician.</li> </ul>			
Diagnostic code	Message	Description	Action
S.381800D	[W.381800D] TPM physical presence is in asserted state.	TPM physical presence is in asserted state.	<ol style="list-style-type: none"> <li>1. Complete any administrative tasks requiring the TPM physical presence switch to the "ON" position.</li> <li>2. Restore the physical presence switch to the "OFF" position and restart the system.</li> <li>3. (Trained technician only) Replace the system board (see “Removing the system-board assembly” on page 78 and “Installing the system-board assembly” on page 79).</li> </ol>
I.3868000	[I.3868000] BOFM: System reset performed to reset adapters.	BOFM: System reset performed to reset adapters.	No action; information only.
W.3868001	[W.3868001] BOFM: Reset loop avoided - Multiple resets not allowed.	BOFM: Reset loop avoided - Multiple resets not allowed.	<ol style="list-style-type: none"> <li>1. Check the IBM support website for an applicable retain tip or firmware update (including adapters) that applies to this memory error.</li> <li>2. Contact your IBM service representative for support.</li> </ol>
W.3868002	[W.3868002] BOFM: Error communicating with the IMM - BOFM may not be deployed correctly.	BOFM: Error communicating with the IMM - BOFM may not be deployed correctly.	<ol style="list-style-type: none"> <li>1. Check the IBM support website for an applicable retain tip or firmware update (including adapters) that applies to this memory error.</li> <li>2. Contact your IBM service representative for support.</li> </ol>
I.3868003	[I.3868003] BOFM: Configuration too large for compatibility mode.	BOFM: Configuration too large for compatibility mode.	No action; information only.
W.3938002	[W.3938002] A boot configuration error has been detected.	Boot Configuration Error.	<ol style="list-style-type: none"> <li>1. Run the Setup utility (see “Using the Setup utility” on page 11), select <b>Load Default Settings</b>, and save the settings.</li> <li>2. Recover the server firmware (see “Recovering from a UEFI update failure” on page 192).</li> </ol>

## IMM error messages

Use this information to resolve IMM error messages.

The following table lists IMM error messages and suggested actions to correct the detected problems. Deassertive events not listed in this table are informational only.

- Error Code = IMM events displayed by AMM (for example, Service Advisor, AMM web interface)
- Event ID = IMM events displayed by DSA diagnostic program (for example, in the Chassis Event Log section)

- Follow the suggested actions in the order in which they are listed in the Action column until the problem is solved.
- See Chapter 3 “Parts listing” on page 33 to determine which components are consumable, structural, or CRU parts.
- If an action step is preceded by “(Trained technician only),” that step must be performed only by a trained technician.

Error Code	Event ID	Type	Error Message	Action
0x80010200	80010202-0701ffff	Error	System board (SysBrd 3.3V) voltage (lower critical) has asserted.	<ol style="list-style-type: none"> <li>1. Remove all expansion cards from the blade server (see “Removing an I/O expansion card” on page 60).</li> <li>2. Remove all storage drives from the blade server (see “Removing a hot-swap storage drive” on page 53).</li> <li>3. If the error still occurs, replace the system-board assembly (see “Removing the system-board assembly” on page 78 and “Installing the system-board assembly” on page 79).</li> </ol>
0x80010200	80010202-0701ffff	Error	System board (SysBrd 5V) voltage (lower critical) has asserted.	<ol style="list-style-type: none"> <li>1. Remove all expansion cards from the blade server (see “Removing an I/O expansion card” on page 60).</li> <li>2. Remove all storage drives from the blade server (see “Removing a hot-swap storage drive” on page 53).</li> <li>3. If the error still occurs, replace the system-board assembly (see “Removing the system-board assembly” on page 78 and “Installing the system-board assembly” on page 79).</li> </ol>
0x80010200	80010202-0701ffff	Error	System board (SysBrd 12V) voltage (lower critical) has asserted.	<ol style="list-style-type: none"> <li>1. If the under voltage problem is occurring on all blade servers, look for other events in the log related to power and resolve those events (see “Event logs” on page 85).</li> <li>2. View the event log provided by the advanced management module for your BladeCenter unit and resolve any power related errors that might be displayed.</li> <li>3. If other modules or blades are logging the same issue then check the power supply for the BladeCenter unit.</li> <li>4. If the error still occurs, replace the system-board assembly (see “Removing the system-board assembly” on page 78 and “Installing the system-board assembly” on page 79).</li> </ol>



- Follow the suggested actions in the order in which they are listed in the Action column until the problem is solved.
- See Chapter 3 “Parts listing” on page 33 to determine which components are consumable, structural, or CRU parts.
- If an action step is preceded by “(Trained technician only),” that step must be performed only by a trained technician.

Error Code	Event ID	Type	Error Message	Action
0x80010200	80010202-0701ffff	Error	System board (CMOS battery) voltage (lower critical) has asserted.	Replace the system battery (see “Removing the battery” on page 51 and “Installing the battery” on page 51).
0x80010700	80010701-1001ffff 80010701-1002ffff 80010701-1003ffff 80010701-1004ffff	Warning	Expansion Module, (GPU_X TMP) temperature (upper non-critical) has asserted. [Note: X=1-4]	<ol style="list-style-type: none"> <li>1. Check the IBM support website for an applicable retain tip or firmware update that applies to this temperature error.</li> <li>2. Make sure that the room temperature is within the operating specifications (see “Features and specifications” on page 2).</li> <li>3. Make sure that none of the air vents on the BladeCenter unit and on the blade server are blocked.</li> <li>4. Make sure that all of the fans on the BladeCenter unit are running.</li> <li>5. Make sure that each bay of the BladeCenter unit has either a device or a filler installed.</li> <li>6. Make sure that the blade server is not missing any heat sinks, DIMMs, heat-sink fillers, or DIMM fillers (see Chapter 3 “Parts listing” on page 33).</li> <li>7. View the event logs provided by the advanced management module for your BladeCenter unit and resolve any related errors that might be displayed.</li> <li>8. Clear the CMOS data by removing the system battery for 30 seconds (see “Removing the battery” on page 51 and “Installing the battery” on page 51).</li> <li>9. Make sure that the heat sink is properly attached to the microprocessor (see “Installing a microprocessor and heat sink” on page 73).</li> </ol>

- Follow the suggested actions in the order in which they are listed in the Action column until the problem is solved.
- See Chapter 3 “Parts listing” on page 33 to determine which components are consumable, structural, or CRU parts.
- If an action step is preceded by “(Trained technician only),” that step must be performed only by a trained technician.

Error Code	Event ID	Type	Error Message	Action
0x80010700	80010701-2101ffff	Warning	System mgmt software (PCH Temp) temperature (upper non-critical) has asserted.	<ol style="list-style-type: none"> <li>1. Make sure that the room temperature is within the operating specifications (see “Features and specifications” on page 2).</li> <li>2. Make sure that none of the air vents on the BladeCenter unit and on the blade server are blocked.</li> <li>3. Make sure that all of the fans on the BladeCenter unit are running.</li> <li>4. Check the error logs about the temperature and the fan (see “UEFI/POST error codes” on page 88).</li> </ol>
0x80010900	80010901-2101ffff	Error	System mgmt software (PCH Temp) temperature (upper non-critical) has asserted.	<ol style="list-style-type: none"> <li>1. Make sure that the room temperature is within the operating specifications (see “Features and specifications” on page 2).</li> <li>2. Make sure that none of the air vents on the BladeCenter unit and on the blade server are blocked.</li> <li>3. Make sure that all of the fans on the BladeCenter unit are running.</li> <li>4. Check the error logs about the temperature and the fan (see “UEFI/POST error codes” on page 88).</li> </ol>
0x80010900	80010902-0701ffff	Error	System board (SysBrd 3.3V) voltage (upper critical) has asserted.	Replace the blade (see “Removing the system-board assembly” on page 78 and “Installing the system-board assembly” on page 79).
0x80010900	80010902-0701ffff	Error	System board (SysBrd 5V) voltage (upper critical) has asserted.	<ol style="list-style-type: none"> <li>1. Remove all expansion cards from the blade server (see “Removing an I/O expansion card” on page 60).</li> <li>2. Remove all storage drives from the blade server (see “Removing a hot-swap storage drive” on page 53).</li> <li>3. If the error continues, replace the system-board assembly (see “Removing the system-board assembly” on page 78 and “Installing the system-board assembly” on page 79).</li> </ol>

- Follow the suggested actions in the order in which they are listed in the Action column until the problem is solved.
- See Chapter 3 “Parts listing” on page 33 to determine which components are consumable, structural, or CRU parts.
- If an action step is preceded by “(Trained technician only),” that step must be performed only by a trained technician.

Error Code	Event ID	Type	Error Message	Action
0x80010900	80010902-0701ffff	Error	System board (SysBrd 12V) voltage (upper critical) has asserted.	<ol style="list-style-type: none"> <li>1. If the over voltage problem is occurring on all blade servers, look for other events in the log related to power and resolve those events.</li> <li>2. View the event log provided by the advanced management module for your BladeCenter unit and resolve any power related errors that might be displayed.</li> <li>3. If other modules or blades are logging the same issue then check the power supply for the BladeCenter unit.</li> <li>4. If the error continues, replace the system-board assembly (see “Removing the system-board assembly” on page 78 and “Installing the system-board assembly” on page 79).</li> </ol>
0x80010b00	80010b01-1001ffff 80010b01-1002ffff 80010b01-1003ffff 80010b01-1004ffff	Error	Expansion Module, (GPU_X TMP) temperature (upper non-recoverable) has asserted. [Note: X=1-4]	<ol style="list-style-type: none"> <li>1. Check the IBM support website for an applicable retain tip or firmware update that applies to this temperature error.</li> <li>2. Make sure that the room temperature is within the operating specifications (see “Features and specifications” on page 2).</li> <li>3. Make sure that none of the air vents on the BladeCenter unit and on the blade server are blocked.</li> <li>4. Make sure that all of the fans on the BladeCenter unit are running.</li> <li>5. Make sure that each bay of the BladeCenter unit has either a device or a filler installed.</li> <li>6. Make sure that the blade server is not missing any heat sinks, DIMMs, heat-sink fillers, or DIMM fillers (see Chapter 3 “Parts listing” on page 33).</li> <li>7. View the event logs provided by the advanced management module for your BladeCenter unit and resolve any related errors that might be displayed.</li> <li>8. Clear the CMOS data by removing the system battery for 30 seconds (see “Removing the battery” on page 51 and “Installing the battery” on page 51).</li> </ol>

- Follow the suggested actions in the order in which they are listed in the Action column until the problem is solved.
- See Chapter 3 “Parts listing” on page 33 to determine which components are consumable, structural, or CRU parts.
- If an action step is preceded by “(Trained technician only),” that step must be performed only by a trained technician.

Error Code	Event ID	Type	Error Message	Action
				9. Make sure that the heat sink is properly attached to the microprocessor (see “Installing a microprocessor and heat sink” on page 73).
0x80010b00	80010b01-2101ffff	Error	System mgmt software (PCH Temp) temperature (upper non-recoverable) has asserted.	<ol style="list-style-type: none"> <li>1. Make sure that the room temperature is within the operating specifications (see “Features and specifications” on page 2).</li> <li>2. Make sure that none of the air vents on the BladeCenter unit and on the blade server are blocked.</li> <li>3. Make sure that all of the fans on the BladeCenter unit are running.</li> <li>4. Check the error logs about the temperature and the fan (see “UEFI/POST error codes” on page 88).</li> </ol>
0x80030100	80030006-2101ffff	Info	Sensor (Sig Verify Fail) has deasserted.	Information only; no action is required.
0x80030100	8003010e-2581ffff	Info	Sensor (Memory Resized) has asserted.	This is a UEFI detected event. The UEFI diagnostic code for this event can be found in the logged IMM message text. Please refer to “UEFI/POST error codes” on page 88 for the appropriate actions.
0x80030100	8003010f-2101ffff	Info	System mgmt software, firmware progress (Phy Presence Jmp) has occurred.	Information only; no action is required.
0x80030100	80030128-2101ffff	Info	System mgmt software, blade mgmt subsystem health (Low Security Jmp) has occurred.	Information only; no action is required.
0x8006f0021	806f0021-2201ffff	Error	FW/BIOS, connector (No Op ROM Space) PCI express slot X fault. [Note: X=1,2]	This is a UEFI detected event. The UEFI diagnostic code for this event can be found in the logged IMM message text. Please refer to “UEFI/POST error codes” on page 88 for the appropriate actions.

- Follow the suggested actions in the order in which they are listed in the Action column until the problem is solved.
- See Chapter 3 “Parts listing” on page 33 to determine which components are consumable, structural, or CRU parts.
- If an action step is preceded by “(Trained technician only),” that step must be performed only by a trained technician.

Error Code	Event ID	Type	Error Message	Action
0x80070100	80070101-0301ffff 80070101-0302ffff	Warning	Processor X, temperature (CPU X OverTemp) warning [Note: X=1,2]	<ol style="list-style-type: none"> <li>1. Check the system event log for additional temperature and fan information (see “Event logs” on page 85).</li> <li>2. Make sure that the room temperature is within the operating specifications (see “Features and specifications” on page 2).</li> <li>3. Make sure that none of the air vents on the BladeCenter unit and on the blade server are blocked.</li> <li>4. Make sure that all of the fans on the BladeCenter unit are running.</li> <li>5. Make sure that each bay of the BladeCenter unit has either a device or a filler installed.</li> <li>6. Make sure that the blade server is not missing any heat sinks, DIMMs, heat-sink fillers, or DIMM fillers (see Chapter 3 “Parts listing” on page 33).</li> <li>7. Make sure that the CPU heat sink is properly attached to the CPU (see “Installing a microprocessor and heat sink” on page 73).</li> </ol>
0x80070100	80070101-0701ffff	Warning	System board, temperature (Inlet temp) warning	<ol style="list-style-type: none"> <li>1. Make sure that the room temperature is within the operating specifications (see “Features and specifications” on page 2).</li> <li>2. Make sure that none of the air vents on the BladeCenter unit and on the blade server are blocked.</li> <li>3. Make sure that all of the fans on the BladeCenter unit are running.</li> </ol>
0x80070100	80070101-0701ffff	Warning	System board, temperature (VRD Hot) warning	<ol style="list-style-type: none"> <li>1. Make sure that the room temperature is within the operating specifications (see “Features and specifications” on page 2).</li> <li>2. Make sure that none of the air vents on the BladeCenter unit and on the blade server are blocked.</li> <li>3. Make sure that all of the fans on the BladeCenter unit are running.</li> </ol>

- Follow the suggested actions in the order in which they are listed in the Action column until the problem is solved.
- See Chapter 3 “Parts listing” on page 33 to determine which components are consumable, structural, or CRU parts.
- If an action step is preceded by “(Trained technician only),” that step must be performed only by a trained technician.

Error Code	Event ID	Type	Error Message	Action
0x80070100	80070101-1001ffff 80070101-1002ffff 80070101-1003ffff 80070101-1004ffff	Warning	Expansion Module, temperature (BPE4_X TMP) warning. [Note: X=1-4]	<ol style="list-style-type: none"> <li>1. Check the IBM support website for an applicable retain tip or firmware update that applies to this temperature error.</li> <li>2. Make sure that the room temperature is within the operating specifications (see “Features and specifications” on page 2).</li> <li>3. Make sure that none of the air vents on the BladeCenter unit and on the blade server are blocked.</li> <li>4. Make sure that all of the fans on the BladeCenter unit are running.</li> <li>5. Make sure that each bay of the BladeCenter unit has either a device or a filler installed.</li> <li>6. Make sure that the blade server is not missing any heat sinks, DIMMs, heat-sink fillers, or DIMM fillers (see Chapter 3 “Parts listing” on page 33).</li> <li>7. View the event logs provided by the advanced management module for your BladeCenter unit and resolve any related errors that might be displayed.</li> <li>8. Clear the CMOS data by removing the system battery for 30 seconds (see “Removing the battery” on page 51 and “Installing the battery” on page 51).</li> <li>9. Make sure that the heat sink is properly attached to the microprocessor (see “Installing a microprocessor and heat sink” on page 73).</li> </ol>
0x80070100	80070114-2201ffff	Error	FW/BIOS, switch (TPM Lock) warning	This is a UEFI detected event. The UEFI diagnostic code for this event can be found in the logged IMM message text. Please refer to “UEFI/POST error codes” on page 88 for the appropriate actions.

- Follow the suggested actions in the order in which they are listed in the Action column until the problem is solved.
- See Chapter 3 “Parts listing” on page 33 to determine which components are consumable, structural, or CRU parts.
- If an action step is preceded by “(Trained technician only),” that step must be performed only by a trained technician.

Error Code	Event ID	Type	Error Message	Action
0x80070200	80070201-0701ffff	Error	System board, temperature (Inlet temp) critical.	<ol style="list-style-type: none"> <li>1. Make sure that the room temperature is within the operating specifications (see “Features and specifications” on page 2).</li> <li>2. Make sure that none of the air vents on the BladeCenter unit and on the blade server are blocked.</li> <li>3. Make sure that all of the fans on the BladeCenter unit are running.</li> <li>4. Make sure the air baffle and the fan fillers are installed correctly.</li> </ol>
0x80070200	80070201-1001ffff 80070201-1002ffff 80070201-1003ffff 80070201-1004ffff	Error	Expansion Module, temperature (BPE4_X TMP) critical [Note: X=1-4]	<ol style="list-style-type: none"> <li>1. Check the IBM support website for an applicable retain tip or firmware update that applies to this temperature error.</li> <li>2. Make sure that the room temperature is within the operating specifications (see “Features and specifications” on page 2).</li> <li>3. Make sure that none of the air vents on the BladeCenter unit and on the blade server are blocked.</li> <li>4. Make sure that all of the fans on the BladeCenter unit are running.</li> <li>5. Make sure that each bay of the BladeCenter unit has either a device or a filler installed.</li> <li>6. Make sure that the blade server is not missing any heat sinks, DIMMs, heat-sink fillers, or DIMM fillers (see Chapter 3 “Parts listing” on page 33).</li> <li>7. View the event logs provided by the advanced management module for your BladeCenter unit and resolve any related errors that might be displayed.</li> <li>8. Clear the CMOS data by removing the system battery for 30 seconds (see “Removing the battery” on page 51 and “Installing the battery” on page 51).</li> <li>9. Make sure that the heat sink is properly attached to the microprocessor (see “Installing a microprocessor and heat sink” on page 73).</li> </ol>

- Follow the suggested actions in the order in which they are listed in the Action column until the problem is solved.
- See Chapter 3 “Parts listing” on page 33 to determine which components are consumable, structural, or CRU parts.
- If an action step is preceded by “(Trained technician only),” that step must be performed only by a trained technician.

Error Code	Event ID	Type	Error Message	Action
0x80070200	80070202-0701ffff	Error	System board, voltage (SysBrd Vol Fault) critical	<ol style="list-style-type: none"> <li>1. Reseat the blade server in the BladeCenter unit (see “Removing the blade server from the BladeCenter unit” on page 41 and “Installing the blade server in a BladeCenter unit” on page 41).</li> <li>2. If the error continues, replace the system-board assembly (see “Removing the system-board assembly” on page 78 and “Installing the system-board assembly” on page 79).</li> </ol>
0x80070200	80070202-1001ffff 80070202-1002ffff 80070202-1003ffff 80070202-1004ffff	Error	Expansion Module 0 or 2, voltage (BPE4_X_VOL) critical [Note: X=1-4]	<ol style="list-style-type: none"> <li>1. If the under voltage problem is occurring on all blade servers, look for other events in the IMM2 event log related to power and resolve those events (see “Event logs” on page 85).</li> <li>2. View the event log provided by the advanced management module for your BladeCenter unit and resolve any power related errors that might be displayed.</li> <li>3. If other modules or blades are logging the same issue then check the system power supply, otherwise replace the Blade PCI Express I/O expansion unit. See “Removing an optional expansion unit” on page 68 and “Installing an optional expansion unit” on page 69.</li> </ol>
0x80070200	80070217-1001ffff 80070217-1002ffff 80070217-1003ffff 80070217-1004ffff	Error	Expansion Module 0 or 2, Expansion Card (BPE4_X Fault) critical [Note: X=1-4]	<ol style="list-style-type: none"> <li>1. View the event log provided by the advanced management module for your BladeCenter unit and resolve any expansion card related errors that might be displayed.</li> <li>2. If other modules or blades are logging the same issue then check the power supply for the BladeCenter unit.</li> <li>3. If the error still occurs, replace the system-board assembly (see “Removing the system-board assembly” on page 78 and “Installing the system-board assembly” on page 79).</li> </ol>



- Follow the suggested actions in the order in which they are listed in the Action column until the problem is solved.
- See Chapter 3 “Parts listing” on page 33 to determine which components are consumable, structural, or CRU parts.
- If an action step is preceded by “(Trained technician only),” that step must be performed only by a trained technician.

Error Code	Event ID	Type	Error Message	Action
0x80070200	80070219-0701ffff	Error	System board, chip set (SysBrd Fault) critical	<ol style="list-style-type: none"> <li>1. Make sure that the latest firmware is being used (see “Updating firmware and device drivers” on page 23).</li> <li>2. Reseat the blade server in the BladeCenter (see “Removing the blade server from the BladeCenter unit” on page 41 and “Installing the blade server in a BladeCenter unit” on page 41).</li> <li>3. Reset the UEFI firmware settings to default values using the Setup utility (see “Using the Setup utility” on page 11).</li> <li>4. Clear the CMOS data by removing the system battery for 30 seconds (see “Removing the battery” on page 51 and “Installing the battery” on page 51).</li> <li>5. (Trained technician only) Replace the system-board assembly (see “Removing the system-board assembly” on page 78 and “Installing the system-board assembly” on page 79).</li> </ol>
0x80070200	8007021b-0301ffff 8007021b-0302ffff	Error	Processor X, interconnect (CPU X QPILinkErr) critical [Note: X=1,2]	<ol style="list-style-type: none"> <li>1. Check the IBM support website for an applicable retain tip or firmware update that applies to this error.</li> <li>2. (Trained technician only) Reseat the processor (see “Removing a microprocessor and heat sink” on page 70 and “Installing a microprocessor and heat sink” on page 73).</li> <li>3. (Trained technician only) If the error continues, replace the system-board assembly (see “Removing the system-board assembly” on page 78 and “Installing the system-board assembly” on page 79).</li> </ol>

- Follow the suggested actions in the order in which they are listed in the Action column until the problem is solved.
- See Chapter 3 “Parts listing” on page 33 to determine which components are consumable, structural, or CRU parts.
- If an action step is preceded by “(Trained technician only),” that step must be performed only by a trained technician.

Error Code	Event ID	Type	Error Message	Action
0x80070200	8007021b-0301ffff 8007021b-0302ffff	Error	Sensor (CPU X QPILinkErr) critical [Note: X=1,2]	<ol style="list-style-type: none"> <li>1. Check the IBM support website for an applicable retain tip or firmware update that applies to this error.</li> <li>2. (Trained technician only) Reseat the processor (see “Removing a microprocessor and heat sink” on page 70 and “Installing a microprocessor and heat sink” on page 73).</li> <li>3. (Trained technician only) If the error continues, replace the system-board assembly (see “Removing the system-board assembly” on page 78 and “Installing the system-board assembly” on page 79).</li> </ol>
0x80070200	8007020f-2201ffff	Error	FW/BIOS, firmware progress (TXT ACM Module) critical	This is a UEFI detected event. The UEFI diagnostic code for this event can be found in the logged IMM message text. Please refer to “UEFI/POST error codes” on page 88 for the appropriate actions.
0x80070200	8007020f-2582ffff	Error	Group 2, PCI express bus X, Expansion Module 2-0, firmware progress, no I/O resources. [Note: X=1, 2]	This is a UEFI detected event. The UEFI diagnostic code for this event can be found in the logged IMM message text. Please refer to “UEFI/POST error codes” on page 88 for the appropriate actions.
0x80070300	80070301-0301ffff 80070301-0302ffff	Error	Processor X, temperature (CPU X OverTemp) non-recoverable [Note: X=1, 2]	<ol style="list-style-type: none"> <li>1. Check the system event log for additional temperature and fan information (see “Event logs” on page 85).</li> <li>2. Make sure that the room temperature is within the operating specifications (see “Features and specifications” on page 2).</li> <li>3. Make sure that none of the air vents on the BladeCenter unit and on the blade server are blocked.</li> <li>4. Make sure that all of the fans on the BladeCenter unit are running.</li> <li>5. Make sure that each bay of the BladeCenter unit has either a device or a filler installed.</li> <li>6. Make sure that the blade server is not missing any heat sinks, DIMMs, heat-sink fillers, or DIMM fillers (see Chapter 3 “Parts listing” on page 33).</li> </ol>

- Follow the suggested actions in the order in which they are listed in the Action column until the problem is solved.
- See Chapter 3 “Parts listing” on page 33 to determine which components are consumable, structural, or CRU parts.
- If an action step is preceded by “(Trained technician only),” that step must be performed only by a trained technician.

Error Code	Event ID	Type	Error Message	Action
				7. Make sure that the CPU heat sink is properly attached to the CPU (see “Installing a microprocessor and heat sink” on page 73).
0x80070300	80070301-0701ffff	Error	System board, temperature (Inlet temp) non-recoverable.	<ol style="list-style-type: none"> <li>1. Make sure that the room temperature is within the operating specifications (see “Features and specifications” on page 2).</li> <li>2. Make sure that none of the air vents on the BladeCenter unit and on the blade server are blocked.</li> <li>3. Make sure that all of the fans on the BladeCenter unit are running.</li> </ol>
0x80070300	80070301-1001ffff 80070301-1002ffff 80070301-1003ffff 80070301-1004ffff	Error	Expansion Module, temperature (BPE4_X_TMP) non-recoverable [Note: X=1-4]	<ol style="list-style-type: none"> <li>1. Check the IBM support website for an applicable retain tip or firmware update that applies to this temperature error.</li> <li>2. Make sure that the room temperature is within the operating specifications (see “Features and specifications” on page 2).</li> <li>3. Make sure that none of the air vents on the BladeCenter unit and on the blade server are blocked.</li> <li>4. Make sure that all of the fans on the BladeCenter unit are running.</li> <li>5. Make sure that each bay of the BladeCenter unit has either a device or a filler installed.</li> <li>6. Make sure that the blade server is not missing any heat sinks, DIMMs, heat-sink fillers, or DIMM fillers (see Chapter 3 “Parts listing” on page 33).</li> <li>7. View the event logs provided by the advanced management module for your BladeCenter unit and resolve any related errors that might be displayed.</li> <li>8. Clear the CMOS data by removing the system battery for 30 seconds (see “Removing the battery” on page 51 and “Installing the battery” on page 51).</li> <li>9. Make sure that the heat sink is properly attached to the microprocessor (see “Installing a microprocessor and heat sink” on page 73).</li> </ol>

- Follow the suggested actions in the order in which they are listed in the Action column until the problem is solved.
- See Chapter 3 “Parts listing” on page 33 to determine which components are consumable, structural, or CRU parts.
- If an action step is preceded by “(Trained technician only),” that step must be performed only by a trained technician.

Error Code	Event ID	Type	Error Message	Action
0x80070300	80070302-1001ffff 80070302-1002ffff 80070302-1003ffff 80070302-1004ffff	Error	Expansion Module, voltage (BPE4_X_VOL) non-recoverable [Note: X=1-4]	<ol style="list-style-type: none"> <li>1. If the under voltage problem is occurring on all blade servers, look for other events in the IMM2 event log related to power and resolve those events (see “Event logs” on page 85).</li> <li>2. View the event log provided by the advanced management module for your BladeCenter unit and resolve any power related errors that might be displayed.</li> <li>3. If other modules or blades are logging the same issue then check the system power supply, otherwise replace the Blade PCI Express I/O expansion unit. See “Removing an optional expansion unit” on page 68 and “Installing an optional expansion unit” on page 69.</li> </ol>
0x80070600	8007060f-2201ffff	Error	FW/BIOS, firmware progress (BOFM cfg Err) non-recoverable	Install the latest UEFI firmware (see “Updating firmware and device drivers” on page 23).
0x80070600	8007060f-2201ffff	Error	FW/BIOS, firmware progress (TPM Init Err) non-recoverable	Install the latest UEFI firmware (see “Updating firmware and device drivers” on page 23).
0x800b0100	800b010c-2581ffff	Error	Redundancy Lost for (Backup Memory) has asserted.	<ol style="list-style-type: none"> <li>1. Check the event logs for other memory errors that might occur (see “Event logs” on page 85).</li> <li>2. Reseat all of the memory modules in the blade server (see “Removing a memory module” on page 54 and “Installing a memory module” on page 55).</li> <li>3. Make sure all of the memory is enabled in the Setup utility (see “Using the Setup utility” on page 11). Notice which memory modules are disabled before continuing to the next step.</li> </ol>

- Follow the suggested actions in the order in which they are listed in the Action column until the problem is solved.
- See Chapter 3 “Parts listing” on page 33 to determine which components are consumable, structural, or CRU parts.
- If an action step is preceded by “(Trained technician only),” that step must be performed only by a trained technician.

Error Code	Event ID	Type	Error Message	Action
0x800b0300	800b030c-2581ffff	Warning	Non-redundant: Sufficient Resources from Redundancy Degraded or Fully Redundant for (Backup Memory) has asserted.	<ol style="list-style-type: none"> <li>1. Check the event logs for other memory errors that might occur (see “Event logs” on page 85).</li> <li>2. Reseat all of the memory modules in the blade server (see “Removing a memory module” on page 54 and “Installing a memory module” on page 55).</li> <li>3. Make sure all of the memory is enabled in the Setup utility (see “Using the Setup utility” on page 11). Notice which memory modules are disabled before continuing to the next step.</li> </ol>
0x800b0500	800b050c-2581ffff	Error	Non-redundant: Insufficient Resources for (Backup Memory) has asserted.	<ol style="list-style-type: none"> <li>1. Check the event logs for other memory errors that might occur (see “Event logs” on page 85).</li> <li>2. Reseat all of the memory modules in the blade server (see “Removing a memory module” on page 54 and “Installing a memory module” on page 55).</li> <li>3. Make sure all of the memory is enabled in the Setup utility (see “Using the Setup utility” on page 11). Notice which memory modules are disabled before continuing to the next step.</li> </ol>
0x806f0007	806f0007-0301ffff 806f0007-0302ffff	Error	Processor X (CPU X) has Failed with IERR. [Note X=1,2]	<ol style="list-style-type: none"> <li>1. Remove the blade server and ensure the processors are installed correctly (see “Installing a microprocessor and heat sink” on page 73).</li> <li>2. Verify that the system is running the latest UEFI firmware (see “Updating firmware and device drivers” on page 23).</li> <li>3. Run the Setup utility (see “Using the Setup utility” on page 11). <ol style="list-style-type: none"> <li>a. Make sure that both processors are displayed by the system.</li> <li>b. Load the default settings.</li> <li>c. Go to the <b>System Settings</b> menu and make sure the processor is enabled.</li> </ol> </li> <li>4. (Trained technician only) If the problem continues, replace the processor (see “Removing a microprocessor and heat sink” on page 70 and “Installing</li> </ol>

- Follow the suggested actions in the order in which they are listed in the Action column until the problem is solved.
- See Chapter 3 “Parts listing” on page 33 to determine which components are consumable, structural, or CRU parts.
- If an action step is preceded by “(Trained technician only),” that step must be performed only by a trained technician.

Error Code	Event ID	Type	Error Message	Action
				a microprocessor and heat sink” on page 73). 5. (Trained technician only) If the error continues, replace the system-board assembly (see “Removing the system-board assembly” on page 78 and “Installing the system-board assembly” on page 79).
0x806f0009	806f0009-1301ffff	Info	Sensor (Host Power) has been turned off.	Information only; no action is required.
0x806f000d	806f000d-0400ffff 806f000d-0401ffff	Error	Hard drive X, (Drive X) removed [Note X=0,1]	Install the storage drive (see “Installing a hot-swap storage drive” on page 53).
0x806f000f	806f000f-220101xx	Error	FW/BIOS, firmware error. The System (ABR Status) has detected no memory in the system.	Install the latest UEFI firmware (see “Recovering from a UEFI update failure” on page 192).
0x806f000f	806f000f-220102xx	Error	FW/BIOS, firmware error. Subsystem (ABR Status) has insufficient memory for operation.	Install the latest UEFI firmware (see “Recovering from a UEFI update failure” on page 192).
0x806f000f	806f000f-220103xx	Error	FW/BIOS, firmware error. The System (ABR Status) encountered firmware error - unrecoverable boot device failure.	This is a UEFI detected event. The UEFI diagnostic code for this event can be found in the logged IMM message text. Please refer to “UEFI/POST error codes” on page 88 for the appropriate actions.
0x806f000f	806f000f-220104xx	Error	FW/BIOS, firmware error. The System (ABR Status) has encountered a motherboard failure.	This is a UEFI detected event. The UEFI diagnostic code for this event can be found in the logged IMM message text. Please refer to “UEFI/POST error codes” on page 88 for the appropriate actions.

- Follow the suggested actions in the order in which they are listed in the Action column until the problem is solved.
- See Chapter 3 “Parts listing” on page 33 to determine which components are consumable, structural, or CRU parts.
- If an action step is preceded by “(Trained technician only),” that step must be performed only by a trained technician.

Error Code	Event ID	Type	Error Message	Action
0x806f000f	806f000f-220107xx	Error	FW/BIOS, firmware error. The System (ABR Status) encountered firmware error - unrecoverable keyboard failure.	This is a UEFI detected event. The UEFI diagnostic code for this event can be found in the logged IMM message text. Please refer to “UEFI/POST error codes” on page 88 for the appropriate actions.
0x806f000f	806f000f-22010axx	Error	FW/BIOS, firmware error. The System (ABR Status) encountered firmware error - no video device detected.	This is a UEFI detected event. The UEFI diagnostic code for this event can be found in the logged IMM message text. Please refer to “UEFI/POST error codes” on page 88 for the appropriate actions.
0x806f000f	806f000f-22010bxx	Error	Firmware BIOS (ROM) corruption was detected on system (ABR Status) during POST.	This is a UEFI detected event. The UEFI diagnostic code for this event can be found in the logged IMM message text. Please refer to “UEFI/POST error codes” on page 88 for the appropriate actions.
0x806f000f	806f000f-22010cxx	Error	CPU voltage mismatch detected on (ABR Status).	This is a UEFI detected event. The UEFI diagnostic code for this event can be found in the logged IMM message text. Please refer to “UEFI/POST error codes” on page 88 for the appropriate actions.
0x806f000f	806f000f-2201ffff	Error	The System (ABR Status) encountered a POST Error.	This is a UEFI detected event. The UEFI diagnostic code for this event can be found in the logged IMM message text. Please refer to “UEFI/POST error codes” on page 88 for the appropriate actions.
0x806f0013	806f0013-1701ffff	Info	A diagnostic interrupt has occurred on system (NMI State).	<ol style="list-style-type: none"> <li>1. Verify that you have the latest system firmware (see “Updating firmware and device drivers” on page 23).</li> <li>2. If an expansion card is installed in the blade server, verify that the firmware for each expansion card is up to date.</li> <li>3. Run the Setup utility and restore system setting to defaults (see “Using the Setup utility” on page 11).</li> <li>4. Check the event logs for other related error messages (see “Event logs” on page 85).</li> <li>5. Remove each expansion card, one at a time until the error does not occur (see “Removing an I/O expansion card” on page 60).</li> </ol>

- Follow the suggested actions in the order in which they are listed in the Action column until the problem is solved.
- See Chapter 3 “Parts listing” on page 33 to determine which components are consumable, structural, or CRU parts.
- If an action step is preceded by “(Trained technician only),” that step must be performed only by a trained technician.

Error Code	Event ID	Type	Error Message	Action
				<ol style="list-style-type: none"> <li>6. Replace failing adapter and reinstall any other expansion cards that were removed (see “Installing an I/O expansion card” on page 62).</li> <li>7. (Trained technician only) If the error continues, replace the system-board assembly (see “Removing the system-board assembly” on page 78 and “Installing the system-board assembly” on page 79).</li> </ol>
0x806f0107	806f0021-1001ffff 806f0021-1002ffff 806f0021-1003ffff 806f0021-1004ffff	Error	Expansion Module, Fault in (Slot Y) on (BPE4_X, [Note: X=1-4, Y=1, 2])	<ol style="list-style-type: none"> <li>1. Check the event logs for other related error messages (see “Event logs” on page 85).</li> <li>2. Verify that you have the latest system firmware (see “Updating firmware and device drivers” on page 23).</li> <li>3. Run the Setup utility and restore system setting to defaults (see “Using the Setup utility” on page 11).</li> <li>4. Check the event logs for other related error messages (see “Event logs” on page 85).</li> <li>5. Reseat the expansion cards and PCIe adapters that are installed in the blade server (see “Removing an I/O expansion card” on page 60 and “Installing an I/O expansion card” on page 62).</li> <li>6. Reseat the expansion unit.</li> <li>7. Remove each expansion card, one at a time until the error does not occur (see “Removing an I/O expansion card” on page 60).</li> <li>8. Replace failing adapter and reinstall any other expansion cards that were removed (see “Installing an I/O expansion card” on page 62).</li> <li>9. Replace the expansion unit (see “Removing an optional expansion unit” on page 68 and “Installing an optional expansion unit” on page 69).</li> <li>10. If the system contains multiple microprocessors, swap the microprocessors (see “Removing a microprocessor and heat sink” on page 70 and “Installing a</li> </ol>



- Follow the suggested actions in the order in which they are listed in the Action column until the problem is solved.
- See Chapter 3 “Parts listing” on page 33 to determine which components are consumable, structural, or CRU parts.
- If an action step is preceded by “(Trained technician only),” that step must be performed only by a trained technician.

Error Code	Event ID	Type	Error Message	Action
				microprocessor and heat sink” on page 73). 11. (Trained technician only) If the error continues, replace the system-board assembly (see “Removing the system-board assembly” on page 78 and “Installing the system-board assembly” on page 79).
0x806f0021	806f0021-2582ffff	Error	PCI error (All PCI Error)	This is a UEFI detected event. The UEFI diagnostic code for this event can be found in the logged IMM message text. Please refer to “UEFI/POST error codes” on page 88 for the appropriate actions.
0x806f0021	806f0021-2582ffff	Error	PCI error (One of PCI Error)	This is a UEFI detected event. The UEFI diagnostic code for this event can be found in the logged IMM message text. Please refer to “UEFI/POST error codes” on page 88 for the appropriate actions.
0x806f0021	806f0021-3101ffff	Error	PCI error (CIOv_STATUS)	<ol style="list-style-type: none"> <li>1. Check the operating system event log and the system event log as it may contain additional information (see “Event logs” on page 85).</li> <li>2. Reseat the blade server in the BladeCenter (see “Removing the blade server from the BladeCenter unit” on page 41 and “Installing the blade server in a BladeCenter unit” on page 41).</li> <li>3. Update the device drivers for any expansion cards that are installed into the blade server.</li> <li>4. Reseat the expansion card (see “Removing an I/O expansion card” on page 60 and “Installing an I/O expansion card” on page 62).</li> <li>5. Replace the expansion card (see “Removing an I/O expansion card” on page 60 and “Installing an I/O expansion card” on page 62).</li> </ol>

- Follow the suggested actions in the order in which they are listed in the Action column until the problem is solved.
- See Chapter 3 “Parts listing” on page 33 to determine which components are consumable, structural, or CRU parts.
- If an action step is preceded by “(Trained technician only),” that step must be performed only by a trained technician.

Error Code	Event ID	Type	Error Message	Action
0x806f0021	806f0021-3102ffff	Error	PCI error (CFFh_STATUS)	<ol style="list-style-type: none"> <li>1. Check the operating system event log and the system event log as it may contain additional information (see “Event logs” on page 85).</li> <li>2. Reseat the blade server in the BladeCenter (see “Removing the blade server from the BladeCenter unit” on page 41 and “Installing the blade server in a BladeCenter unit” on page 41).</li> <li>3. Update the device drivers for any expansion cards that are installed into the blade server.</li> <li>4. Reseat the expansion card (see “Removing an I/O expansion card” on page 60 and “Installing an I/O expansion card” on page 62).</li> <li>5. Replace the expansion card (see “Removing an I/O expansion card” on page 60 and “Installing an I/O expansion card” on page 62).</li> </ol>
	806f0023-2101ffff	Info	Watchdog Timer expired for sensor (IPMI Watchdog).	Information only; no action is required.
0x806f0028	806f0028-2101ffff	Warning	Sensor (TPM Cmd Failures) is unavailable or degraded on management system.	<ol style="list-style-type: none"> <li>1. Restart the server.</li> <li>2. If the problem remains, or the server cannot be restarted successfully, (trained technician only) replace the system board (see “Removing the system-board assembly” on page 78 and “Installing the system-board assembly” on page 79).</li> </ol>
0x806f0107	806f0107-0301ffff 806f0107-0302ffff	Error	Processor X (CPU X) Over-Temperature Condition has been detected. [Note: X=1,2]	<ol style="list-style-type: none"> <li>1. Make sure that the room temperature is within the operating specifications (see “Features and specifications” on page 2).</li> <li>2. Make sure that none of the air vents on the BladeCenter unit and on the blade server are blocked.</li> <li>3. Make sure that all of the fans on the BladeCenter unit are running.</li> <li>4. Make sure that each bay of the BladeCenter unit has either a device or a filler installed.</li> <li>5. Make sure that the blade server is not missing any heat sinks, DIMMs,</li> </ol>

- Follow the suggested actions in the order in which they are listed in the Action column until the problem is solved.
- See Chapter 3 “Parts listing” on page 33 to determine which components are consumable, structural, or CRU parts.
- If an action step is preceded by “(Trained technician only),” that step must be performed only by a trained technician.

Error Code	Event ID	Type	Error Message	Action
				<p>heat-sink fillers, or DIMM fillers (see Chapter 3 “Parts listing” on page 33).</p> <p>6. Make sure that the CPU heat sink is properly attached to the CPU (see “Installing a microprocessor and heat sink” on page 73).</p> <p>7. (Trained technician only) If the error still occurs, replace the microprocessor that controls the failing memory module. See “Removing a microprocessor and heat sink” on page 70 and “Installing a microprocessor and heat sink” on page 73.</p>
0x806f0108	806f0108-0701ffff	Error	System board, Power Module (VRD Fault) failure (VRD Fault) power supply failure detected.	<ol style="list-style-type: none"> <li>1. Make sure that the latest firmware is being used (see “Updating firmware and device drivers” on page 23).</li> <li>2. Reseat the blade server in the BladeCenter (see “Removing the blade server from the BladeCenter unit” on page 41 and “Installing the blade server in a BladeCenter unit” on page 41).</li> <li>3. Reset the UEFI firmware settings to default values using the Setup utility (see “Using the Setup utility” on page 11).</li> <li>4. (Trained technician only) Replace the system-board assembly (see “Removing the system-board assembly” on page 78 and “Installing the system-board assembly” on page 79).</li> </ol>
0x806f0109	806f0109-1301ffff	Info	(Host Power) has been Power Cycled.	Information only; no action is required.

- Follow the suggested actions in the order in which they are listed in the Action column until the problem is solved.
- See Chapter 3 “Parts listing” on page 33 to determine which components are consumable, structural, or CRU parts.
- If an action step is preceded by “(Trained technician only),” that step must be performed only by a trained technician.

Error Code	Event ID	Type	Error Message	Action
0x806f010c	806f010c-2001ffff 806f010c-2002ffff 806f010c-2003ffff 806f010c-2004ffff 806f010c-2005ffff 806f010c-2006ffff 806f010c-2007ffff 806f010c-2008ffff 806f010c-2009ffff 806f010c-200affff 806f010c-200bffff 806f010c-200cffff	Error	Memory device X (DIMM X) uncorrectable ECC memory error [Note: X=1-12]	<ol style="list-style-type: none"> <li>1. Refer to TIP H21455 for minimum code level.</li> <li>2. Check the IBM support website for an applicable retain tip or firmware update that applies to this memory error.</li> <li>3. Install the affected memory modules (as indicated by the error LEDs on the system board or the event logs) to a different memory channel or microprocessor (see “Installing a memory module” on page 55 for memory population sequence).</li> <li>4. If the error still occurs on the same memory module, replace the affected memory module.</li> <li>5. (Trained technician only) If the problem occurs on the same DIMM connector, check the DIMM connector. If the connector is damaged, replace the system-board assembly (see “Removing the system-board assembly” on page 78 and “Installing the system-board assembly” on page 79).</li> <li>6. (Trained technician only) Remove the affected microprocessor and check the microprocessor socket pins for any damaged pins. If a damage is found, replace the system-board assembly (see “Removing the system-board assembly” on page 78 and “Installing the system-board assembly” on page 79).</li> <li>7. (Trained technician only) Replace the affected microprocessor (See “Removing a microprocessor and heat sink” on page 70 and “Installing a microprocessor and heat sink” on page 73).</li> </ol>

- Follow the suggested actions in the order in which they are listed in the Action column until the problem is solved.
- See Chapter 3 “Parts listing” on page 33 to determine which components are consumable, structural, or CRU parts.
- If an action step is preceded by “(Trained technician only),” that step must be performed only by a trained technician.

Error Code	Event ID	Type	Error Message	Action
0x806f010c	806f010c-2581ffff	Error	Sensor (All DIMMs) uncorrectable ECC memory error.	<ol style="list-style-type: none"> <li>1. Refer to TIP H21455 for minimum code level.</li> <li>2. Check the IBM support website for an applicable retain tip or firmware update that applies to this memory error.</li> <li>3. Install the affected memory modules (as indicated by the error LEDs on the system board or the event logs) to a different memory channel or microprocessor (see “Installing a memory module” on page 55 for memory population sequence).</li> <li>4. If the error still occurs on the same memory module, replace the affected memory module.</li> <li>5. (Trained technician only) If the problem occurs on the same DIMM connector, check the DIMM connector. If the connector is damaged, replace the system-board assembly (see “Removing the system-board assembly” on page 78 and “Installing the system-board assembly” on page 79).</li> <li>6. (Trained technician only) Remove the affected microprocessor and check the microprocessor socket pins for any damaged pins. If a damage is found, replace the system-board assembly (see “Removing the system-board assembly” on page 78 and “Installing the system-board assembly” on page 79).</li> <li>7. (Trained technician only) Replace the affected microprocessor (See “Removing a microprocessor and heat sink” on page 70 and “Installing a microprocessor and heat sink” on page 73).</li> </ol>

- Follow the suggested actions in the order in which they are listed in the Action column until the problem is solved.
- See Chapter 3 “Parts listing” on page 33 to determine which components are consumable, structural, or CRU parts.
- If an action step is preceded by “(Trained technician only),” that step must be performed only by a trained technician.

Error Code	Event ID	Type	Error Message	Action
0x806f010c	806f010c-2581ffff	Error	Sensor (One of the DIMMs) uncorrectable ECC memory error.	<ol style="list-style-type: none"> <li>1. Refer to TIP H21455 for minimum code level.</li> <li>2. Check the IBM support website for an applicable retain tip or firmware update that applies to this memory error.</li> <li>3. Install the affected memory modules (as indicated by the error LEDs on the system board or the event logs) to a different memory channel or microprocessor (see “Installing a memory module” on page 55 for memory population sequence).</li> <li>4. If the error still occurs on the same memory module, replace the affected memory module.</li> <li>5. (Trained technician only) If the problem occurs on the same DIMM connector, check the DIMM connector. If the connector is damaged, replace the system-board assembly (see “Removing the system-board assembly” on page 78 and “Installing the system-board assembly” on page 79).</li> <li>6. (Trained technician only) Remove the affected microprocessor and check the microprocessor socket pins for any damaged pins. If a damage is found, replace the system-board assembly (see “Removing the system-board assembly” on page 78 and “Installing the system-board assembly” on page 79).</li> <li>7. (Trained technician only) Replace the affected microprocessor (See “Removing a microprocessor and heat sink” on page 70 and “Installing a microprocessor and heat sink” on page 73).</li> </ol>
0x806f010d	806f010d-0400ffff 806f010d-0401ffff	Error	Hard drive X (Drive X) has been disabled due to a detected fault. [Note: X=0,1]	Replace the storage drive (see “Removing a hot-swap storage drive” on page 53 and “Installing a hot-swap storage drive” on page 53).

- Follow the suggested actions in the order in which they are listed in the Action column until the problem is solved.
- See Chapter 3 “Parts listing” on page 33 to determine which components are consumable, structural, or CRU parts.
- If an action step is preceded by “(Trained technician only),” that step must be performed only by a trained technician.

Error Code	Event ID	Type	Error Message	Action
0x806f010f	806f010f-2201ffff	Error	The system encountered a firmware (Firmware Error) hang	Install the latest UEFI firmware (see “Recovering from a UEFI update failure” on page 192).
0x806f011b	806f011b-0c01ffff	Error	The connector (Front Panel) has encountered a configuration error.	<ol style="list-style-type: none"> <li>1. Reseat the control-panel cable (see “Removing the control panel” on page 66 and “Installing the control panel” on page 67).</li> <li>2. Replace the front bezel (see “Removing the bezel assembly” on page 45 and “Installing the bezel assembly” on page 46).</li> <li>3. (Trained technician only) Replace the system-board assembly (see “Removing the system-board assembly” on page 78 and “Installing the system-board assembly” on page 79).</li> </ol>
	806f0123-2101ffff	Info	Reboot of system initiated by IPMI Watchdog.	Information only; no action is required.
0x806f0207	806f0207-0301ffff 806f0207-0302ffff	Error	Processor X, (CPU X) has failed with FRB1/BIST condition. [Note: X=1,2]	<ol style="list-style-type: none"> <li>1. Remove the blade server and ensure the processors are installed correctly (see “Installing a microprocessor and heat sink” on page 73).</li> <li>2. Verify that the system is running the latest UEFI firmware (see “Updating firmware and device drivers” on page 23).</li> <li>3. Run the Setup utility (see “Using the Setup utility” on page 11). <ol style="list-style-type: none"> <li>a. Make sure that both processors are displayed by the system.</li> <li>b. Load the default settings.</li> <li>c. Go to the <b>System Settings</b> menu and make sure the processor is enabled.</li> </ol> </li> <li>4. (Trained technician only) If the problem continues, replace the processor (see “Removing a microprocessor and heat sink” on page 70 and “Installing a microprocessor and heat sink” on page 73).</li> <li>5. (Trained technician only) If the error continues, replace the system-board assembly (see “Removing the</li> </ol>

- Follow the suggested actions in the order in which they are listed in the Action column until the problem is solved.
- See Chapter 3 “Parts listing” on page 33 to determine which components are consumable, structural, or CRU parts.
- If an action step is preceded by “(Trained technician only),” that step must be performed only by a trained technician.

Error Code	Event ID	Type	Error Message	Action
				system-board assembly” on page 78 and “Installing the system-board assembly” on page 79).
0x806f0207	806f0207-2584ffff	Error	Processor X (All CPUs) has failed with FRB1/BIST condition. [Note: X=1,2]	<ol style="list-style-type: none"> <li>1. Remove the blade server and ensure the processors are installed correctly (see “Installing a microprocessor and heat sink” on page 73).</li> <li>2. Verify that the system is running the latest UEFI firmware (see “Updating firmware and device drivers” on page 23).</li> <li>3. Run the Setup utility (see “Using the Setup utility” on page 11). <ol style="list-style-type: none"> <li>a. Make sure that both processors are displayed by the system.</li> <li>b. Load the default settings.</li> <li>c. Go to the <b>System Settings</b> menu and make sure the processor is enabled.</li> </ol> </li> <li>4. Clear the CMOS data by removing the system battery for 30 seconds (see “Removing the battery” on page 51 and “Installing the battery” on page 51).</li> <li>5. If the problem continues, replace the processor (see “Removing a microprocessor and heat sink” on page 70 and “Installing a microprocessor and heat sink” on page 73).</li> <li>6. (Trained technician only) If the error continues, replace the system-board assembly (see “Removing the system-board assembly” on page 78 and “Installing the system-board assembly” on page 79).</li> </ol>



- Follow the suggested actions in the order in which they are listed in the Action column until the problem is solved.
- See Chapter 3 “Parts listing” on page 33 to determine which components are consumable, structural, or CRU parts.
- If an action step is preceded by “(Trained technician only),” that step must be performed only by a trained technician.

Error Code	Event ID	Type	Error Message	Action
0x806f0207	806f0207-2584ffff	Error	Processor X (One of CPUs) has failed with FRB1/BIST condition. [Note: X=1,2]	<ol style="list-style-type: none"> <li>1. Remove the blade server and ensure the processors are installed correctly (see “Installing a microprocessor and heat sink” on page 73).</li> <li>2. Verify that the system is running the latest UEFI firmware (see “Updating firmware and device drivers” on page 23).</li> <li>3. Run the Setup utility (see “Using the Setup utility” on page 11). <ol style="list-style-type: none"> <li>a. Make sure that both processors are displayed by the system.</li> <li>b. Load the default settings.</li> <li>c. Go to the <b>System Settings</b> menu and make sure the processor is enabled.</li> </ol> </li> <li>4. If the problem continues, replace the processor (see “Removing a microprocessor and heat sink” on page 70 and “Installing a microprocessor and heat sink” on page 73).</li> <li>5. (Trained technician only) If the error continues, replace the system-board assembly (see “Removing the system-board assembly” on page 78 and “Installing the system-board assembly” on page 79).</li> </ol>
0x806f020d	806f020d-0400ffff 806f020d-0401ffff	Warning	Hard drive X (Drive X) predictive failure [Note X=0,1]	Replace the storage drive (see “Removing a hot-swap storage drive” on page 53 and “Installing a hot-swap storage drive” on page 53).
	806f0223-2101ffff	Info	Powering off system initiated by IPMI Watchdog.	Information only; no action is required.

- Follow the suggested actions in the order in which they are listed in the Action column until the problem is solved.
- See Chapter 3 “Parts listing” on page 33 to determine which components are consumable, structural, or CRU parts.
- If an action step is preceded by “(Trained technician only),” that step must be performed only by a trained technician.

Error Code	Event ID	Type	Error Message	Action
0x806f030c	806f030c-2001ffff 806f030c-2002ffff 806f030c-2003ffff 806f030c-2004ffff 806f030c-2005ffff 806f030c-2006ffff 806f030c-2007ffff 806f030c-2008ffff 806f030c-2009ffff 806f030c-200affff 806f030c-200bffff 806f030c-200cffff	Error	Memory device X (DIMM X) memory scrub failed [Note: X=1-12]	<ol style="list-style-type: none"> <li>1. Refer to TIP H21455 for minimum code level.</li> <li>2. Check the IBM support website for an applicable retain tip or firmware update that applies to this memory error.</li> <li>3. Install the affected memory modules (as indicated by the error LEDs on the system board or the event logs) to a different memory channel or microprocessor (see “Installing a memory module” on page 55 for memory population sequence).</li> <li>4. If the error still occurs on the same memory module, replace the affected memory module.</li> <li>5. (Trained technician only) If the problem occurs on the same DIMM connector, check the DIMM connector. If the connector is damaged, replace the system-board assembly (see “Removing the system-board assembly” on page 78 and “Installing the system-board assembly” on page 79).</li> <li>6. (Trained technician only) Remove the affected microprocessor and check the microprocessor socket pins for any damaged pins. If a damage is found, replace the system-board assembly (see “Removing the system-board assembly” on page 78 and “Installing the system-board assembly” on page 79).</li> <li>7. (Trained technician only) Replace the affected microprocessor (See “Removing a microprocessor and heat sink” on page 70 and “Installing a microprocessor and heat sink” on page 73).</li> </ol>

- Follow the suggested actions in the order in which they are listed in the Action column until the problem is solved.
- See Chapter 3 “Parts listing” on page 33 to determine which components are consumable, structural, or CRU parts.
- If an action step is preceded by “(Trained technician only),” that step must be performed only by a trained technician.

Error Code	Event ID	Type	Error Message	Action
0x806f030c	806f030c-2581ffff	Error	Memory device (All DIMMS) memory scrub failed.	<ol style="list-style-type: none"> <li>1. Refer to TIP H21455 for minimum code level.</li> <li>2. Check the IBM support website for an applicable retain tip or firmware update that applies to this memory error.</li> <li>3. Install the affected memory modules (as indicated by the error LEDs on the system board or the event logs) to a different memory channel or microprocessor (see “Installing a memory module” on page 55 for memory population sequence).</li> <li>4. If the error still occurs on the same memory module, replace the affected memory module.</li> <li>5. (Trained technician only) If the problem occurs on the same DIMM connector, check the DIMM connector. If the connector is damaged, replace the system-board assembly (see “Removing the system-board assembly” on page 78 and “Installing the system-board assembly” on page 79).</li> <li>6. (Trained technician only) Remove the affected microprocessor and check the microprocessor socket pins for any damaged pins. If a damage is found, replace the system-board assembly (see “Removing the system-board assembly” on page 78 and “Installing the system-board assembly” on page 79).</li> <li>7. (Trained technician only) Replace the affected microprocessor (See “Removing a microprocessor and heat sink” on page 70 and “Installing a microprocessor and heat sink” on page 73).</li> </ol>

- Follow the suggested actions in the order in which they are listed in the Action column until the problem is solved.
- See Chapter 3 “Parts listing” on page 33 to determine which components are consumable, structural, or CRU parts.
- If an action step is preceded by “(Trained technician only),” that step must be performed only by a trained technician.

Error Code	Event ID	Type	Error Message	Action
0x806f030c	806f030c-2581ffff	Error	Memory device (One of the DIMMS) memory scrub failed.	<ol style="list-style-type: none"> <li>1. Refer to TIP H21455 for minimum code level.</li> <li>2. Check the IBM support website for an applicable retain tip or firmware update that applies to this memory error.</li> <li>3. Install the affected memory modules (as indicated by the error LEDs on the system board or the event logs) to a different memory channel or microprocessor (see “Installing a memory module” on page 55 for memory population sequence).</li> <li>4. If the error still occurs on the same memory module, replace the affected memory module.</li> <li>5. (Trained technician only) If the problem occurs on the same DIMM connector, check the DIMM connector. If the connector is damaged, replace the system-board assembly (see “Removing the system-board assembly” on page 78 and “Installing the system-board assembly” on page 79).</li> <li>6. (Trained technician only) Remove the affected microprocessor and check the microprocessor socket pins for any damaged pins. If a damage is found, replace the system-board assembly (see “Removing the system-board assembly” on page 78 and “Installing the system-board assembly” on page 79).</li> <li>7. (Trained technician only) Replace the affected microprocessor (See “Removing a microprocessor and heat sink” on page 70 and “Installing a microprocessor and heat sink” on page 73).</li> </ol>

- Follow the suggested actions in the order in which they are listed in the Action column until the problem is solved.
- See Chapter 3 “Parts listing” on page 33 to determine which components are consumable, structural, or CRU parts.
- If an action step is preceded by “(Trained technician only),” that step must be performed only by a trained technician.

Error Code	Event ID	Type	Error Message	Action
0x806f0313	806f0313-1701ffff	Error	A software NMI has occurred on system (NMI State).	<ol style="list-style-type: none"> <li>1. Verify that you have the latest system firmware (see “Updating firmware and device drivers” on page 23).</li> <li>2. If an expansion card is installed in the blade server, verify that the firmware for each expansion card is up to date.</li> <li>3. Run the Setup utility and restore system setting to defaults (see “Using the Setup utility” on page 11).</li> <li>4. Check the event logs for other related error messages (see “Event logs” on page 85).</li> <li>5. Reseat any expansion cards that are installed in the blade server (see “Removing an I/O expansion card” on page 60 and “Installing an I/O expansion card” on page 62).</li> <li>6. Remove each expansion card, one at a time until the error does not occur (see “Removing an I/O expansion card” on page 60).</li> <li>7. Replace failing adapter and reinstall any other expansion cards that were removed (see “Installing an I/O expansion card” on page 62).</li> <li>8. (Trained technician only) If the error continues, replace the system-board assembly (see “Removing the system-board assembly” on page 78 and “Installing the system-board assembly” on page 79).</li> </ol>
	806f0323-2101ffff	Info	Power cycle of system initiated by watchdog IPMI Watchdog.	Information only; no action is required.
0x806f040c	806f040c-2001ffff 806f040c-2002ffff 806f040c-2003ffff 806f040c-2004ffff 806f040c-2005ffff 806f040c-2006ffff 806f040c-2007ffff 806f040c-2008ffff 806f040c-2009ffff 806f040c-200affff	Info	Memory device X (DIMM X) memory disabled [Note X = 1-12]	<ol style="list-style-type: none"> <li>1. If the memory module was disabled because of a memory fault (error code 0x806f010c, 0x806f030c, or 0x806f050c), follow the procedure for that event and restart the server.</li> <li>2. Check the IBM support website for an applicable retain tip or firmware update that applies to this memory event. If no memory fault is recorded</li> </ol>

- Follow the suggested actions in the order in which they are listed in the Action column until the problem is solved.
- See Chapter 3 “Parts listing” on page 33 to determine which components are consumable, structural, or CRU parts.
- If an action step is preceded by “(Trained technician only),” that step must be performed only by a trained technician.

Error Code	Event ID	Type	Error Message	Action
	806f040c-200bffff 806f040c-200cffff			in the logs and no DIMM connector error LED is lit, re-enable the memory modules using the Setup utility or the Advanced Settings Utility (ASU).
0x806f040c	806f040c-2581ffff	Info	Memory (All DIMMs) disabled.	<ol style="list-style-type: none"> <li>1. If the memory module was disabled due to a memory fault (error code 0x806f010c, 0x806f030c, or 0x806f050c), follow the procedure for that event and restart the server.</li> <li>2. Check the IBM support website for an applicable retain tip or firmware update that applies to this memory event. If no memory fault is recorded in the logs and no DIMM connector error LED is lit, re-enable the memory modules using the Setup utility or the Advanced Settings Utility (ASU).</li> </ol>
0x806f040c	806f040c-2581ffff	Info	Memory (One of the DIMMs) disabled.	<ol style="list-style-type: none"> <li>1. If the memory module was disabled due to a memory fault (error code 0x806f010c, 0x806f030c, or 0x806f050c), follow the procedure for that event and restart the server.</li> <li>2. Check the IBM support website for an applicable retain tip or firmware update that applies to this memory event. If no memory fault is recorded in the logs and no DIMM connector error LED is lit, re-enable the memory modules using the Setup utility or the Advanced Settings Utility (ASU).</li> </ol>
0x806f0507	806f0507-0301ffff 806f0507-0302ffff	Error	Processor (CPU X) has a Configuration Mismatch [Note: X=1,2]	<ol style="list-style-type: none"> <li>1. Remove the blade server and ensure the processors are installed correctly (see “Installing a microprocessor and heat sink” on page 73).</li> <li>2. Verify that the system is running the latest UEFI firmware (see “Updating firmware and device drivers” on page 23).</li> <li>3. Run the Setup utility (see “Using the Setup utility” on page 11). <ol style="list-style-type: none"> <li>a. Make sure that both processors are displayed by the system.</li> <li>b. Load the default settings.</li> <li>c. Go to the <b>System Settings</b> menu and make sure the processor is enabled.</li> </ol> </li> </ol>

- Follow the suggested actions in the order in which they are listed in the Action column until the problem is solved.
- See Chapter 3 “Parts listing” on page 33 to determine which components are consumable, structural, or CRU parts.
- If an action step is preceded by “(Trained technician only),” that step must be performed only by a trained technician.

Error Code	Event ID	Type	Error Message	Action
0x806f0507	806f0507-2584ffff	Error	Processor (All CPUs) has a Configuration Mismatch.	<ol style="list-style-type: none"> <li>1. Remove the blade server and ensure the processors are installed correctly (see “Installing a microprocessor and heat sink” on page 73).</li> <li>2. Verify that the system is running the latest UEFI firmware (see “Updating firmware and device drivers” on page 23).</li> <li>3. Run the Setup utility (see “Using the Setup utility” on page 11). <ol style="list-style-type: none"> <li>a. Make sure that both processors are displayed by the system.</li> <li>b. Load the default settings.</li> <li>c. Go to the <b>System Settings</b> menu and make sure the processor is enabled.</li> </ol> </li> </ol>
0x806f0507	806f0507-2584ffff	Error	Processor (One of CPUs) has a Configuration Mismatch.	<ol style="list-style-type: none"> <li>1. Remove the blade server and ensure the processors are installed correctly (see “Installing a microprocessor and heat sink” on page 73).</li> <li>2. Verify that the system is running the latest UEFI firmware (see “Updating firmware and device drivers” on page 23).</li> <li>3. Run the Setup utility (see “Using the Setup utility” on page 11). <ol style="list-style-type: none"> <li>a. Make sure that both processors are displayed by the system.</li> <li>b. Load the default settings.</li> <li>c. Go to the <b>System Settings</b> menu and make sure the processor is enabled.</li> </ol> </li> </ol>
0x806f050c	806f050c-2001ffff 806f050c-2002ffff 806f050c-2003ffff 806f050c-2004ffff 806f050c-2005ffff 806f050c-2006ffff 806f050c-2007ffff 806f050c-2008ffff 806f050c-2009ffff 806f050c-200affff 806f050c-200bffff 806f050c-200cffff	Error	Memory device X (DIMM X) correctable ECC memory error logging limit reached [Note X = 1-12]	<ol style="list-style-type: none"> <li>1. Refer to TIP H21455 for minimum code level.</li> <li>2. Check the IBM support website for an applicable retain tip or firmware update that applies to this memory error.</li> <li>3. Swap the affected memory modules (as indicated by the error LEDs on the system board or the event logs) to a different memory channel or microprocessor (see “Installing a memory module” on page 55 for memory population sequence).</li> </ol>

- Follow the suggested actions in the order in which they are listed in the Action column until the problem is solved.
- See Chapter 3 “Parts listing” on page 33 to determine which components are consumable, structural, or CRU parts.
- If an action step is preceded by “(Trained technician only),” that step must be performed only by a trained technician.

Error Code	Event ID	Type	Error Message	Action
				<ol style="list-style-type: none"> <li>4. If the error occurs again on the same memory module, replace the affected memory module.</li> <li>5. (Trained technician only) If the problem occurs on the same DIMM connector, check the DIMM connector. If the connector is damaged, replace the system-board assembly (see “Removing the system-board assembly” on page 78 and “Installing the system-board assembly” on page 79).</li> <li>6. (Trained technician only) Remove the affected microprocessor and check the microprocessor socket pins for any damaged pins. If a damage is found, replace the system-board assembly (see “Removing the system-board assembly” on page 78 and “Installing the system-board assembly” on page 79).</li> <li>7. (Trained technician only) Replace the affected microprocessor (See “Removing a microprocessor and heat sink” on page 70 and “Installing a microprocessor and heat sink” on page 73).</li> </ol>
0x806f050c	806f050c-2581ffff	Error	Memory (All DIMMs) correctable ECC memory error logging limit reached.	<ol style="list-style-type: none"> <li>1. Refer to TIP H21455 for minimum code level.</li> <li>2. Check the IBM support website for an applicable retain tip or firmware update that applies to this memory error.</li> <li>3. Swap the affected memory modules (as indicated by the error LEDs on the system board or the event logs) to a different memory channel or microprocessor (see “Installing a memory module” on page 55 for memory population sequence).</li> <li>4. If the error occurs again on the same memory module, replace the affected memory module.</li> <li>5. (Trained technician only) If the problem occurs on the same DIMM connector, check the DIMM connector. If the connector is damaged, replace the system-board assembly (see “Removing the system-board</li> </ol>



- Follow the suggested actions in the order in which they are listed in the Action column until the problem is solved.
- See Chapter 3 “Parts listing” on page 33 to determine which components are consumable, structural, or CRU parts.
- If an action step is preceded by “(Trained technician only),” that step must be performed only by a trained technician.

Error Code	Event ID	Type	Error Message	Action
				<p>assembly” on page 78 and “Installing the system-board assembly” on page 79).</p> <p>6. (Trained technician only) Remove the affected microprocessor and check the microprocessor socket pins for any damaged pins. If a damage is found, replace the system-board assembly (see “Removing the system-board assembly” on page 78 and “Installing the system-board assembly” on page 79).</p> <p>7. (Trained technician only) Replace the affected microprocessor (See “Removing a microprocessor and heat sink” on page 70 and “Installing a microprocessor and heat sink” on page 73).</p>
0x806f050c	806f050c-2581ffff	Error	Memory (One of DIMMs) correctable ECC memory error logging limit reached.	<ol style="list-style-type: none"> <li>1. Refer to TIP H21455 for minimum code level.</li> <li>2. Check the IBM support website for an applicable retain tip or firmware update that applies to this memory error.</li> <li>3. Swap the affected memory modules (as indicated by the error LEDs on the system board or the event logs) to a different memory channel or microprocessor (see “Installing a memory module” on page 55 for memory population sequence).</li> <li>4. If the error occurs again on the same memory module, replace the affected memory module.</li> <li>5. (Trained technician only) If the problem occurs on the same DIMM connector, check the DIMM connector. If the connector is damaged, replace the system-board assembly (see “Removing the system-board assembly” on page 78 and “Installing the system-board assembly” on page 79).</li> <li>6. (Trained technician only) Remove the affected microprocessor and check the microprocessor socket pins for any damaged pins. If a damage is found, replace the system-board assembly (see “Removing the system-board</li> </ol>

- Follow the suggested actions in the order in which they are listed in the Action column until the problem is solved.
- See Chapter 3 “Parts listing” on page 33 to determine which components are consumable, structural, or CRU parts.
- If an action step is preceded by “(Trained technician only),” that step must be performed only by a trained technician.

Error Code	Event ID	Type	Error Message	Action
				assembly” on page 78 and “Installing the system-board assembly” on page 79).  7. (Trained technician only) Replace the affected microprocessor (See “Removing a microprocessor and heat sink” on page 70 and “Installing a microprocessor and heat sink” on page 73).
0x806f050d	806f050d-0400ffff 806f050d-0401ffff	Error	Hard drive X (Drive X) in critical condition. [Note X=0,1]	1. Replace the storage drive (see “Removing a hot-swap storage drive” on page 53 and “Installing a hot-swap storage drive” on page 53).  2. After the storage drive has been replaced, rebuild the RAID array (see “Creating a RAID array of hard disk drives” on page 26).
0x806f052b	806f052b-2101ffff	Error	Invalid or Unsupported firmware or software was detected on system (IMM2 FW Failover).	Make sure you have the latest system firmware (see “Updating firmware and device drivers” on page 23).
0x806f0607	806f0607-0301ffff 806f0607-0302ffff	Error	Processor X (CPU X) SM BIOS uncorrectable CPU complex error [Note: X=1,2]	1. Verify that you have the latest system firmware (see “Updating firmware and device drivers” on page 23).  2. (Trained technician only) If the error still occurs, replace microprocessor X (see “Removing a microprocessor and heat sink” on page 70 and “Installing a microprocessor and heat sink” on page 73).  3. (Trained technician only) If the error continues, replace the system-board assembly (see “Removing the system-board assembly” on page 78 and “Installing the system-board assembly” on page 79).

- Follow the suggested actions in the order in which they are listed in the Action column until the problem is solved.
- See Chapter 3 “Parts listing” on page 33 to determine which components are consumable, structural, or CRU parts.
- If an action step is preceded by “(Trained technician only),” that step must be performed only by a trained technician.

Error Code	Event ID	Type	Error Message	Action
0x806f0607	806f0607-2584ffff	Error	Processor (All CPUs) SM BIOS uncorrectable CPU complex error.	<ol style="list-style-type: none"> <li>1. Verify that you have the latest system firmware (see “Updating firmware and device drivers” on page 23).</li> <li>2. Clear the CMOS data by removing the system battery for 30 seconds (see “Removing the battery” on page 51 and “Installing the battery” on page 51).</li> <li>3. (Trained technician only) If the error still occurs, replace the microprocessors one at a time (see “Removing a microprocessor and heat sink” on page 70 and “Installing a microprocessor and heat sink” on page 73).</li> <li>4. (Trained technician only) If the error continues, replace the system-board assembly (see “Removing the system-board assembly” on page 78 and “Installing the system-board assembly” on page 79).</li> </ol>
0x806f0607	806f0607-2584ffff	Error	Processor (One of CPUs) SM BIOS uncorrectable CPU complex error.	<ol style="list-style-type: none"> <li>1. Verify that you have the latest system firmware (see “Updating firmware and device drivers” on page 23).</li> <li>2. (Trained technician only) If the error still occurs, replace the microprocessors one at a time (see “Removing a microprocessor and heat sink” on page 70 and “Installing a microprocessor and heat sink” on page 73).</li> <li>3. (Trained technician only) If the error continues, replace the system-board assembly (see “Removing the system-board assembly” on page 78 and “Installing the system-board assembly” on page 79).</li> </ol>
0x806f060d	806f060d-0400ffff 806f060d-0401ffff	Error	Hard drive X (Drive X) in failed array [Note X=0,1]	<ol style="list-style-type: none"> <li>1. Replace the storage drive (see “Removing a hot-swap storage drive” on page 53 and “Installing a hot-swap storage drive” on page 53).</li> <li>2. After the storage drive has been replaced, rebuild the RAID array (see “Creating a RAID array of hard disk drives” on page 26).</li> </ol>

- Follow the suggested actions in the order in which they are listed in the Action column until the problem is solved.
- See Chapter 3 “Parts listing” on page 33 to determine which components are consumable, structural, or CRU parts.
- If an action step is preceded by “(Trained technician only),” that step must be performed only by a trained technician.

Error Code	Event ID	Type	Error Message	Action
0x806f070c	806f070c-2001ffff 806f070c-2002ffff 806f070c-2003ffff 806f070c-2004ffff 806f070c-2005ffff 806f070c-2006ffff 806f070c-2007ffff 806f070c-2008ffff 806f070c-2009ffff 806f070c-200affff 806f070c-200bffff 806f070c-200cffff	Error	Memory device X (DIMM X) memory configuration error [Note X=1-12]	Make sure that the memory modules are installed in the correct order and configured correctly (see “Installing a memory module” on page 55).
0x806f070c	806f070c-2581ffff	Error	Memory (All DIMMs) configuration error.	Make sure that the memory modules are installed in the correct order and configured correctly (see “Installing a memory module” on page 55).
0x806f070c	806f070c-2581ffff	Error	Memory (One of the DIMMs) configuration error.	Make sure that the memory modules are installed in the correct order and configured correctly (see “Installing a memory module” on page 55).
0x806f050d	806f070d-0400ffff 806f070d-0401ffff	Info	Hard drive X (Drive X) rebuilt in progress for Array in system. [Note X=0,1]	Information only; no action is required.
0x806f0807	806f0807-0301ffff 806f0807-0302ffff	Info	Processor X (CPU X) has been disabled. [Note X=1,2]	<ol style="list-style-type: none"> <li>1. Remove the blade server and ensure the processors are installed correctly (see “Installing a microprocessor and heat sink” on page 73).</li> <li>2. Check the event logs for other related error messages (see “Event logs” on page 85).</li> <li>3. Verify that the system is running the latest UEFI firmware (see “Updating firmware and device drivers” on page 23).</li> <li>4. Run the Setup utility (see “Using the Setup utility” on page 11). <ol style="list-style-type: none"> <li>a. Make sure that both processors are displayed by the system.</li> <li>b. Load the default settings.</li> <li>c. Go to the <b>System Settings</b> menu and make sure the processor is enabled.</li> </ol> </li> </ol>

- Follow the suggested actions in the order in which they are listed in the Action column until the problem is solved.
- See Chapter 3 “Parts listing” on page 33 to determine which components are consumable, structural, or CRU parts.
- If an action step is preceded by “(Trained technician only),” that step must be performed only by a trained technician.

Error Code	Event ID	Type	Error Message	Action
0x806f0807	806f0807-2584ffff	Info	Processor (All CPUs) has been disabled.	<ol style="list-style-type: none"> <li>1. Remove the blade server and ensure the processors are installed correctly (see “Installing a microprocessor and heat sink” on page 73).</li> <li>2. Check the event logs for other related error messages (see “Event logs” on page 85).</li> <li>3. Verify that the system is running the latest UEFI firmware (see “Updating firmware and device drivers” on page 23).</li> <li>4. Run the Setup utility (see “Using the Setup utility” on page 11). <ol style="list-style-type: none"> <li>a. Make sure that both processors are displayed by the system.</li> <li>b. Load the default settings.</li> <li>c. Go to the <b>System Settings</b> menu and make sure the processor is enabled.</li> </ol> </li> </ol>
0x806f0807	806f0807-2584ffff	Info	Processor (One of CPUs) has been disabled.	<ol style="list-style-type: none"> <li>1. Remove the blade server and ensure the processors are installed correctly (see “Installing a microprocessor and heat sink” on page 73).</li> <li>2. Check the event logs for other related error messages (see “Event logs” on page 85).</li> <li>3. Verify that the system is running the latest UEFI firmware (see “Updating firmware and device drivers” on page 23).</li> <li>4. Run the Setup utility (see “Using the Setup utility” on page 11). <ol style="list-style-type: none"> <li>a. Make sure that both processors are displayed by the system.</li> <li>b. Load the default settings.</li> <li>c. Go to the <b>System Settings</b> menu and make sure the processor is enabled.</li> </ol> </li> </ol>

- Follow the suggested actions in the order in which they are listed in the Action column until the problem is solved.
- See Chapter 3 “Parts listing” on page 33 to determine which components are consumable, structural, or CRU parts.
- If an action step is preceded by “(Trained technician only),” that step must be performed only by a trained technician.

Error Code	Event ID	Type	Error Message	Action
0x806f0813	806f0813-2581ffff	Error	Memory (DIMMs) uncorrectable error has occurred.	<ol style="list-style-type: none"> <li>1. Check the operating system event log and the system event log as it may contain additional information (see “Event logs” on page 85).</li> <li>2. Reseat the blade server in the BladeCenter (see “Removing the blade server from the BladeCenter unit” on page 41 and “Installing the blade server in a BladeCenter unit” on page 41).</li> <li>3. Update the device drivers for any expansion cards that are installed into the blade server.</li> <li>4. Reseat the expansion card (see “Removing an I/O expansion card” on page 60 and “Installing an I/O expansion card” on page 62).</li> <li>5. Replace the expansion card (see “Removing an I/O expansion card” on page 60 and “Installing an I/O expansion card” on page 62).</li> </ol>
0x806f0813	806f0813-2582ffff	Error	PCI (PCIs) uncorrectable error has occurred.	<ol style="list-style-type: none"> <li>1. Check the operating system event log and the system event log as it may contain additional information (see “Event logs” on page 85).</li> <li>2. Reseat the blade server in the BladeCenter (see “Removing the blade server from the BladeCenter unit” on page 41 and “Installing the blade server in a BladeCenter unit” on page 41).</li> <li>3. Update the device drivers for any expansion cards that are installed into the blade server.</li> <li>4. Reseat the expansion card (see “Removing an I/O expansion card” on page 60 and “Installing an I/O expansion card” on page 62).</li> <li>5. Replace the expansion card (see “Removing an I/O expansion card” on page 60 and “Installing an I/O expansion card” on page 62).</li> </ol>

- Follow the suggested actions in the order in which they are listed in the Action column until the problem is solved.
- See Chapter 3 “Parts listing” on page 33 to determine which components are consumable, structural, or CRU parts.
- If an action step is preceded by “(Trained technician only),” that step must be performed only by a trained technician.

Error Code	Event ID	Type	Error Message	Action
0x806f0813	806f0813-2584ffff	Error	Processor (CPUs) uncorrectable error has occurred.	<ol style="list-style-type: none"> <li>1. Remove the blade server and ensure the processors are installed correctly (see “Installing a microprocessor and heat sink” on page 73).</li> <li>2. Verify that the system is running the latest UEFI firmware (see “Updating firmware and device drivers” on page 23).</li> <li>3. Run the Setup utility (see “Using the Setup utility” on page 11). <ol style="list-style-type: none"> <li>a. Make sure that both processors are displayed by the system.</li> <li>b. Load the default settings.</li> <li>c. Go to the <b>System Settings</b> menu and make sure the processor is enabled.</li> </ol> </li> <li>4. (Trained technician only) If the problem continues, replace the processor (see “Removing a microprocessor and heat sink” on page 70 and “Installing a microprocessor and heat sink” on page 73).</li> <li>5. (Trained technician only) If the error continues, replace the system-board assembly (see “Removing the system-board assembly” on page 78 and “Installing the system-board assembly” on page 79).</li> </ol>
	806f0823-2101ffff	Info	Watchdog Timer interrupt occurred for sensor (IPMI Watchdog).	Information only; no action is required.
	806f090c-2001ffff 806f090c-2002ffff 806f090c-2003ffff 806f090c-2004ffff 806f090c-2005ffff 806f090c-2006ffff 806f090c-2007ffff 806f090c-2008ffff 806f090c-2009ffff 806f090c-200affff 806f090c-200bffff 806f090c-200cffff	Info	Memory device X, (DIMM X) memory Throttled X [Note X=1-12]	<ol style="list-style-type: none"> <li>1. Check the event logs for fan or cooling related issues (see “Event logs” on page 85).</li> <li>2. Make sure that the airflow at the front and rear of the chassis is not obstructed and the fillers are in place and correctly installed.</li> <li>3. Make sure that the room temperature is within the operating specifications.</li> <li>4. Make sure the air baffle and the fan fillers are installed correctly.</li> <li>5. If the problem remains and there is no other DIMM with the same issue, replace the affected DIMM (see</li> </ol>

- Follow the suggested actions in the order in which they are listed in the Action column until the problem is solved.
- See Chapter 3 “Parts listing” on page 33 to determine which components are consumable, structural, or CRU parts.
- If an action step is preceded by “(Trained technician only),” that step must be performed only by a trained technician.

Error Code	Event ID	Type	Error Message	Action
				“Removing a memory module” on page 54 and “Installing a memory module” on page 55).
	806f0a07-0301ffff 806f0a07-0302ffff	Warning	Processor X (CPU X) is operating in a Degraded State. [Note X=1,2]	<ol style="list-style-type: none"> <li>1. Check the event logs for fan, cooling, or power related issues (see “Event logs” on page 85).</li> <li>2. Make sure that the airflow at the front and rear of the chassis is not obstructed and the fillers are in place and correctly installed.</li> <li>3. Make sure that the room temperature is within the operating specifications.</li> <li>4. If the problem remains and there is no other DIMM with the same issue, replace the affected DIMM (see “Removing a memory module” on page 54 and “Installing a memory module” on page 55).</li> </ol>
0x806f0a0c	806f0a0c-2001ffff 806f0a0c-2002ffff 806f0a0c-2003ffff 806f0a0c-2004ffff 806f0a0c-2005ffff 806f0a0c-2006ffff 806f0a0c-2007ffff 806f0a0c-2008ffff 806f0a0c-2009ffff 806f0a0c-200affff 806f0a0c-200bffff 806f0a0c-200cffff	Error	Memory device X, (DIMM X) memory in critical over-temperature state Throttled X [Note X=1-12]	<ol style="list-style-type: none"> <li>1. Make sure that the room temperature is within the operating specifications (see “Features and specifications” on page 2).</li> <li>2. Make sure that none of the air vents on the BladeCenter unit and on the blade server are blocked.</li> <li>3. Make sure that all of the fans on the BladeCenter unit are running.</li> <li>4. Make sure the air baffle and the fan fillers are installed correctly.</li> </ol>

## Troubleshooting tables

Use this information to troubleshoot problems in the blade server.

Use the troubleshooting tables to find solutions to problems that have identifiable symptoms. If these symptoms are related to shared BladeCenter unit resources, see “Solving shared BladeCenter resource problems” on page 196.

If you cannot find a problem in these tables, see Chapter 5 “Diagnostics” on page 83 for information about testing the blade server.

If you have just added new software or a new optional device, and the blade server is not working, complete the following steps before you use the troubleshooting tables:

1. Remove the software or device that you just added.



2. Run the diagnostic tests to determine whether the blade server is running correctly. For more information, see “POST” on page 85.
3. Reinstall the new software or new device. For more information, see the documentation that came with the new software or device.

## General problems

Use this information to resolve a general hardware problem.

IBM updates the support website with the latest tips and techniques that you can use to resolve any problems. Go to the BladeCenter support search website at <http://www.ibm.com/supportportal/> to see if any service bulletins have been generated.

Follow the suggested actions in the order in which they are listed in the Action column until the problem is solved.

<ul style="list-style-type: none"> <li>• See Chapter 3 “Parts listing” on page 33 to determine which components are consumable, structural, or CRU parts.</li> <li>• If an action step is preceded by “(Trained technician only),” that step must be performed only by a trained technician.</li> </ul>	
Symptom	Action
A cover lock is broken, an LED is not working, or a similar problem has occurred.	If the part is a CRU, replace it - See “Removing and replacing Tier 1 customer replaceable units (CRUs)” on page 50 or “Removing and replacing Tier 2 CRUs ” on page 70 to replace the failed component. Some tier 2 CRU parts must be replaced by a trained technician.
The server is hung while the screen is on. Cannot start the Setup utility by pressing F1.	<ol style="list-style-type: none"> <li>1. See “Nx boot failure” on page 196 for more information.</li> <li>2. See “Recovering from a UEFI update failure” on page 192 for more information.</li> </ol>

## Hard disk drive problems

Use this information to resolve hard disk drive problems.

IBM updates the support website with the latest tips and techniques that you can use to resolve any problems. Go to the BladeCenter support search website at <http://www.ibm.com/supportportal/> to see if any service bulletins have been generated.

Follow the suggested actions in the order in which they are listed in the Action column until the problem is solved.

<ul style="list-style-type: none"> <li>• See Chapter 3 “Parts listing” on page 33 to determine which components are consumable, structural, or CRU parts.</li> <li>• If an action step is preceded by “(trained technician only),” that step must be performed only by a trained technician.</li> </ul>	
Symptom	Action
Not all storage drives are recognized by the Fixed Disk or	<ol style="list-style-type: none"> <li>1. Remove the storage drive that is indicated by the diagnostic tests. See Chapter 4 “Removing and replacing blade server components” on page 39.</li> <li>2. Run the SAS Fixed Disk or SAS Attached Disk diagnostic test again. See “Diagnostic tools overview” on page 84.</li> </ol>

<ul style="list-style-type: none"> <li>• See Chapter 3 “Parts listing” on page 33 to determine which components are consumable, structural, or CRU parts.</li> <li>• If an action step is preceded by “(trained technician only),” that step must be performed only by a trained technician.</li> </ul>	
Symptom	Action
SAS Attached Disk diagnostic test.	<ol style="list-style-type: none"> <li>3. If the Fixed Disk or SAS Attached Disk diagnostic test runs successfully, replace the storage drive that you removed with a new one. See Chapter 4 “Removing and replacing blade server components” on page 39.</li> </ol>
The blade server stops responding during the Fixed Disk or SAS Attached Disk diagnostic test.	<ol style="list-style-type: none"> <li>1. Remove the storage drive that was being tested when the blade server stopped responding. See Chapter 4 “Removing and replacing blade server components” on page 39.</li> <li>2. Run the SAS Fixed Disk or SAS Attached Disk diagnostic test again (see “Diagnostic tools overview” on page 84).</li> <li>3. If the Fixed Disk or SAS Attached Disk diagnostic test runs successfully, replace the storage drive that you removed with a new one. See Chapter 4 “Removing and replacing blade server components” on page 39.</li> </ol>
A storage drive passes the Fixed Disk or SAS Attached Disk diagnostics test, but the problem remains.	<ol style="list-style-type: none"> <li>1. Run the SAS Fixed Disk or SAS Attached Disk diagnostic test again. See “Diagnostic tools overview” on page 84.</li> <li>2. If the Fixed Disk or SAS Attached Disk diagnostic test runs successfully but the storage drive continues to have a problem, replace the drive with a new one.</li> </ol>

## Intermittent problems

Use this information to resolve intermittent problems with the blade server.

IBM updates the support website with the latest tips and techniques that you can use to resolve any problems. Go to the BladeCenter support search website at <http://www.ibm.com/supportportal/> to see if any service bulletins have been generated.

Follow the suggested actions in the order in which they are listed in the Action column until the problem is solved.

<ul style="list-style-type: none"> <li>• See Chapter 3 “Parts listing” on page 33 to determine which components are consumable, structural, or CRU parts.</li> <li>• If an action step is preceded by “(trained technician only),” that step must be performed only by a trained technician.</li> </ul>	
Symptom	Action
A problem occurs only occasionally and is difficult to diagnose.	<ol style="list-style-type: none"> <li>1. Make sure that: <ul style="list-style-type: none"> <li>• When the blade server is turned on, air is flowing from the rear of the BladeCenter unit at the blower grille. If there is no airflow, the blower is not working. This causes the blade server to overheat and shut down.</li> <li>• The SAS storage drives are configured correctly.</li> </ul> </li> <li>2. Check the AMM and IMM logs for an error message (see “Event logs” on page 85).</li> <li>3. See “Solving undetermined problems” on page 200.</li> </ol>

## Keyboard or mouse problems

Use this information to lookup and resolve keyboard or mouse problems.

IBM updates the support website with the latest tips and techniques that you can use to resolve any problems. Go to the BladeCenter support search website at <http://www.ibm.com/supportportal/> to see if any service bulletins have been generated.

Follow the suggested actions in the order in which they are listed in the Action column until the problem is solved. The keyboard and mouse are shared BladeCenter unit resources. First, make sure that the keyboard and mouse are assigned to the blade server; then, see the following table and “Solving shared BladeCenter resource problems” on page 196.

<ul style="list-style-type: none"> <li>• See Chapter 3 “Parts listing” on page 33 to determine which components are consumable, structural, or CRU parts.</li> <li>• If an action step is preceded by “(trained technician only),” that step must be performed only by a trained technician.</li> </ul>	
Symptom	Action
All keyboard and mouse problems.	<ol style="list-style-type: none"> <li>1. Make sure that the keyboard/video/mouse (KVM) select button LED on the front of the blade server is lit, indicating that the blade server is connected to the shared keyboard and mouse.</li> <li>2. Check the function of the shared BladeCenter unit resources (see “Solving shared BladeCenter resource problems” on page 196).</li> <li>3. Make sure that: <ul style="list-style-type: none"> <li>• The device drivers are installed correctly. See “Updating firmware and device drivers” on page 23</li> <li>• The keyboard and mouse are recognized as USB, not PS/2, devices by the blade server. Although the keyboard and mouse might be a PS/2-style devices, communication with them is through USB in the BladeCenter unit. Some operating systems allow you to select the type of keyboard and mouse during installation of the operating system. If this is the case, select USB.</li> </ul> </li> <li>4. (Trained technician only) Replace the system-board assembly (see “Removing the system-board assembly” on page 78 and “Installing the system-board assembly” on page 79).</li> </ol>

## Memory problems

Use this information to diagnose and resolve memory problems with the blade server.

IBM updates the support website with the latest tips and techniques that you can use to resolve any problems. Go to the BladeCenter support search website at <http://www.ibm.com/supportportal/> to see if any service bulletins have been generated.

Follow the suggested actions in the order in which they are listed in the Action column until the problem is solved.

<ul style="list-style-type: none"> <li>• See Chapter 3 “Parts listing” on page 33 to determine which components are consumable, structural, or CRU parts.</li> <li>• If an action step is preceded by “(trained technician only),” that step must be performed only by a trained technician.</li> </ul>	
Symptom	Action
The amount of system memory that is displayed is less than the amount of installed physical memory.	<ol style="list-style-type: none"> <li>1. Make sure that: <ul style="list-style-type: none"> <li>• You have installed the correct type of memory (see “Installing a memory module” on page 55).</li> <li>• If you changed the memory, you updated the memory configuration in the Setup utility (see “Using the Setup utility” on page 11).</li> </ul> </li> </ol>

<ul style="list-style-type: none"> <li>• See Chapter 3 “Parts listing” on page 33 to determine which components are consumable, structural, or CRU parts.</li> <li>• If an action step is preceded by “(trained technician only),” that step must be performed only by a trained technician.</li> </ul>	
Symptom	Action
	<ul style="list-style-type: none"> <li>• All banks of memory are enabled. The blade server might have automatically disabled a memory bank when it detected a problem, or a memory bank might have been manually disabled (see “Using the Setup utility” on page 11).</li> </ul> <ol style="list-style-type: none"> <li>2. Check the event log for a memory error (see “Event logs” on page 85), follow the actions to correct them.</li> <li>3. Run the Setup utility to re-enable all disabled DIMMs (see “Using the Setup utility” on page 11).</li> <li>4. Save the settings and exit the Setup utility.</li> </ol>
Multiple rows of DIMMs in a branch are identified as failing.	<ol style="list-style-type: none"> <li>1. Make sure that the DIMMs are installed in the proper sequence (see “Installing a memory module” on page 55).</li> <li>2. Reseat the DIMMs and restart the server (see “Removing a memory module” on page 54 and “Installing a memory module” on page 55).</li> <li>3. Remove each DIMM one at a time, restarting the server after removing each DIMM until the error is gone (see “Removing a memory module” on page 54).</li> <li>4. Replace the failed DIMM; then, reinstall the DIMMs to their original connectors and restart the server (see “Installing a memory module” on page 55).</li> <li>5. (Trained technician only) Replace the system board (see “Removing the system-board assembly” on page 78 and “Installing the system-board assembly” on page 79).</li> </ol>

## Monitor or video problems

Use this information to diagnose and resolve monitor or video errors.

IBM updates the support website with the latest tips and techniques that you can use to resolve any problems. Go to the BladeCenter support search website at <http://www.ibm.com/supportportal/> to see if any service bulletins have been generated.

Follow the suggested actions in the order in which they are listed in the Action column until the problem is solved.

The video monitor is a shared BladeCenter unit resource. First, make sure that the video monitor is assigned to the blade server; then, see the following table and “Solving shared BladeCenter resource problems” on page 196.

<ul style="list-style-type: none"> <li>• See Chapter 3 “Parts listing” on page 33 to determine which components are consumable, structural, or CRU parts.</li> <li>• If an action step is preceded by “(trained technician only),” that step must be performed only by a trained technician.</li> </ul>	
Symptom	Action
The screen is blank.	<ol style="list-style-type: none"> <li>1. Check the function of the shared BladeCenter unit resources (see “Solving shared BladeCenter resource problems” on page 196).</li> <li>2. Make sure that the blade server is turned on (see “Turning on the blade server” on page 6).</li> <li>3. Make sure that the monitor is connected properly. See the documentation for your BladeCenter unit for more information.</li> <li>4. Make sure that:</li> </ol>

<ul style="list-style-type: none"> <li>• See Chapter 3 “Parts listing” on page 33 to determine which components are consumable, structural, or CRU parts.</li> <li>• If an action step is preceded by “(trained technician only),” that step must be performed only by a trained technician.</li> </ul>	
Symptom	Action
	<ul style="list-style-type: none"> <li>• Damaged BIOS code is not affecting the video; see “Recovering from a UEFI update failure” on page 192.</li> <li>• The device drivers are installed correctly.</li> </ul> <p>5. (Trained technician only) Replace the system-board assembly (see “Removing the system-board assembly” on page 78 and “Installing the system-board assembly” on page 79).</p>
The monitor has screen jitter, or the screen image is wavy, unreadable, rolling, or distorted.	<ol style="list-style-type: none"> <li>1. Check the function of the shared BladeCenter unit resources (see “Solving shared BladeCenter resource problems” on page 196).</li> <li>2. (Trained technician only) Replace the system-board assembly (see “Removing the system-board assembly” on page 78 and “Installing the system-board assembly” on page 79).</li> </ol>
Wrong characters appear on the screen.	<ol style="list-style-type: none"> <li>1. If the wrong language is displayed, update the firmware or operating system with the correct language in the blade server that has ownership of the monitor.</li> <li>2. Check the function of the shared BladeCenter unit resources (see “Solving shared BladeCenter resource problems” on page 196).</li> <li>3. (Trained technician only) Replace the system-board assembly (see “Removing the system-board assembly” on page 78 and “Installing the system-board assembly” on page 79).</li> </ol>

## Network connection problems

Use this information to diagnose and resolve network connection errors.

IBM updates the support website with the latest tips and techniques that you can use to resolve any problems. Go to the BladeCenter support search website at <http://www.ibm.com/supportportal/> to see if any service bulletins have been generated.

Follow the suggested actions in the order in which they are listed in the Action column until the problem is solved. The blade server connects to the network by using shared BladeCenter unit resources. See the following table and “Solving shared BladeCenter resource problems” on page 196.

<ul style="list-style-type: none"> <li>• See Chapter 3 “Parts listing” on page 33 to determine which components are consumable, structural, or CRU parts.</li> <li>• If an action step is preceded by “(trained technician only),” that step must be performed only by a trained technician.</li> </ul>	
Symptom	Action
One or more blade servers are unable to communicate with the network.	<ol style="list-style-type: none"> <li>1. Check the function of the shared BladeCenter unit resources. See “Solving shared BladeCenter resource problems” on page 196).</li> <li>2. Make sure that: <ul style="list-style-type: none"> <li>• The correct device drivers are installed. See “Updating firmware and device drivers” on page 23.</li> <li>• The Ethernet controller is correctly configured. See “Configuring the Gigabit Ethernet controller” on page 25.</li> <li>• Optional I/O expansion cards are correctly installed and configured. See “Installing an I/O expansion card” on page 62 and Chapter 2 “Configuring the blade server” on page 11.</li> </ul> </li> </ol>

<ul style="list-style-type: none"> <li>• See Chapter 3 “Parts listing” on page 33 to determine which components are consumable, structural, or CRU parts.</li> <li>• If an action step is preceded by “(trained technician only),” that step must be performed only by a trained technician.</li> </ul>	
Symptom	Action
	3. (Trained technician only) Replace the system-board assembly. See “Removing the system-board assembly” on page 78 and “Installing the system-board assembly” on page 79.

## Optional-device problems

Use this information to diagnose and resolve optional-device problems.

IBM updates the support website with the latest tips and techniques that you can use to resolve any problems. Go to the BladeCenter support search website at <http://www.ibm.com/supportportal/> to see if any service bulletins have been generated.

Follow the suggested actions in the order in which they are listed in the Action column until the problem is solved.

<ul style="list-style-type: none"> <li>• See Chapter 3 “Parts listing” on page 33 to determine which components are consumable, structural, or CRU parts.</li> <li>• If an action step is preceded by “(trained technician only),” that step must be performed only by a trained technician.</li> </ul>	
Symptom	Action
An IBM optional device that was just installed does not work.	<ol style="list-style-type: none"> <li>1. Make sure that: <ul style="list-style-type: none"> <li>• The device is designed for the blade server. See <a href="http://www.ibm.com/systems/info/x86servers/serverproven/compat/us/">http://www.ibm.com/systems/info/x86servers/serverproven/compat/us/</a>.</li> <li>• You followed the installation instructions that came with the device and the device is installed correctly. See the instructions that came with the device.</li> <li>• You have not loosened any other installed devices or cables.</li> <li>• You updated the configuration information in the Setup utility program. Whenever memory or any other device is changed, you must update the configuration. See “Setup utility menu” on page 12.</li> </ul> </li> <li>2. If the device comes with its own test instructions, use those instructions to test the device.</li> <li>3. Reseat the device that you just installed. See Chapter 4 “Removing and replacing blade server components” on page 39.</li> <li>4. Replace the device that you just installed. See Chapter 4 “Removing and replacing blade server components” on page 39.</li> </ol>

## Power error messages

Use this information to diagnose and resolve power error messages for the blade server.

IBM updates the support website with the latest tips and techniques that you can use to resolve any problems. Go to the BladeCenter support search website at <http://www.ibm.com/supportportal/> to see if any service bulletins have been generated.

Follow the suggested actions in the order in which they are listed in the Action column until the problem is solved. Power to the blade server is provided by shared BladeCenter unit resources. See the following table and “Solving shared BladeCenter resource problems” on page 196.

- See Chapter 3 “Parts listing” on page 33 to determine which components are consumable, structural, or CRU parts.
- If an action step is preceded by “(trained technician only),” that step must be performed only by a trained technician.

Message	Action
System Power Good fault	<ol style="list-style-type: none"> <li>1. Reseat the blade server - See “Removing the blade server from the BladeCenter unit” on page 41 and “Installing the blade server in a BladeCenter unit” on page 41.</li> <li>2. Check the function of the shared BladeCenter unit resources. See “Solving shared BladeCenter resource problems” on page 196.</li> <li>3. If an optional expansion unit is installed, reseat it. See “Removing an optional expansion unit” on page 68 and “Installing an optional expansion unit” on page 69.</li> <li>4. Replace the following components one at a time, in the order shown, restarting the blade server each time:               <ol style="list-style-type: none"> <li>a. Optional expansion unit (if one is installed). See “Removing an optional expansion unit” on page 68 and “Installing an optional expansion unit” on page 69.</li> <li>b. (Trained technician only) System-board assembly. See “Removing the system-board assembly” on page 78 and “Installing the system-board assembly” on page 79.</li> </ol> </li> </ol>
VRD Power Good fault	<ol style="list-style-type: none"> <li>1. Reseat the blade server - See “Removing the blade server from the BladeCenter unit” on page 41 and “Installing the blade server in a BladeCenter unit” on page 41.</li> <li>2. Check the function of the shared BladeCenter unit resources. See “Solving shared BladeCenter resource problems” on page 196.</li> <li>3. (Trained technician only) Replace the system-board assembly. See “Removing the system-board assembly” on page 78 and “Installing the system-board assembly” on page 79.</li> </ol>
System over recommended voltage for +12 V.	<p>Informational only.</p> <p><b>Note:</b> If the problem remains, complete the following steps:</p> <ol style="list-style-type: none"> <li>1. Reseat the blade server - See “Removing the blade server from the BladeCenter unit” on page 41 and “Installing the blade server in a BladeCenter unit” on page 41.</li> <li>2. Check the function of the shared BladeCenter unit resources. See “Solving shared BladeCenter resource problems” on page 196.</li> <li>3. (Trained technician only) Replace the system-board assembly. See “Removing the system-board assembly” on page 78 and “Installing the system-board assembly” on page 79.</li> </ol>
System over recommended voltage for +0.9 V.	<p>Informational only.</p> <p><b>Note:</b> If the problem remains, complete the following steps:</p> <ol style="list-style-type: none"> <li>1. Reseat the blade server - See “Removing the blade server from the BladeCenter unit” on page 41 and “Installing the blade server in a BladeCenter unit” on page 41.</li> <li>2. Check the function of the shared BladeCenter unit resources. See “Solving shared BladeCenter resource problems” on page 196.</li> <li>3. (Trained technician only) Replace the system-board assembly. See “Removing the system-board assembly” on page 78 and “Installing the system-board assembly” on page 79.</li> </ol>

- See Chapter 3 “Parts listing” on page 33 to determine which components are consumable, structural, or CRU parts.
- If an action step is preceded by “(trained technician only),” that step must be performed only by a trained technician.

Message	Action
System over recommended voltage for +3.3 V.	<p>Informational only.</p> <p><b>Note:</b> If the problem remains, complete the following steps:</p> <ol style="list-style-type: none"> <li>1. Reseat the blade server. See “Removing the blade server from the BladeCenter unit” on page 41 and “Installing the blade server in a BladeCenter unit” on page 41.</li> <li>2. Check the function of the shared BladeCenter unit resources. See “Solving shared BladeCenter resource problems” on page 196.</li> <li>3. (Trained technician only) Replace the system-board assembly. See “Removing the system-board assembly” on page 78 and “Installing the system-board assembly” on page 79.</li> </ol>
System over recommended 5 V fault.	<p>Informational only.</p> <p><b>Note:</b> If the problem remains, complete the following steps:</p> <ol style="list-style-type: none"> <li>1. Reseat the blade server. See “Removing the blade server from the BladeCenter unit” on page 41 and “Installing the blade server in a BladeCenter unit” on page 41.</li> <li>2. Check the function of the shared BladeCenter unit resources. See “Solving shared BladeCenter resource problems” on page 196.</li> <li>3. (Trained technician only) Replace the system-board assembly. See “Removing the system-board assembly” on page 78 and “Installing the system-board assembly” on page 79.</li> </ol>
System under recommended voltage for +12 V.	<p>Informational only.</p> <p><b>Note:</b> If the problem remains, complete the following steps:</p> <ol style="list-style-type: none"> <li>1. Reseat the blade server. See “Removing the blade server from the BladeCenter unit” on page 41 and “Installing the blade server in a BladeCenter unit” on page 41.</li> <li>2. Check the function of the shared BladeCenter unit resources. See “Solving shared BladeCenter resource problems” on page 196.</li> <li>3. (Trained technician only) Replace the system-board assembly. See “Removing the system-board assembly” on page 78 and “Installing the system-board assembly” on page 79.</li> </ol>
System under recommended voltage for +0.9 V.	<p>Informational only.</p> <p><b>Note:</b> If the problem remains, complete the following steps:</p> <ol style="list-style-type: none"> <li>1. Reseat the blade server. See “Removing the blade server from the BladeCenter unit” on page 41 and “Installing the blade server in a BladeCenter unit” on page 41.</li> <li>2. Check the function of the shared BladeCenter unit resources. See “Solving shared BladeCenter resource problems” on page 196.</li> <li>3. (Trained technician only) Replace the system-board assembly. See “Removing the system-board assembly” on page 78 and “Installing the system-board assembly” on page 79.</li> </ol>



<ul style="list-style-type: none"> <li>• See Chapter 3 “Parts listing” on page 33 to determine which components are consumable, structural, or CRU parts.</li> <li>• If an action step is preceded by “(trained technician only),” that step must be performed only by a trained technician.</li> </ul>	
Message	Action
System under recommended voltage for +3.3 V.	<p>Informational only.</p> <p><b>Note:</b> If the problem remains, complete the following steps:</p> <ol style="list-style-type: none"> <li>1. Reseat the blade server. See “Removing the blade server from the BladeCenter unit” on page 41 and “Installing the blade server in a BladeCenter unit” on page 41.</li> <li>2. Check the function of the shared BladeCenter unit resources. See “Solving shared BladeCenter resource problems” on page 196.</li> <li>3. (Trained technician only) Replace the system-board assembly. See “Removing the system-board assembly” on page 78 and “Installing the system-board assembly” on page 79.</li> </ol>
System under recommended +5 V fault.	<p>Informational only.</p> <p><b>Note:</b> If the problem remains, complete the following steps:</p> <ol style="list-style-type: none"> <li>1. Reseat the blade server. See “Removing the blade server from the BladeCenter unit” on page 41 and “Installing the blade server in a BladeCenter unit” on page 41.</li> <li>2. Check the function of the shared BladeCenter unit resources. See “Solving shared BladeCenter resource problems” on page 196.</li> <li>3. (Trained technician only) Replace the system-board assembly. See “Removing the system-board assembly” on page 78 and “Installing the system-board assembly” on page 79.</li> </ol>

## Power problems

Use this information to diagnose and resolve power problems for the blade server.

IBM updates the support website with the latest tips and techniques that you can use to resolve any problems. Go to the BladeCenter support search website at <http://www.ibm.com/supportportal/> to see if any service bulletins have been generated.

Follow the suggested actions in the order in which they are listed in the Action column until the problem is solved.

<ul style="list-style-type: none"> <li>• See Chapter 3 “Parts listing” on page 33 to determine which components are consumable, structural, or CRU parts.</li> <li>• If an action step is preceded by “(trained technician only),” that step must be performed only by a trained technician.</li> </ul>	
Symptom	Action
The power button does not work.	<ol style="list-style-type: none"> <li>1. Reseat the control-panel connector. See “Blade server controls and LEDs” on page 3.</li> <li>2. Replace the bezel assembly. See “Removing the bezel assembly” on page 45 and “Installing the bezel assembly” on page 46.</li> </ol>

- See Chapter 3 “Parts listing” on page 33 to determine which components are consumable, structural, or CRU parts.
- If an action step is preceded by “(trained technician only),” that step must be performed only by a trained technician.

Symptom	Action
	3. (Trained technician only) Replace the system-board assembly. See “Removing the system-board assembly” on page 78 and “Installing the system-board assembly” on page 79.
The blade server does not turn on.	<ol style="list-style-type: none"> <li>1. Check the function of the shared BladeCenter unit resources. See “Solving shared BladeCenter resource problems” on page 196.</li> <li>2. Make sure that the power LED on the blade server control panel is flashing slowly. See “Blade server controls and LEDs” on page 3.             <ul style="list-style-type: none"> <li>• If the power LED is flashing rapidly and continues to do so, the blade server is not communicating with the Advanced Management Module; reseal the blade server. See “Removing the blade server from the BladeCenter unit” on page 41 and “Installing the blade server in a BladeCenter unit” on page 41.</li> <li>• If the power LED is off, the blade server bay is not receiving power, the blade server is defective, or the LED information panel is loose or defective. See “Removing the blade server from the BladeCenter unit” on page 41 and “Installing the blade server in a BladeCenter unit” on page 41.</li> </ul> </li> <li>3. Check the power-management policies in the operating system for the blade server. See the <i>Advanced Management Module User's Guide</i> for more information.</li> <li>4. Check the Advanced-Management-Module log of the corresponding blade server for an error that is preventing the blade server from turning on. See “Event logs” on page 85.</li> <li>5. Reseat the blade server. See “Removing the blade server from the BladeCenter unit” on page 41 and “Installing the blade server in a BladeCenter unit” on page 41.</li> <li>6. If you just installed a device in the blade server, remove it and restart the blade server. If the blade server now starts, you might have installed more devices than the power to that blade server bay supports.</li> <li>7. If you tried another blade server in the blade server bay when you check the function of the shared BladeCenter unit resources and the other blade server worked, complete the following tasks on the blade server that you removed:             <ol style="list-style-type: none"> <li>a. If an optional expansion unit is installed, reseal it. See “Removing an optional expansion unit” on page 68 and “Installing an optional expansion unit” on page 69.</li> <li>b. Replace the following components one at a time, in the order shown, restarting the blade server each time:                 <ol style="list-style-type: none"> <li>1) Optional expansion unit (if one is installed). See “Removing an optional expansion unit” on page 68 and “Installing an optional expansion unit” on page 69.</li> <li>2) (Trained technician only) System-board assembly. See “Removing the system-board assembly” on page 78 and “Installing the system-board assembly” on page 79.</li> </ol> </li> </ol> </li> <li>8. See “Solving undetermined problems” on page 200.</li> </ol>

<ul style="list-style-type: none"> <li>• See Chapter 3 “Parts listing” on page 33 to determine which components are consumable, structural, or CRU parts.</li> <li>• If an action step is preceded by “(trained technician only),” that step must be performed only by a trained technician.</li> </ul>	
Symptom	Action
The blade server turns off for no apparent reason.	<ol style="list-style-type: none"> <li>1. Check the function of the shared BladeCenter unit resources. See “Solving shared BladeCenter resource problems” on page 196.</li> <li>2. (Trained technician only) If the microprocessor error LED is lit, replace the microprocessor. See “Removing a microprocessor and heat sink” on page 70 and “Installing a microprocessor and heat sink” on page 73.</li> <li>3. (Trained technician only) Replace the system-board assembly. See “Removing the system-board assembly” on page 78 and “Installing the system-board assembly” on page 79.</li> </ol>
The blade server does not turn off.	<ol style="list-style-type: none"> <li>1. Verify whether you are using an Advanced Configuration and Power Interface (ACPI) or non-ACPI operating system.</li> <li>2. If you are using a non-ACPI operating system, complete the following steps: <ol style="list-style-type: none"> <li>a. Turn off the blade server by pressing the power button for 4 seconds. See “Blade server controls and LEDs” on page 3.</li> <li>b. If the blade server fails during POST and the power button does not work, remove the blade server from the bay and reseal it. See “Removing the blade server from the BladeCenter unit” on page 41 and “Installing the blade server in a BladeCenter unit” on page 41.</li> </ol> </li> <li>3. If the problem remains or if you are using an ACPI-aware operating system, complete the following steps: <ol style="list-style-type: none"> <li>a. Check the power-management policies in the operating system for the blade server.</li> <li>b. (Trained technician only) Replace the system-board assembly. See “Removing the system-board assembly” on page 78 and “Installing the system-board assembly” on page 79.</li> </ol> </li> </ol>

## Removable-media drive problems

Use this information to diagnose and resolve removable-media drive problems in the blade server.

IBM updates the support website with the latest tips and techniques that you can use to resolve any problems. Go to the BladeCenter support search website at <http://www.ibm.com/supportportal/> to see if any service bulletins have been generated.

Follow the suggested actions in the order in which they are listed in the Action column until the problem is solved. The removable-media (CD, DVD, or diskette) drives are shared BladeCenter unit resources. First, make sure that the drives are assigned to the blade server; then, see the following table and “Solving shared BladeCenter resource problems” on page 196.

<ul style="list-style-type: none"> <li>• See Chapter 3 “Parts listing” on page 33 to determine which components are consumable, structural, or CRU parts.</li> <li>• If an action step is preceded by “(trained technician only),” that step must be performed only by a trained technician.</li> </ul>	
Symptom	Action
All removable-media drive problems.	<ol style="list-style-type: none"> <li>1. The media-tray select button LED on the front of the blade server is lit, indicating that the blade server is connected to the shared removable-media drives.</li> <li>2. Check the function of the shared BladeCenter unit resources. See “Solving shared BladeCenter resource problems” on page 196.</li> <li>3. Run the Setup utility and make sure that the drive is enabled. See “Setup utility menu” on page 12.</li> <li>4. For SAS storage drive problems, make sure that the correct device driver is installed. For the latest device drivers, go to <a href="http://www.ibm.com/supportportal/">http://www.ibm.com/supportportal/</a>.</li> <li>5. Reseat the battery - See “Removing the battery” on page 51 and “Installing the battery” on page 51.</li> <li>6. Replace the battery - See “Removing the battery” on page 51 and “Installing the battery” on page 51.</li> <li>7. (Trained technician only) Replace the system-board assembly - See “Removing the system-board assembly” on page 78 and “Installing the system-board assembly” on page 79.</li> </ol>
The CD or DVD drive is detected as /dev/sr0 by SUSE Linux. (If the SUSE Linux operating system is installed remotely on a blade server that is not the current owner of the media tray [CD or DVD drive, diskette drive, and USB port], SUSE Linux detects the CD or DVD drive as /dev/sr0 instead of /dev/cdrom.)	<p>Establish a link between /dev/sr0 and /dev/cdrom as follows:</p> <ol style="list-style-type: none"> <li>1. Enter the following command:  <pre>rm /dev/cdrom; ln -s /dev/sr0 /dev/cdrom</pre> </li> <li>2. Insert the following line in the /etc/fstab file:  <pre>/dev/cdrom /media/cdrom auto ro,noauto,user,exec 0 0</pre> </li> </ol>

## ServerGuide problems

Use this information to locate ServerGuide problems and suggested actions.

The following table lists problem symptoms and suggested solutions.

Symptom	Suggested action
The <i>ServerGuide Setup and Installation</i> CD will not start.	<ul style="list-style-type: none"> <li>• Make sure that the CD drive is associated with the blade server that you are configuring.</li> <li>• Make sure that the blade server supports the ServerGuide program and has a bootable CD (or DVD) drive.</li> <li>• If the startup (boot) sequence settings have been changed, make sure that the CD drive is first in the startup sequence.</li> </ul>
The RAID configuration program cannot view all installed drives, or the operating system cannot be installed.	<ul style="list-style-type: none"> <li>• Make sure that there are no duplicate SCSI/SAS IDs or interrupt request (IRQ) assignments. See “Creating a RAID array of hard disk drives” on page 26.</li> <li>• Make sure that the storage drive is connected correctly. See “Blade server connectors” on page 7 to locate the storage drive connector.</li> </ul>
The operating-system installation program continuously loops.	Make more space available on the hard disk.

Symptom	Suggested action
The ServerGuide program will not start the operating-system CD.	Make sure that the operating-system CD is supported by the ServerGuide program. See the <i>ServerGuide Setup and Installation</i> CD label for a list of supported operating-system versions.
The operating system cannot be installed; the option is not available.	Make sure that the operating system is supported on the blade server. If the operating system is supported, either no logical drive is defined (SCSI/SAS RAID systems) or the ServerGuide System Partition is not present. Run the ServerGuide program and make sure that setup is complete.

## Service processor problems

Use this information to diagnose and resolve service processor problems for the blade server.

IBM updates the support website with the latest tips and techniques that you can use to resolve any problems. Go to the BladeCenter support search website at <http://www.ibm.com/supportportal/> to see if any service bulletins have been generated.

Follow the suggested actions in the order in which they are listed in the Action column until the problem is solved.

<ul style="list-style-type: none"> <li>• See Chapter 3 “Parts listing” on page 33 to determine which components are consumable, structural, or CRU parts.</li> <li>• If an action step is preceded by “(trained technician only),” that step must be performed only by a trained technician.</li> </ul>	
Symptom	Action
The management module reports a general monitor failure.	Disconnect the BladeCenter unit from all electrical sources, wait for 30 seconds, reconnect the BladeCenter unit to the electrical sources, and restart the blade server. If the problem remains, see “Solving undetermined problems” on page 200.

## Software problems

Use this information to diagnose and resolve software problems for the blade server.

Follow the suggested actions in the order in which they are listed in the Action column until the problem is solved.

<ul style="list-style-type: none"> <li>• See Chapter 3 “Parts listing” on page 33 to determine which components are consumable, structural, or CRU parts.</li> <li>• If an action step is preceded by “(trained technician only),” that step must be performed only by a trained technician.</li> </ul>	
Symptom	Action
You suspect a software problem.	<ol style="list-style-type: none"> <li>1. To determine whether the problem is caused by the software, make sure that: <ul style="list-style-type: none"> <li>• The blade server has the minimum memory that is needed to use the software. For memory requirements, see the information that comes with the software.</li> </ul> <p><b>Note:</b> If you have just installed an adapter or memory, the blade server might have a memory-address conflict.</p> <ul style="list-style-type: none"> <li>• The software is designed to operate on the blade server.</li> <li>• Other software works on the blade server.</li> <li>• The software works on another server.</li> </ul> </li> <li>2. If you receive any error messages while you use the software, see the information that comes with the software for a description of the messages and suggested solutions to the problem.</li> <li>3. Contact your place of purchase of the software.</li> </ol>

## Universal Serial Bus (USB) port problems

Use this information to diagnose and resolve USB port problems in the blade server.

IBM updates the support website with the latest tips and techniques that you can use to resolve any problems. Go to the BladeCenter support search website at <http://www.ibm.com/supportportal/> to see if any service bulletins have been generated.

The USB ports are shared BladeCenter unit resources. First, make sure that the USB ports are assigned to the blade server; then, see the following table and “Solving shared BladeCenter resource problems” on page 196.

Follow the suggested actions in the order in which they are listed in the Action column until the problem is solved.

<ul style="list-style-type: none"><li>• See Chapter 3 “Parts listing” on page 33 to determine which components are consumable, structural, or CRU parts.</li><li>• If an action step is preceded by “(trained technician only),” that step must be performed only by a trained technician.</li></ul>	
Symptom	Action
A USB device does not work.	<ol style="list-style-type: none"><li>1. Check the function of the shared BladeCenter unit resources. See “Solving shared BladeCenter resource problems” on page 196.</li><li>2. Make sure that:<ul style="list-style-type: none"><li>• The operating system supports USB devices.</li><li>• The correct USB device driver is installed. For the latest device drivers, go to <a href="http://www.ibm.com/supportportal/">http://www.ibm.com/supportportal/</a>.</li></ul></li><li>3. (Trained technician only) Replace the system-board assembly. See “Removing the system-board assembly” on page 78 and “Installing the system-board assembly” on page 79.</li></ol>

---

## Light path diagnostics

Use this information as an overview of light path diagnostics.

Light path diagnostics is a system of LEDs on the control panel and on various internal components of the blade server or expansion unit. When an error occurs, LEDs can be lit throughout the blade server or expansion unit to help identify the source of the error.

After you remove the blade server or expansion unit, you can press and hold the power button for a maximum of 25 seconds to light the LEDs and locate the failing component.

## Viewing the light path diagnostics LEDs in the blade server

Use this information to locate and identify the light path diagnostics LEDs.

Before you work inside the blade server to view light path diagnostics LEDs, read “Safety” on page v and “Installation guidelines” on page 39.

If an error occurs, view the light path diagnostics LEDs in the following order:

- Step 1. Look at the control panel on the front of the blade server (see “Blade server controls and LEDs” on page 3).
  - If the information LED is lit, it indicates that information about a suboptimal condition in the blade server is available in the IMM log or in the Advanced-Management-Module event log.

- If the blade-error LED is lit, it indicates that an error has occurred; view the light path diagnostics panel (located under the blade server) and LEDs on the system board to isolate the failing component.

Step 2. To view the light path diagnostics panel and LEDs, complete the following steps:

- Remove the blade server from the BladeCenter unit. See “Removing the blade server from the BladeCenter unit” on page 41.
- Place the blade server on a flat, static-protective surface.
- Remove the cover from the blade server. See “Removing the blade server cover” on page 43.
- Press and hold the power button to light the LEDs of the failing components in the blade server. The LEDs will remain lit for as long as you press the switch, to a maximum of 25 seconds.

The following illustration shows the LEDs on the system board.

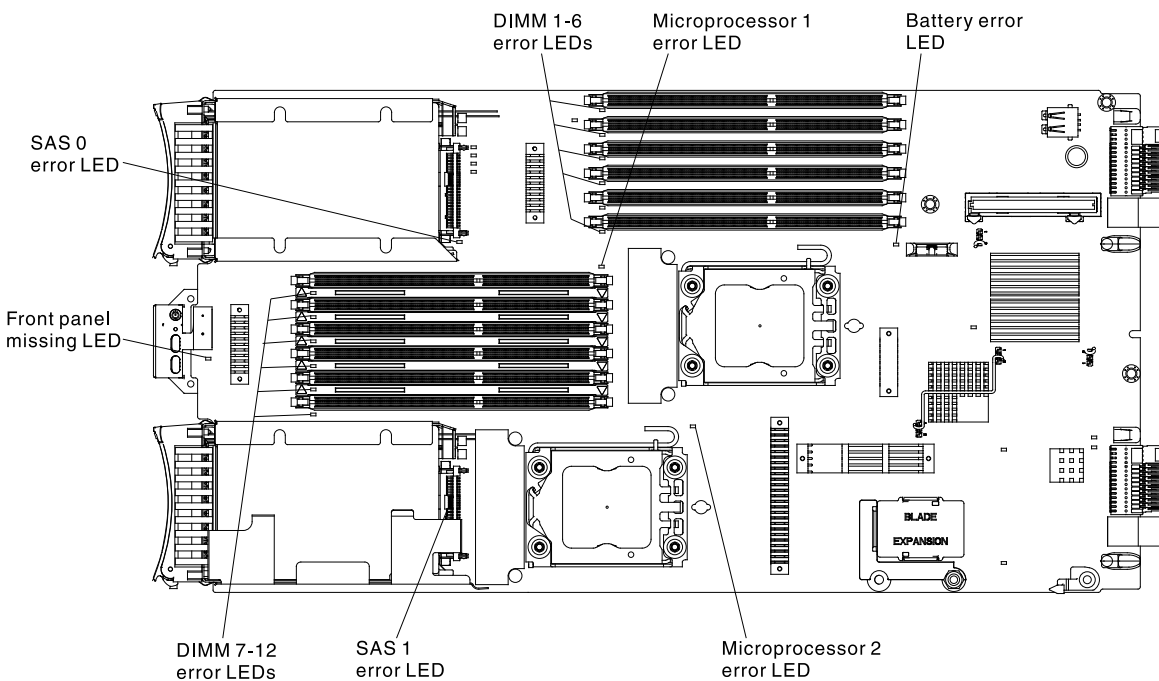

The following illustration shows the light path diagnostics panel on the system board.

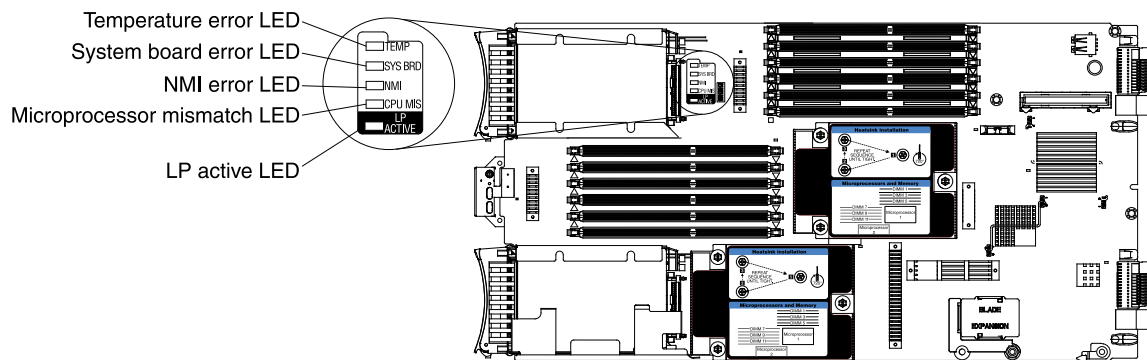

## Blade server light path diagnostics LEDs

Use this information to diagnose and resolve possible errors displayed by the light path diagnostic LEDs.

The following table describes the LEDs on the light path diagnostics panels, on the system board, and on the optional expansion unit and suggested actions to correct the detected problems.

<ul style="list-style-type: none"> <li>• Follow the suggested actions in the order in which they are listed in the Action column until the problem is solved.</li> <li>• See Chapter 3 “Parts listing” on page 33 to determine which components are consumable, structural, or CRU parts.</li> <li>• If an action step is preceded by “(trained technician only),” that step must be performed only by a trained technician.</li> </ul>		
Lit light path diagnostics LED	Description	Action
None	An error has occurred and cannot be isolated, or the service processor has failed.	<ol style="list-style-type: none"> <li>1. Make sure that the light path diagnostics LED is lit, to ensure that there is enough power in the blade server to light the rest of the LEDs. See “Viewing the light path diagnostics LEDs in the blade server” on page 164.</li> <li>2. Check the BMC log for information about an error that is not represented by a light path diagnostics LED. See “Using the Setup utility” on page 11.</li> </ol>
Battery error	The system battery is not installed or is not working.	<ol style="list-style-type: none"> <li>1. Reseat the battery. See “Removing the battery” on page 51 and “Installing the battery” on page 51.</li> <li>2. Replace the battery. See “Removing the battery” on page 51 and “Installing the battery” on page 51.</li> </ol>
DIMM x error	A memory error occurred.	Look for system-event and IMM/AMM logs related to memory and resolve those events (see “IMM error messages” on page 109 and “UEFI/POST error codes” on page 88).
Front panel missing error	The front control panel is not installed correctly.	Make sure that the front control panel is installed correctly and the control panel cable is installed securely on the system board (see “Installing the control panel” on page 67).
LP active	The system board light path LEDs have power.	Check for error LEDs that are lit on the system board. If this LED fails to light, install the blade server in a chassis for approximately 2 hours to enable the light path diagnostics panel to charge.



- Follow the suggested actions in the order in which they are listed in the Action column until the problem is solved.
- See Chapter 3 “Parts listing” on page 33 to determine which components are consumable, structural, or CRU parts.
- If an action step is preceded by “(trained technician only),” that step must be performed only by a trained technician.

Lit light path diagnostics LED	Description	Action
Microprocessor error	The microprocessor has failed or overheated, or the start microprocessor is missing.	<ol style="list-style-type: none"> <li>1. Check the Integrated Management Module (IMM) log for more information. See “Viewing event logs through the Setup utility” on page 86.</li> <li>2. If the log shows that a microprocessor is disabled or that a microprocessor error has occurred, perform one of the following actions:               <ol style="list-style-type: none"> <li>a. (Trained technician only) Reseat the microprocessor that is indicated by the lit LED. See “Removing a microprocessor and heat sink” on page 70 and “Installing a microprocessor and heat sink” on page 73.</li> <li>b. (Trained technician only) Replace the microprocessor that is indicated by the lit LED. See “Removing a microprocessor and heat sink” on page 70 and “Installing a microprocessor and heat sink” on page 73.</li> </ol> </li> </ol>
Microprocessor mismatch	Microprocessor mismatch.	<p>Make sure that microprocessors 1 and 2 are identical (number of cores, cache size and type, clock speed, internal and external clock frequencies).</p> <ol style="list-style-type: none"> <li>1. Verify the type of microprocessors installed by using the Configuration/Setup utility. See “Using the Setup utility” on page 11.</li> <li>2. (Trained technician only) Replace microprocessor 2 with an identical microprocessor to microprocessor 1. See “Removing a microprocessor and heat sink” on page 70 and “Installing a microprocessor and heat sink” on page 73.</li> </ol>
NMI error	The system board has failed.	<ol style="list-style-type: none"> <li>1. Replace the blade server cover, reinsert the blade server in the BladeCenter unit, and then restart the blade server. Check the BMC log for information about the error. See “Using the Setup utility” on page 11.</li> <li>2. (Trained technician only) Replace the system-board assembly. See “Removing the system-board assembly” on page 78 and “Installing the system-board assembly” on page 79.</li> </ol>

<ul style="list-style-type: none"> <li>• Follow the suggested actions in the order in which they are listed in the Action column until the problem is solved.</li> <li>• See Chapter 3 “Parts listing” on page 33 to determine which components are consumable, structural, or CRU parts.</li> <li>• If an action step is preceded by “(trained technician only),” that step must be performed only by a trained technician.</li> </ul>		
Lit light path diagnostics LED	Description	Action
SAS x error	A storage drive has failed.	Run the SAS Attached Disk diagnostic test. If the drives passes diagnostics but continues to have a problem, replace the storage drive with a new one. See “IBM Dynamic System Analysis Preboot diagnostic program” on page 170.
System board error	The system board has failed.	(Trained technician only) Replace the system-board assembly. See “Removing the system-board assembly” on page 78 and “Installing the system-board assembly” on page 79.
Temperature error	The system temperature has exceeded a threshold level.	<ol style="list-style-type: none"> <li>1. Check the function of the shared BladeCenter unit resources. See “Solving shared BladeCenter resource problems” on page 196.</li> <li>2. Make sure the air vents are not blocked and that all blade bays in the BladeCenter unit have a blade server or a blade filler installed.</li> <li>3. Make sure that the room temperature is not too high. See “Features and specifications” on page 2 for temperature information.</li> </ol>

## BladeCenter GPU expansion unit LED

The following illustration identifies the fault LED on the front of the BladeCenter GPU expansion (BGE) unit.

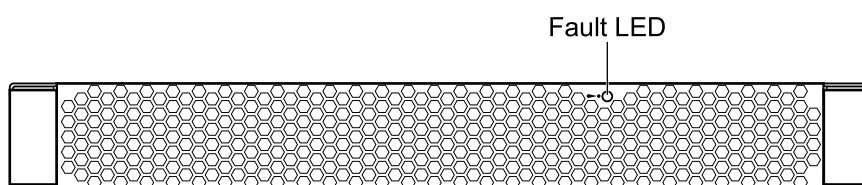

**Fault LED:** When this yellow LED is lit, it indicates that an error has occurred in the expansion blade. The expansion blade error LED turns off only after the error is corrected.

If an error occurs in the expansion blade, the fault LED on the blade device on which the expansion blade is installed is also lit. Additional information about the error is provided by the light-path LEDs in the expansion blade (see “BladeCenter GPU expansion unit light path diagnostics LEDs” on page 168 for more information).

## BladeCenter GPU expansion unit light path diagnostics LEDs

Use this information to diagnose and resolve possible errors displayed by the light path diagnostic LEDs in the BladeCenter GPU expansion unit.

The following table describes the LEDs on the expansion unit system board and suggested actions to correct the detected problems. Follow the suggested actions in the order in which they are listed in the Action column until the problem is solved.

<ul style="list-style-type: none"> <li>• Follow the suggested actions in the order in which they are listed in the Action column until the problem is solved.</li> <li>• See Chapter 3 “Parts listing” on page 33 to determine which components are consumable, structural, or CRU parts.</li> <li>• If an action step is preceded by “(trained technician only),” that step must be performed only by a trained technician.</li> </ul>		
Lit light path diagnostics LED	Description	Action
LP	The light path LEDs have power.	<p>If the LP LED is green, check for error LEDs that are lit in the expansion unit.</p> <p>If the LP LED is off, install the expansion unit on the blade server and install the combined assembly into the BladeCenter for 5 to 10 minutes to recharge the LEDs.</p>
None	An error has occurred and cannot be isolated.	<ol style="list-style-type: none"> <li>1. Make sure that the LP LED is lit to ensure that there is enough power in the expansion unit to light the rest of the LEDs.</li> <li>2. Check the event logs on the blade server and Advanced Management Module for information about an error that is not represented by a light path diagnostics LED.</li> </ol>
GPU	A GPU adapter error has occurred.	<ol style="list-style-type: none"> <li>1. Make sure that the GPU adapter installed in the PCIe connector is supported.</li> <li>2. Check the auxiliary power cable.</li> <li>3. Replace the GPU adapter installed in the PCIe connector.</li> <li>4. (Trained technician only) Replace the expansion unit.</li> </ol>
CFFh	A CFFh adapter error has occurred.	<ol style="list-style-type: none"> <li>1. Make sure that the adapter installed in the CFFh connector is supported.</li> <li>2. Reseat the adapter installed in the CFFh connector.</li> <li>3. Replace the adapter installed in the CFFh connector.</li> <li>4. (Trained technician only) Replace the expansion unit.</li> </ol>
BPE4	An error has occurred in the expansion unit.	<ol style="list-style-type: none"> <li>1. Check for other specific error LEDs that are lit in the expansion unit.</li> <li>2. (Trained technician only) If no other error LEDs are lit, replace the expansion unit.</li> </ol>
Ck Nxt	An error has occurred in an expansion unit installed below this expansion unit in the stack.	(Trained technician only) Remove this expansion unit and check for error LEDs that are lit in the expansion unit beneath it.

---

## IBM Dynamic System Analysis Preboot diagnostic program

IBM Dynamic System Analysis (DSA) Preboot diagnostic program collects and analyzes system information to aid in diagnosing blade server problems.

DSA Preboot might appear to be unresponsive when you start the program. This is normal operation while the program loads.

To diagnose and resolve DSA messages, see “Diagnostic messages” on page 171.

### Running the diagnostic programs

Use this information to run DSA Preboot.

**Important:** The DSA diagnostic programs do not support USB CD-ROM drives. If you run the DSA diagnostic programs while any USB CD-ROM drives are attached, ignore any optical drive test results that are returned for USB CD-ROM drives. You can also remove USB CD-ROM drives before you run the DSA diagnostic programs to get accurate optical drive test results.

To run the DSA Preboot diagnostic programs, complete the following steps:

1. If the blade server is running, turn off the blade server and all attached devices.
2. Turn on all attached devices; then, turn on the blade server.
3. When the prompt <F2 Diagnostics> is displayed, press F2.

**Note:** DSA Preboot might appear to be nonresponsive for an unusual length of time when you start the program. This is normal operation while the program loads.

4. Select **Quit to DSA** to exit from the stand-alone memory diagnostic program.

**Note:** After you exit from the stand-alone memory diagnostic environment, you must restart the blade server to access the stand-alone memory diagnostic environment again.

5. Enter **gui** to launch the DSA graphical user interface, or type **cmd** to display the DSA interactive menu.
6. From the diagnostic programs screen, select the test that you want to run and follow the instructions on the screen. For additional information, see the Dynamic System Analysis Installation and User's Guide, which is available at <http://www.ibm.com/support/entry/portal/docdisplay?Indocid=SERV-DSA>.

Help for DSA is available. For help about the DSA CLI, enter `help` from the command line. For help about the DSA user interface, press F1. Pressing F1 within a help panel displays additional online documentation.

To determine what action you should take as a result of a diagnostic text message or error code, see the table in “Diagnostic messages” on page 171.

If the diagnostic programs do not detect any hardware errors but the problem remains during normal server operations, a software error might be the cause. If you suspect a software problem, see the information that comes with your software.

A single problem might cause more than one error message. When this happens, correct the cause of the first error message. The other error messages usually will not occur the next time you run the diagnostic programs.

**Important:** If there are multiple error codes or light path diagnostics LEDs that indicate a microprocessor error, the error might be in a microprocessor or in a microprocessor socket.

If the blade server stops responding during testing and you cannot continue, restart the blade server and try running the diagnostic programs again. If the problem remains, replace the component that was being tested when the blade server stopped.

The diagnostic programs assume that a keyboard and mouse are attached to the BladeCenter unit and that the blade server controls them. If you run the diagnostic programs with either no mouse or a mouse attached to the BladeCenter unit that is not controlled by the blade server, you cannot use the **Next Cat** and **Prev Cat** buttons to select categories. All other mouse-selectable functions are available through function keys.

To view server configuration information such as system configuration, memory contents, interrupt request (IRQ) use, direct memory access (DMA) use, or device drivers, select **Hardware Info** from the top of the screen.

## Diagnostic text messages

Use this information to understand the diagnostic text messages that display while the tests are running.

A diagnostic text message contains one of the following results:

**Passed:** The test was completed without any errors.

**Failed:** The test detected an error.

**User Aborted:** You stopped the test before it was completed.

**Not Applicable:** You attempted to test a device that is not present in the blade server.

**Aborted:** The test could not proceed because of the blade server configuration.

**Warning:** The test could not be run. There was no failure of the hardware that was being tested, but there might be a hardware failure elsewhere, or another problem prevented the test from running; for example, there might be a configuration problem, or the hardware might be missing or is not being recognized.

The result is followed by an error code or other additional information about the error.

## Viewing the test results

Use this information to view the test results of the blade server.

You can use one of the following methods to access the test log when the tests are completed:

- From the DSA command line, issue the DSA CLI View command or select the Diagnostic Event Log option from the DSA graphical user interface (GUI)
- From the DSA interactive menu, select the `getextendedresults` option.
- From the DSA interactive menu, select the View option to view all of the collected results and error log data.
- In the DSA GUI, select DSA Error Log from the System Information page.

You can send the DSA error log file to IBM service and support to aid in diagnosing the server problems or you can use the DSA CLI `copy` command to copy the log to an external USB device.

## Diagnostic messages

Use this information to review the diagnostic error messages and resolve any errors that might occur in the blade server.

If the diagnostic programs generate error codes that are not listed in the table, make sure that the latest level of the UEFI code is installed. To download the latest firmware for the blade server, go to <http://www.ibm.com/systems/support/>.

The following table describes the messages that the diagnostic programs might generate and suggested actions to correct the detected problems. Follow the suggested actions in the order in which they are listed in the action column. In the error codes, x can be any numeral or letter. However, if the three-digit number in the central position of the code is 000, 195, or 197, *do not* replace a component. These numbers appearing in the central position of the code have the following meanings:

**000**

The blade server passed the test. Do not replace a component.

**195**

The Esc key was pressed to end the test. Do not replace a component.

**197**

This is a warning error, but it does not indicate a hardware failure; do not replace a component. Take the action that is indicated in the Action column, but *do not replace a component*. See the description for **Warning** in the section “Diagnostic text messages” on page 171 for more information.

## IMM self tests

Use this information to resolve IMM self-test errors by referencing the error codes and following the suggested corrective actions.

Follow the suggested actions in the order in which they are listed in the Action column until the problem is solved.

<ul style="list-style-type: none"> <li>• See Chapter 3 “Parts listing” on page 33 to determine which components are consumable, structural, or CRU parts.</li> <li>• If an action step is preceded by “(trained technician only),” that step must be performed only by a trained technician.</li> </ul>		
Error code	Description	Action
166-901-xxx	Failed the IMM test due to a failure in the Private bus (BUS 0).	<ol style="list-style-type: none"> <li>1. Turn off the blade server, open the blade server release levers and pull the blade server away from the blade server bay, but do not remove it. See “Removing the blade server from the BladeCenter unit” on page 41.</li> <li>2. Wait 45 seconds and reseat the blade server in the blade server bay and turn on the blade server. See “Installing the blade server in a BladeCenter unit” on page 41 and “Turning on the blade server” on page 6.</li> <li>3. Rerun the test. See “Diagnostic tools overview” on page 84.</li> <li>4. Make sure that the DSA Diagnostic code is up-to-date, upgrade if necessary; then, rerun the test. The latest code can be found on the IBM support website at <a href="http://www.ibm.com/support/docview.wss?uid=psg1SERV-DSA">http://www.ibm.com/support/docview.wss?uid=psg1SERV-DSA</a>.</li> <li>5. Make sure that the component firmware level is up-to-date, upgrade if necessary; then, rerun the test. The installed firmware level can be found in the DSA Diagnostic Event Log within the Firmware/VPD section for this component.</li> </ol>

- See Chapter 3 “Parts listing” on page 33 to determine which components are consumable, structural, or CRU parts.
- If an action step is preceded by “(trained technician only),” that step must be performed only by a trained technician.

Error code	Description	Action
		<p>The latest level firmware for this component can be found on the IBM support website at <a href="http://www.ibm.com/support/docview.wss?uid=psg1MIGR-4JTS2T">http://www.ibm.com/support/docview.wss?uid=psg1MIGR-4JTS2T</a>.</p> <ol style="list-style-type: none"> <li>6. Turn off the blade server and reseal the blade server in the blade server bay and turn on the blade server. See “Removing the blade server from the BladeCenter unit” on page 41, “Installing the blade server in a BladeCenter unit” on page 41, and “Turning on the blade server” on page 6.</li> <li>7. Rerun the test. See “Diagnostic tools overview” on page 84.</li> <li>8. If the failure remains, refer to Chapter 4 “Removing and replacing blade server components” on page 39 to replace the failed component.</li> </ol>
166-904-xxx	Failed the IMM self test due to a failure in the Lightpath bus (BUS 3).	<ol style="list-style-type: none"> <li>1. Turn off the blade server, open the blade server release levers and pull the blade server away from the blade server bay, but do not remove it. See “Removing the blade server from the BladeCenter unit” on page 41.</li> <li>2. Wait 45 seconds and reseal the blade server in the blade server bay and turn on the blade server. See “Installing the blade server in a BladeCenter unit” on page 41 and “Turning on the blade server” on page 6.</li> <li>3. Rerun the test. See “Diagnostic tools overview” on page 84.</li> <li>4. Make sure that the DSA Diagnostic code is up-to-date, upgrade if necessary; then, rerun the test. The latest code can be found on the IBM support website at <a href="http://www.ibm.com/support/docview.wss?uid=psg1SERV-DSA">http://www.ibm.com/support/docview.wss?uid=psg1SERV-DSA</a>.</li> <li>5. Make sure that the component firmware level is up-to-date, upgrade if necessary; then, rerun the test. The installed firmware level can be found in the DSA Diagnostic Event Log within the Firmware/VPD section for this component. The latest level firmware for this component can be found on the IBM support website at <a href="http://www.ibm.com/support/docview.wss?uid=psg1MIGR-4JTS2T">http://www.ibm.com/support/docview.wss?uid=psg1MIGR-4JTS2T</a>.</li> <li>6. Turn off the blade server and reseal the blade server in the blade server bay and turn on the blade server. See “Removing the blade server from the BladeCenter unit” on page 41, “Installing the blade server in a BladeCenter unit” on page 41, and “Turning on the blade server” on page 6.</li> </ol>

- See Chapter 3 “Parts listing” on page 33 to determine which components are consumable, structural, or CRU parts.
- If an action step is preceded by “(trained technician only),” that step must be performed only by a trained technician.

Error code	Description	Action
		<ol style="list-style-type: none"> <li>7. Rerun the test. See “Diagnostic tools overview” on page 84.</li> <li>8. If the failure remains, refer to Chapter 4 “Removing and replacing blade server components” on page 39 to replace the failed component.</li> </ol>
166-905-xxx	Failed the IMM self test due to a failure in the SAS/ServerRAID H1135 bus (BUS 4).	<ol style="list-style-type: none"> <li>1. Turn off the blade server, open the blade server release levers and pull the blade server away from the blade server bay, but do not remove it. See “Removing the blade server from the BladeCenter unit” on page 41.</li> <li>2. Wait 45 seconds and reseal the blade server in the blade server bay and turn on the blade server. See “Installing the blade server in a BladeCenter unit” on page 41 and “Turning on the blade server” on page 6.</li> <li>3. Rerun the test. See “Diagnostic tools overview” on page 84.</li> <li>4. Make sure that the DSA Diagnostic code is up-to-date, upgrade if necessary; then, rerun the test. The latest code can be found on the IBM support website at <a href="http://www.ibm.com/support/docview.wss?uid=psg1SERV-DSA">http://www.ibm.com/support/docview.wss?uid=psg1SERV-DSA</a>.</li> <li>5. Make sure that the component firmware level is up-to-date, upgrade if necessary; then, rerun the test. The installed firmware level can be found in the DSA Diagnostic Event Log within the Firmware/VPD section for this component. The latest level firmware for this component can be found on the IBM support website at <a href="http://www.ibm.com/support/docview.wss?uid=psg1MIGR-4JTS2T">http://www.ibm.com/support/docview.wss?uid=psg1MIGR-4JTS2T</a>.</li> <li>6. Turn off the blade server and reseal the blade server in the blade server bay and turn on the blade server. See “Removing the blade server from the BladeCenter unit” on page 41, “Installing the blade server in a BladeCenter unit” on page 41, and “Turning on the blade server” on page 6.</li> <li>7. Rerun the test. See “Diagnostic tools overview” on page 84.</li> <li>8. If the failure remains, refer to Chapter 4 “Removing and replacing blade server components” on page 39 to replace the failed component.</li> </ol>
166-908-xxx	Failed the IMM self test due to a failure in the EEPROM (BUS 7).	<ol style="list-style-type: none"> <li>1. Turn off the blade server, open the blade server release levers and pull the blade server away from the blade server bay, but do not remove it. See “Removing the blade server from the BladeCenter unit” on page 41.</li> </ol>



- See Chapter 3 “Parts listing” on page 33 to determine which components are consumable, structural, or CRU parts.
- If an action step is preceded by “(trained technician only),” that step must be performed only by a trained technician.

Error code	Description	Action
		<ol style="list-style-type: none"> <li>2. Wait 45 seconds and reseal the blade server in the blade server bay and turn on the blade server. See “Installing the blade server in a BladeCenter unit” on page 41 and “Turning on the blade server” on page 6.</li> <li>3. Rerun the test. See “Diagnostic tools overview” on page 84.</li> <li>4. Make sure that the DSA Diagnostic code is up-to-date, upgrade if necessary; then, rerun the test. The latest code can be found on the IBM support website at <a href="http://www.ibm.com/support/docview.wss?uid=psg1SERV-DSA">http://www.ibm.com/support/docview.wss?uid=psg1SERV-DSA</a>.</li> <li>5. Make sure that the component firmware level is up-to-date, upgrade if necessary; then, rerun the test. The installed firmware level can be found in the DSA Diagnostic Event Log within the Firmware/VPD section for this component. The latest level firmware for this component can be found on the IBM support website at <a href="http://www.ibm.com/support/docview.wss?uid=psg1MIGR-4JTS2T">http://www.ibm.com/support/docview.wss?uid=psg1MIGR-4JTS2T</a>.</li> <li>6. Turn off the blade server and reseal the blade server in the blade server bay and turn on the blade server. See “Removing the blade server from the BladeCenter unit” on page 41, “Installing the blade server in a BladeCenter unit” on page 41, and “Turning on the blade server” on page 6.</li> <li>7. Rerun the test. See “Diagnostic tools overview” on page 84.</li> <li>8. If the failure remains, refer to Chapter 4 “Removing and replacing blade server components” on page 39 to replace the failed component.</li> </ol>

## Broadcom Ethernet device tests

Use this information to resolve Broadcom Ethernet device errors.

Follow the suggested actions in the order in which they are listed in the Action column until the problem is solved.

- See Chapter 3 “Parts listing” on page 33 to determine which components are consumable, structural, or CRU parts.
- If an action step is preceded by “(Trained technician only),” that step must be performed only by a trained technician.

Error code	Description	Action
405-000-xxx	Passed the ControlRegisters test.	N/A
405-901-xxx	Failed the ControlRegisters test. A failure was detected while testing internal MAC registers.	<ol style="list-style-type: none"> <li>1. Make sure that the component firmware or driver is installed correctly, upgrade if necessary. The installed firmware level can be found in the DSA Diagnostic Event Log within the Firmware/VPD section for this component. The latest level firmware for this component can be found in reference to this system type at <a href="http://www.ibm.com/support/docview.wss?uid=psg1MIGR-4JTS2T">http://www.ibm.com/support/docview.wss?uid=psg1MIGR-4JTS2T</a>.</li> <li>2. Rerun the test.</li> <li>3. If the failure remains, refer to <a href="http://www.ibm.com/support/docview.wss?uid=psg1SERV-OPTN">http://www.ibm.com/support/docview.wss?uid=psg1SERV-OPTN</a> for the corrective actions.</li> </ol>
405-001-xxx	Passed the MIIRegisters test.	N/A
405-901-xxx	Failed the MIIRegisters test. A failure was detected while testing internal PHY registers.	<ol style="list-style-type: none"> <li>1. Make sure that the component firmware or driver is installed correctly, upgrade if necessary. The installed firmware level can be found in the DSA Diagnostic Event Log within the Firmware/VPD section for this component. The latest level firmware for this component can be found in reference to this system type at <a href="http://www.ibm.com/support/docview.wss?uid=psg1MIGR-4JTS2T">http://www.ibm.com/support/docview.wss?uid=psg1MIGR-4JTS2T</a>.</li> <li>2. Rerun the test.</li> <li>3. If the failure remains, refer to <a href="http://www.ibm.com/support/docview.wss?uid=psg1SERV-OPTN">http://www.ibm.com/support/docview.wss?uid=psg1SERV-OPTN</a> for the corrective actions.</li> </ol>
405-002-xxx	Passed the EEPROM test.	N/A
405-902-xxx	Failed the EEPROM test. A failure was detected while testing non-volatile RAM.	<ol style="list-style-type: none"> <li>1. Make sure that the component firmware or driver is installed correctly, upgrade if necessary. The installed firmware level can be found in the DSA Diagnostic Event Log within the Firmware/VPD section for this component. The latest level firmware for this component can be found in reference to this system type at <a href="http://www.ibm.com/support/docview.wss?uid=psg1MIGR-4JTS2T">http://www.ibm.com/support/docview.wss?uid=psg1MIGR-4JTS2T</a>.</li> <li>2. Rerun the test.</li> <li>3. If the failure remains, refer to <a href="http://www.ibm.com/support/docview.wss?uid=psg1SERV-OPTN">http://www.ibm.com/support/docview.wss?uid=psg1SERV-OPTN</a> for the corrective actions.</li> </ol>
405-003-xxx	Passed the InternalMemory test.	N/A

- See Chapter 3 “Parts listing” on page 33 to determine which components are consumable, structural, or CRU parts.
- If an action step is preceded by “(Trained technician only),” that step must be performed only by a trained technician.

Error code	Description	Action
405-903-xxx	Failed the InternalMemory test. A failure was detected while testing internal memory.	<ol style="list-style-type: none"> <li>1. Make sure that the component firmware or driver is installed correctly, upgrade if necessary. The installed firmware level can be found in the DSA Diagnostic Event Log within the Firmware/VPD section for this component. The latest level firmware for this component can be found in reference to this system type at <a href="http://www.ibm.com/support/docview.wss?uid=psg1MIGR-4JTS2T">http://www.ibm.com/support/docview.wss?uid=psg1MIGR-4JTS2T</a>.</li> <li>2. Rerun the test.</li> <li>3. If the failure remains, refer to <a href="http://www.ibm.com/support/docview.wss?uid=psg1SERV-OPTN">http://www.ibm.com/support/docview.wss?uid=psg1SERV-OPTN</a> for the corrective actions.</li> </ol>
405-004-xxx	Passed the Interrupt test.	N/A
405-904-xxx	Failed the Interrupt test. A failure was detected while testing interrupts.	<ol style="list-style-type: none"> <li>1. Make sure that the component firmware or driver is installed correctly, upgrade if necessary. The installed firmware level can be found in the DSA Diagnostic Event Log within the Firmware/VPD section for this component. The latest level firmware for this component can be found in reference to this system type at <a href="http://www.ibm.com/support/docview.wss?uid=psg1MIGR-4JTS2T">http://www.ibm.com/support/docview.wss?uid=psg1MIGR-4JTS2T</a>.</li> <li>2. Rerun the test.</li> <li>3. If the failure remains, refer to <a href="http://www.ibm.com/support/docview.wss?uid=psg1SERV-OPTN">http://www.ibm.com/support/docview.wss?uid=psg1SERV-OPTN</a> for the corrective actions.</li> </ol>
405-005-xxx	Passed the LoopbackAtMACLayer test.	N/A
405-905-xxx	Failed the LoopbackAtMACLayer test. A failure was detected during the loopback test at the MAC layer.	<ol style="list-style-type: none"> <li>1. Make sure that the component firmware or driver is installed correctly, upgrade if necessary. The installed firmware level can be found in the DSA Diagnostic Event Log within the Firmware/VPD section for this component. The latest level firmware for this component can be found in reference to this system type at <a href="http://www.ibm.com/support/docview.wss?uid=psg1MIGR-4JTS2T">http://www.ibm.com/support/docview.wss?uid=psg1MIGR-4JTS2T</a>.</li> <li>2. Rerun the test.</li> <li>3. If the failure remains, refer to <a href="http://www.ibm.com/support/docview.wss?uid=psg1SERV-OPTN">http://www.ibm.com/support/docview.wss?uid=psg1SERV-OPTN</a> for the corrective actions.</li> </ol>
405-006-xxx	Passed the LoopbackAtPhysicallayer test.	N/A

- See Chapter 3 “Parts listing” on page 33 to determine which components are consumable, structural, or CRU parts.
- If an action step is preceded by “(Trained technician only),” that step must be performed only by a trained technician.

Error code	Description	Action
405-906-xxx	Failed the LoopbackAtPhysicallayer test. A failure was detected during the loopback test at the physical layer.	<ol style="list-style-type: none"> <li>1. Make sure that the component firmware or driver is installed correctly, upgrade if necessary. The installed firmware level can be found in the DSA Diagnostic Event Log within the Firmware/VPD section for this component. The latest level firmware for this component can be found in reference to this system type at <a href="http://www.ibm.com/support/docview.wss?uid=psg1MIGR-4JTS2T">http://www.ibm.com/support/docview.wss?uid=psg1MIGR-4JTS2T</a>.</li> <li>2. Rerun the test.</li> <li>3. If the failure remains, refer to <a href="http://www.ibm.com/support/docview.wss?uid=psg1SERV-OPTN">http://www.ibm.com/support/docview.wss?uid=psg1SERV-OPTN</a> for the corrective actions.</li> </ol>
405-006-xxx	Passed the LEDs test.	N/A
405-906-xxx	Failed the LEDs test. A failure was detected while verifying operation of the status LEDs.	<ol style="list-style-type: none"> <li>1. Make sure that the component firmware or driver is installed correctly, upgrade if necessary. The installed firmware level can be found in the DSA Diagnostic Event Log within the Firmware/VPD section for this component. The latest level firmware for this component can be found in reference to this system type at <a href="http://www.ibm.com/support/docview.wss?uid=psg1MIGR-4JTS2T">http://www.ibm.com/support/docview.wss?uid=psg1MIGR-4JTS2T</a>.</li> <li>2. Rerun the test.</li> <li>3. If the failure remains, refer to <a href="http://www.ibm.com/support/docview.wss?uid=psg1SERV-OPTN">http://www.ibm.com/support/docview.wss?uid=psg1SERV-OPTN</a> for the corrective actions.</li> </ol>

## CPU stress tests

Use this information to view CPU stress test error codes and resolve CPU stress test errors.

Follow the suggested actions in the order in which they are listed in the Action column until the problem is solved.

- See Chapter 3 “Parts listing” on page 33 to determine which components are consumable, structural, or CRU parts.
- If an action step is preceded by “(trained technician only),” that step must be performed only by a trained technician.

Error code	Description	Action
089-801-xxx	Aborted due to an internal program error.	<ol style="list-style-type: none"> <li>1. If the blade server has stopped responding, turn off and restart the blade server. See “Turning off the blade server” on page 7 and “Turning on the blade server” on page 6.</li> <li>2. Make sure that the DSA Diagnostic code is up-to-date, upgrade if necessary; then, rerun the test. The latest code can be found on the</li> </ol>

- See Chapter 3 “Parts listing” on page 33 to determine which components are consumable, structural, or CRU parts.
- If an action step is preceded by “(trained technician only),” that step must be performed only by a trained technician.

Error code	Description	Action
		<p>IBM support website at <a href="http://www.ibm.com/support/docview.wss?uid=psg1SERV-DSA">http://www.ibm.com/support/docview.wss?uid=psg1SERV-DSA</a>.</p> <ol style="list-style-type: none"> <li>3. Make sure that the system firmware level is up-to-date, upgrade if necessary; then, rerun the test. The installed firmware level can be found in the DSA Diagnostic Event Log within the Firmware/VPD section for this component. The latest level firmware for this component can be found on the IBM support Web site at <a href="http://www.ibm.com/support/docview.wss?uid=psg1MIGR-63017">http://www.ibm.com/support/docview.wss?uid=psg1MIGR-63017</a>.</li> <li>4. If the blade server has stopped responding, turn off and restart the blade server; then, rerun the test. See “Turning off the blade server” on page 7 and “Turning on the blade server” on page 6.</li> <li>5. (Trained technician only) If the component failure remains, refer to Chapter 4 “Removing and replacing blade server components” on page 39 to replace the failed component.</li> </ol>
089-802-xxx	Aborted due a system resource availability error.	<ol style="list-style-type: none"> <li>1. If the blade server has stopped responding, turn off and restart the blade server. See “Turning off the blade server” on page 7 and “Turning on the blade server” on page 6.</li> <li>2. Make sure that the DSA Diagnostic code is up-to-date, upgrade if necessary; then, rerun the test. The latest code can be found on the IBM support Web site at <a href="http://www.ibm.com/support/docview.wss?uid=psg1SERV-DSA">http://www.ibm.com/support/docview.wss?uid=psg1SERV-DSA</a>.</li> <li>3. Make sure that the system firmware level is up-to-date, upgrade if necessary; then, rerun the test. The installed firmware level can be found in the DSA Diagnostic Event Log within the Firmware/VPD section for this component. The latest level firmware for this component can be found on the IBM support Web site at <a href="http://www.ibm.com/systems/support/supportsite.wss/docdispl">http://www.ibm.com/systems/support/supportsite.wss/docdispl</a>.</li> <li>4. If the blade server has stopped responding, turn off and restart the blade server; then, rerun the test. See “Turning off the blade server” on page 7 and “Turning on the blade server” on page 6.</li> <li>5. (Trained technician only) If the component failure remains, refer to Chapter 4 “Removing and replacing blade server components” on page 39 to replace the failed component.</li> </ol>
089-901-xxx	Failed the CPU stress test.	<ol style="list-style-type: none"> <li>1. If the blade server has stopped responding, turn off and restart the blade server; then, rerun the test. See “Turning off the blade server” on page 7 and “Turning on the blade server” on page 6.</li> <li>2. Make sure that the DSA Diagnostic code is up-to-date, upgrade if necessary; then, rerun</li> </ol>

- See Chapter 3 “Parts listing” on page 33 to determine which components are consumable, structural, or CRU parts.
- If an action step is preceded by “(trained technician only),” that step must be performed only by a trained technician.

Error code	Description	Action
		<p>the test. up-to-date, upgrade if necessary. The latest code can be found on the IBM support Web site at <a href="http://www.ibm.com/support/docview.wss?uid=psg1SERV-DSA">http://www.ibm.com/support/docview.wss?uid=psg1SERV-DSA</a>.</p> <ol style="list-style-type: none"> <li>3. Make sure that the system firmware level is up-to-date, upgrade if necessary; then, rerun the test. The installed firmware level can be found in the DSA Diagnostic Event Log within the Firmware/VPD section for this component. The latest level firmware for this component can be found on the IBM support Web site at <a href="http://www.ibm.com/systems/support/supportsite.wss/docdisplay?">http://www.ibm.com/systems/support/supportsite.wss/docdisplay?</a></li> <li>4. If the blade server has stopped responding, turn off and restart the blade server; then, rerun the test.</li> <li>5. (Trained technician only) If the component failure remains, refer to Chapter 4 “Removing and replacing blade server components” on page 39 to replace the failed component.</li> </ol>

## Memory self tests

Use this information to diagnose and resolve memory-self test errors.

Follow the suggested actions in the order in which they are listed in the Action column until the problem is solved.

- See Chapter 3 “Parts listing” on page 33 to determine which components are consumable, structural, or CRU parts.
- If an action step is preceded by “(trained technician only),” that step must be performed only by a trained technician.

Error code	Description	Action
210-000-000	Passed the memory self test.	N/A
201-811-xxx	Aborted the memory self test because the test was unable to locate the _SM_ key when locating the SMBIOS structure data.	<ol style="list-style-type: none"> <li>1. If the blade server has stopped responding, turn off and restart the blade server; then, rerun the test. See “Turning off the blade server” on page 7, “Turning on the blade server” on page 6 and “Diagnostic tools overview” on page 84.</li> <li>2. Make sure that the system BIOS firmware is at the latest level, upgrade if necessary; then, rerun the test ( “Diagnostic tools overview” on page 84). The BIOS firmware level can be found in the DSA Diagnostic Event Log within the Firmware/VPD section for this component. The latest level firmware for this component can be found on the IBM support Web site at <a href="http://www.ibm.com/support/docview.wss?uid=psg1MIGR-63017">http://www.ibm.com/support/docview.wss?uid=psg1MIGR-63017</a>.</li> </ol>

- See Chapter 3 “Parts listing” on page 33 to determine which components are consumable, structural, or CRU parts.
- If an action step is preceded by “(trained technician only),” that step must be performed only by a trained technician.

Error code	Description	Action
		<ol style="list-style-type: none"> <li>3. Rerun the test. See “Diagnostic tools overview” on page 84.</li> <li>4. If the component failure remains, refer to Chapter 4 “Removing and replacing blade server components” on page 39 to replace the failed component.</li> <li>5. Rerun the test. See “Diagnostic tools overview” on page 84.</li> </ol>
201-812-xxx	Aborted the memory self test because the SMBIOS type 0 structure indicates a non-supported, invalid machine ID.	<ol style="list-style-type: none"> <li>1. If the blade server has stopped responding, turn off and restart the blade server; then, rerun the test. See “Turning off the blade server” on page 7, “Turning on the blade server” on page 6 and “Diagnostic tools overview” on page 84.</li> <li>2. Make sure that the system BIOS firmware is at the latest level, upgrade if necessary; then, rerun the test ( “Diagnostic tools overview” on page 84). The BIOS firmware level can be found in the DSA Diagnostic Event Log within the Firmware/VPD section for this component. The latest level firmware for this component can be found on the IBM support Web site at <a href="http://www.ibm.com/support/docview.wss?uid=psg1MIGR-63017">http://www.ibm.com/support/docview.wss?uid=psg1MIGR-63017</a>.</li> <li>3. If the component failure remains, refer to Chapter 4 “Removing and replacing blade server components” on page 39 to replace the failed component.</li> <li>4. Rerun the test.</li> </ol>
201-815-xxx	Aborted the memory self test because of a programming error in the Quick Memory menu item selection process.	<ol style="list-style-type: none"> <li>1. If the blade server has stopped responding, turn off and restart the blade server; then, rerun the test. See “Turning off the blade server” on page 7, “Turning on the blade server” on page 6 and “Diagnostic tools overview” on page 84.</li> <li>2. Make sure that the DSA Diagnostic code is at the latest level; then, rerun the test ( “Diagnostic tools overview” on page 84). The latest code can be found on the IBM support Web site at <a href="http://www.ibm.com/support/docview.wss?uid=psg1SERV-DSA">http://www.ibm.com/support/docview.wss?uid=psg1SERV-DSA</a>.</li> <li>3. Make sure that the system BIOS firmware is at the latest level, upgrade if necessary; then, rerun the test ( “Diagnostic tools overview” on page 84). The BIOS firmware level can be found in the DSA Diagnostic Event Log within the Firmware/VPD section for this component. The latest level firmware for this component can be found on the IBM support Web site at <a href="http://www.ibm.com/support/docview.wss?uid=psg1MIGR-63017">http://www.ibm.com/support/docview.wss?uid=psg1MIGR-63017</a>.</li> </ol>

- See Chapter 3 “Parts listing” on page 33 to determine which components are consumable, structural, or CRU parts.
- If an action step is preceded by “(trained technician only),” that step must be performed only by a trained technician.

Error code	Description	Action
		<ol style="list-style-type: none"> <li>4. If the component failure remains, refer to Chapter 4 “Removing and replacing blade server components” on page 39 to replace the failed component.</li> </ol>
201-818-xxx	Aborted the memory self test because the test was unable to locate the _SM_ key when locating the SMBIOS structure data for the memory information.	<ol style="list-style-type: none"> <li>1. If the blade server has stopped responding, turn off and restart the blade server; then, rerun the test. See “Turning off the blade server” on page 7, “Turning on the blade server” on page 6 and “Diagnostic tools overview” on page 84.</li> <li>2. Make sure that the system BIOS firmware is at the latest level, upgrade if necessary; then, rerun the test ( “Diagnostic tools overview” on page 84). The BIOS firmware level can be found in the DSA Diagnostic Event Log within the Firmware/VPD section for this component. The latest level firmware for this component can be found on the IBM support Web site at <a href="http://www.ibm.com/support/docview.wss?uid=psg1MIGR-63017">http://www.ibm.com/support/docview.wss?uid=psg1MIGR-63017</a>.</li> <li>3. If the component failure remains, refer to Chapter 4 “Removing and replacing blade server components” on page 39 to replace the failed component.</li> </ol>
201-819-xxx	Aborted the memory self test because the START-END address ranges are located in the restricted area of memory.	<ol style="list-style-type: none"> <li>1. If the blade server has stopped responding, turn off and restart the blade server; then, rerun the test. See “Turning off the blade server” on page 7, “Turning on the blade server” on page 6 and “Diagnostic tools overview” on page 84.</li> <li>2. Make sure that the DSA Diagnostic code is at the latest level; then, rerun the test ( “Diagnostic tools overview” on page 84). The latest code can be found on the IBM support Web site at <a href="http://www.ibm.com/support/docview.wss?uid=psg1SERV-DSA">http://www.ibm.com/support/docview.wss?uid=psg1SERV-DSA</a>.</li> <li>3. Make sure that the system BIOS firmware is at the latest level, upgrade if necessary; then, rerun the test ( “Diagnostic tools overview” on page 84). The BIOS firmware level can be found in the DSA Diagnostic Event Log within the Firmware/VPD section for this component. The latest level firmware for this component can be found on the IBM support Web site at <a href="http://www.ibm.com/support/docview.wss?uid=psg1MIGR-63017">http://www.ibm.com/support/docview.wss?uid=psg1MIGR-63017</a>.</li> <li>4. If the component failure remains, refer to Chapter 4 “Removing and replacing blade server components” on page 39 to replace the failed component.</li> </ol>



- See Chapter 3 “Parts listing” on page 33 to determine which components are consumable, structural, or CRU parts.
- If an action step is preceded by “(trained technician only),” that step must be performed only by a trained technician.

Error code	Description	Action
201-877-xxx	Aborted the memory self test because the Mirroring feature is enabled.	<ol style="list-style-type: none"> <li>1. If the blade server has stopped responding, turn off and restart the blade server. See “Turning off the blade server” on page 7, “Turning on the blade server” on page 6.</li> <li>2. Press F1 during start up and turn off the Mirroring feature; then, rerun the test. See “Diagnostic tools overview” on page 84.</li> <li>3. Make sure that the system BIOS firmware is at the latest level, upgrade if necessary; then, rerun the test ( “Diagnostic tools overview” on page 84). The BIOS firmware level can be found in the DSA Diagnostic Event Log within the Firmware/VPD section for this component. The latest level firmware for this component can be found on the IBM support Web site at <a href="http://www.ibm.com/support/docview.wss?uid=psg1MIGR-63017">http://www.ibm.com/support/docview.wss?uid=psg1MIGR-63017</a>.</li> <li>4. If the component failure remains, refer to Chapter 4 “Removing and replacing blade server components” on page 39 to replace the failed component.</li> </ol>
201-878-xxx	Aborted the memory self test because the Sparing feature is enabled.	<ol style="list-style-type: none"> <li>1. If the blade server has stopped responding, turn off and restart the blade server. See “Turning off the blade server” on page 7, “Turning on the blade server” on page 6.</li> <li>2. Press F1 during start up and turn off the Sparing feature; then, rerun the test. See “Diagnostic tools overview” on page 84.</li> <li>3. Make sure that the system BIOS firmware is at the latest level, upgrade if necessary; then, rerun the test ( “Diagnostic tools overview” on page 84). The BIOS firmware level can be found in the DSA Diagnostic Event Log within the Firmware/VPD section for this component. The latest level firmware for this component can be found on the IBM support website at <a href="http://www.ibm.com/support/docview.wss?uid=psg1MIGR-63017">http://www.ibm.com/support/docview.wss?uid=psg1MIGR-63017</a>.</li> <li>4. If the component failure remains, refer to Chapter 4 “Removing and replacing blade server components” on page 39 to replace the failed component.</li> </ol>

- See Chapter 3 “Parts listing” on page 33 to determine which components are consumable, structural, or CRU parts.
- If an action step is preceded by “(trained technician only),” that step must be performed only by a trained technician.

Error code	Description	Action
201-885-xxx	Aborted the memory self test because the microprocessor does not support MTRR functions and cannot de-cache available memory.	<ol style="list-style-type: none"> <li>1. If the blade server has stopped responding, turn off and restart the blade server; then, rerun the test. See “Turning off the blade server” on page 7, “Turning on the blade server” on page 6 and “Diagnostic tools overview” on page 84.</li> <li>2. Make sure that the DSA Diagnostic code is at the latest level; then, rerun the test ( “Diagnostic tools overview” on page 84). The latest code can be found on the IBM support Web site at <a href="http://www.ibm.com/support/docview.wss?uid=psg1SERV-DSA">http://www.ibm.com/support/docview.wss?uid=psg1SERV-DSA</a>.</li> <li>3. Make sure that the system BIOS firmware is at the latest level, upgrade if necessary; then, rerun the test ( “Diagnostic tools overview” on page 84). The BIOS firmware level can be found in the DSA Diagnostic Event Log within the Firmware/VPD section for this component. The latest level firmware for this component can be found on the IBM support Web site at <a href="http://www.ibm.com/support/docview.wss?uid=psg1MIGR-63017">http://www.ibm.com/support/docview.wss?uid=psg1MIGR-63017</a>.</li> <li>4. If the component failure remains, refer to Chapter 4 “Removing and replacing blade server components” on page 39 to replace the failed component.</li> </ol>
201-886-xxx	Aborted due to a program error in the E820 function call, which indicates there is not enough available memory for testing.	<ol style="list-style-type: none"> <li>1. If the blade server has stopped responding, turn off and restart the blade server; then, rerun the test. See “Turning off the blade server” on page 7, “Turning on the blade server” on page 6 and “Diagnostic tools overview” on page 84.</li> <li>2. Make sure that the system BIOS firmware is at the latest level, upgrade if necessary; then, rerun the test ( “Diagnostic tools overview” on page 84). The BIOS firmware level can be found in the DSA Diagnostic Event Log within the Firmware/VPD section for this component. The latest level firmware for this component can be found on the IBM support Web site at <a href="http://www.ibm.com/support/docview.wss?uid=psg1MIGR-63017">http://www.ibm.com/support/docview.wss?uid=psg1MIGR-63017</a>.</li> <li>3. If the component failure remains, refer to Chapter 4 “Removing and replacing blade server components” on page 39 to replace the failed component.</li> </ol>

- See Chapter 3 “Parts listing” on page 33 to determine which components are consumable, structural, or CRU parts.
- If an action step is preceded by “(trained technician only),” that step must be performed only by a trained technician.

Error code	Description	Action
201-894-xxx	Aborted due to an unexpected error code.	<ol style="list-style-type: none"> <li>1. If the blade server has stopped responding, turn off and restart the blade server; then, rerun the test. See “Turning off the blade server” on page 7, “Turning on the blade server” on page 6 and “Diagnostic tools overview” on page 84.</li> <li>2. Make sure that the DSA Diagnostic code is at the latest level; then, rerun the test ( “Diagnostic tools overview” on page 84). The latest code can be found on the IBM support Web site at <a href="http://www.ibm.com/support/docview.wss?uid=psg1SERV-DSA">http://www.ibm.com/support/docview.wss?uid=psg1SERV-DSA</a>.</li> <li>3. Make sure that the system BIOS firmware is at the latest level, upgrade if necessary; then, rerun the test ( “Diagnostic tools overview” on page 84). The BIOS firmware level can be found in the DSA Diagnostic Event Log within the Firmware/VPD section for this component. The latest level firmware for this component can be found on the IBM support Web site at <a href="http://www.ibm.com/support/docview.wss?uid=psg1MIGR-63017">http://www.ibm.com/support/docview.wss?uid=psg1MIGR-63017</a>.</li> <li>4. If the component failure remains, refer to Chapter 4 “Removing and replacing blade server components” on page 39 to replace the failed component.</li> </ol>
201-899-xxx	The memory self test was aborted by the user.	The memory self test was terminated by the user before test completion.
201-901-xxx	Failed the memory self test due to a single-bit error in DIMM x OR failed the memory self test due to a multi-bit error in DIMMs x and y.	<ol style="list-style-type: none"> <li>1. If the blade server has stopped responding, turn off the blade server and pull it out of the bay to disconnect it from power. See “Turning off the blade server” on page 7 and “Removing the blade server from the BladeCenter unit” on page 41.</li> <li>2. Reseat DIMM x. See “Removing a memory module” on page 54 and “Installing a memory module” on page 55.</li> <li>3. Return the blade server to the blade server bay and turn on the blade server. See “Installing the blade server in a BladeCenter unit” on page 41 and “Turning on the blade server” on page 6.</li> <li>4. Make sure that the DSA Diagnostic code is at the latest level; then, rerun the test ( “Diagnostic tools overview” on page 84). The latest code can be found on the IBM support Web site at <a href="http://www.ibm.com/support/docview.wss?uid=psg1SERV-DSA">http://www.ibm.com/support/docview.wss?uid=psg1SERV-DSA</a>.</li> <li>5. Make sure that the system BIOS firmware is at the latest level, upgrade if necessary; then, rerun the test ( “Diagnostic tools overview” on page 84). The BIOS firmware level can be found in the DSA Diagnostic Event Log within</li> </ol>

- See Chapter 3 “Parts listing” on page 33 to determine which components are consumable, structural, or CRU parts.
- If an action step is preceded by “(trained technician only),” that step must be performed only by a trained technician.

Error code	Description	Action
		<p>the Firmware/VPD section for this component. The latest level firmware for this component can be found on the IBM support Web site at <a href="http://www.ibm.com/support/docview.wss?uid=psg1MIGR-63017">http://www.ibm.com/support/docview.wss?uid=psg1MIGR-63017</a>.</p> <ol style="list-style-type: none"> <li>6. If the component failure remains, refer to Chapter 4 “Removing and replacing blade server components” on page 39 to replace the failing DIMMs.</li> <li>7. Return the blade server to the blade server bay ( “Installing the blade server in a BladeCenter unit” on page 41), press F1 during start up and in the <b>Setup utility &gt; Resource Utilization</b> section, click <b>Available System Memory</b> to re-enable all memory; then, rerun the test ( “Diagnostic tools overview” on page 84).</li> </ol>

## Optical drive self tests

Use this information to diagnose and resolve optical drive self-test errors.

Follow the suggested actions in the order in which they are listed in the Action column until the problem is solved.

- See Chapter 3 “Parts listing” on page 33 to determine which components are consumable, structural, or CRU parts.
- If an action step is preceded by “(trained technician only),” that step must be performed only by a trained technician.

Error code	Description	Action
215-000-xxx	Passed the optical drive self test.	N/A
215-801-xxx	Aborted the optical drive self test because it was unable to communicate with the device driver.	<ol style="list-style-type: none"> <li>1. Make sure that the DSA Diagnostic code is at the latest level, upgrade if necessary; then, rerun the test ( “Diagnostic tools overview” on page 84). The latest code can be found IBM support Web site at <a href="http://www.ibm.com/support/docview.wss?uid=psg1SERV-DSA">http://www.ibm.com/support/docview.wss?uid=psg1SERV-DSA</a>.</li> <li>2. Make sure that the cable for the optical drive is securely connected at both ends of the cable, then; tighten any loose connections. See your BladeCenter documentation for information about replacing the optical drive (media tray).</li> <li>3. Make sure that the cable for the optical drive is not damaged, then; replace the cable if damage is present. See your BladeCenter documentation for information about replacing the optical drive.</li> <li>4. Rerun the test. See “Diagnostic tools overview” on page 84.</li> </ol>

- See Chapter 3 “Parts listing” on page 33 to determine which components are consumable, structural, or CRU parts.
- If an action step is preceded by “(trained technician only),” that step must be performed only by a trained technician.

Error code	Description	Action
		<ol style="list-style-type: none"> <li>5. For additional troubleshooting information, go to <a href="http://www-947.ibm.com/support/entry/portal/docdisplay?Indoc">http://www-947.ibm.com/support/entry/portal/docdisplay?Indoc</a></li> <li>6. Make sure that the system firmware level is at the latest level and upgrade if necessary; then, rerun the test. The installed firmware level can be found in the DSA Diagnostic Event Log within the Firmware/VPD section for this component. The latest level firmware for this component can be found on the IBM support Web site at <a href="http://www.ibm.com/support/docview.wss?uid=psg1MIGR-63017">http://www.ibm.com/support/docview.wss?uid=psg1MIGR-63017</a></li> <li>7. Rerun the test. See “Diagnostic tools overview” on page 84.</li> <li>8. Replace the CD or DVD drive. See your BladeCenter documentation for information about replacing the optical drive (media tray).</li> <li>9. If the failure remains, collect the data from the DSA event log and sent it to IBM Service. For information about contacting and sending data to IBM Service, see “Hardware service and support” on page 205.</li> </ol>
215-802-xxx	Aborted the optical drive self test due to media tray being open.	<ol style="list-style-type: none"> <li>1. Close the media tray and wait 15 seconds. See your BladeCenter documentation for information about the optical drive (media tray).</li> <li>2. Rerun the test. See “Diagnostic tools overview” on page 84.</li> <li>3. Insert a new CD or DVD into the drive and wait for 15 seconds for the media to be recognized; then, rerun the test. See “Diagnostic tools overview” on page 84.</li> <li>4. Make sure that the cable for the optical drive is securely connected at both ends of the cable and tighten any loose connections. See your BladeCenter documentation for information about the optical drive (media tray).</li> <li>5. Make sure that the cable for the optical drive is not damaged and replace the cable if damage is present. See your BladeCenter documentation for information about the optical drive (media tray).</li> <li>6. Rerun the test. See “Diagnostic tools overview” on page 84.</li> <li>7. Make sure that the DSA Diagnostic code is at the latest level, upgrade if necessary. The latest code can be found at <a href="http://www.ibm.com/support/docview.wss?uid=psg1SERV-DSA">http://www.ibm.com/support/docview.wss?uid=psg1SERV-DSA</a></li> <li>8. Rerun the test. See “Diagnostic tools overview” on page 84.</li> </ol>

- See Chapter 3 “Parts listing” on page 33 to determine which components are consumable, structural, or CRU parts.
- If an action step is preceded by “(trained technician only),” that step must be performed only by a trained technician.

Error code	Description	Action
		<ol style="list-style-type: none"> <li>9. For additional troubleshooting information, go to <a href="http://www-947.ibm.com/support/entry/portal/docdisplay?Indocid=">http://www-947.ibm.com/support/entry/portal/docdisplay?Indocid=</a></li> <li>10. Rerun the test. See “Diagnostic tools overview” on page 84.</li> <li>11. Replace the CD or DVD drive (media tray). See your BladeCenter documentation for information about replacing the optical drive.</li> <li>12. If the failure remains, collect the data from the DSA event log and send it to IBM Service. For information about contacting and sending data to IBM Service, see “Hardware service and support” on page 205.</li> </ol>
215-803-xxx	Failed the optical drive self test due to the disk possibly being in use by the system.	<ol style="list-style-type: none"> <li>1. Wait for the system activity to stop; then, rerun the test. See .</li> <li>2. Turn off and turn on the system, then; rerun the test. See “Turning off the blade server” on page 7, “Turning on the blade server” on page 6 and “Diagnostic tools overview” on page 84.</li> <li>3. If the component failure remains, see your BladeCenter documentation for information about replacing the optical drive (media tray).</li> <li>4. If the failure remains, collect the data from the DSA event log ( “Diagnostic tools overview” on page 84) and send it to IBM Service. For information about contacting and sending data to IBM Service, see “Hardware service and support” on page 205.</li> </ol>
215-901-xxx	Aborted the optical drive self test because the drive media was not detected.	<ol style="list-style-type: none"> <li>1. Insert a new CD or DVD into the drive and wait for 15 seconds for the media to be recognized; then, rerun the test. See “Diagnostic tools overview” on page 84.</li> <li>2. Make sure that the cable for the optical drive is securely connected at both ends of the cable and tighten any loose connections. See your BladeCenter documentation for information about the optical drive (media tray).</li> <li>3. Make sure that the cable for the optical drive is not damaged and replace the cable if damage is present. See your BladeCenter documentation for information about the optical drive (media tray).</li> <li>4. Rerun the test. See “Diagnostic tools overview” on page 84.</li> <li>5. For additional troubleshooting information, go to <a href="http://www-947.ibm.com/support/entry/portal/docdisplay?Indocid=">http://www-947.ibm.com/support/entry/portal/docdisplay?Indocid=</a></li> <li>6. Rerun the test. See “Diagnostic tools overview” on page 84.</li> </ol>

- See Chapter 3 “Parts listing” on page 33 to determine which components are consumable, structural, or CRU parts.
- If an action step is preceded by “(trained technician only),” that step must be performed only by a trained technician.

Error code	Description	Action
		<ol style="list-style-type: none"> <li>7. Replace the CD or DVD drive. See your BladeCenter documentation for information about replacing the optical drive (media tray).</li> <li>8. If the failure remains, collect the data from the DSA event log ( “Diagnostic tools overview” on page 84) and send it to IBM Service. For information about contacting and sending data to IBM Service, see “Hardware service and support” on page 205.</li> </ol>
215-902-xxx	Failed the optical drive self test due to a read mismatch.	<ol style="list-style-type: none"> <li>1. Insert a new CD or DVD into the drive and wait for 15 seconds for the media to be recognized; then, rerun the test. See “Diagnostic tools overview” on page 84.</li> <li>2. Make sure that the cable for the optical drive is securely connected at both ends of the cable and tighten any loose connections. See your BladeCenter documentation for information about the optical drive (media tray).</li> <li>3. Make sure that the cable for the optical drive is not damaged and replace the cable if damage is present. See your BladeCenter documentation for information about the optical drive (media tray).</li> <li>4. Rerun the test. See “Diagnostic tools overview” on page 84.</li> <li>5. For additional troubleshooting information, go to <a href="http://www-947.ibm.com/support/entry/portal/docdisplay?Indoc">http://www-947.ibm.com/support/entry/portal/docdisplay?Indoc</a></li> <li>6. Rerun the test. See “Diagnostic tools overview” on page 84.</li> <li>7. Replace the CD or DVD drive. See your BladeCenter documentation for information about replacing the optical drive (media tray).</li> <li>8. If the failure remains, collect the data from the DSA event log and send it to IBM Service. For information about contacting and sending data to IBM Service, see “Hardware service and support” on page 205.</li> </ol>
215-903-xxx	Aborted the optical drive self test because the drive could not be accessed.	<ol style="list-style-type: none"> <li>1. Insert a new CD or DVD into the optical drive and wait for 15 seconds for the media to be recognized; then, rerun the test. See “Diagnostic tools overview” on page 84.</li> <li>2. Make sure that the cable for the optical drive is securely connected at both ends of the cable. See your BladeCenter documentation for information about the optical drive (media tray).</li> <li>3. Make sure that the cable for the optical drive is not damaged; then, replace the cable if damage is present. See your BladeCenter</li> </ol>

- See Chapter 3 “Parts listing” on page 33 to determine which components are consumable, structural, or CRU parts.
- If an action step is preceded by “(trained technician only),” that step must be performed only by a trained technician.

Error code	Description	Action
		<p>documentation for information about replacing the optical drive (media tray).</p> <ol style="list-style-type: none"> <li>4. Make sure that the DSA Diagnostic code is at the latest level and upgrade if necessary; then, rerun the test. The latest code can be found on the IBM support Web site at <a href="http://www.ibm.com/support/docview.wss?uid=psg1SERV-DSA">http://www.ibm.com/support/docview.wss?uid=psg1SERV-DSA</a>.</li> <li>5. For additional troubleshooting information, go to <a href="http://www-947.ibm.com/support/entry/portal/docdisplay?Indocid=">http://www-947.ibm.com/support/entry/portal/docdisplay?Indocid=</a></li> <li>6. Rerun the test. See “Diagnostic tools overview” on page 84.</li> <li>7. Replace the CD or DVD drive. Refer to your BladeCenter documentation for information about replacing the drive.</li> <li>8. If the failure remains, collect the data from the DSA event log and send it to IBM Service. For information about contacting and sending data to IBM Service, see “Hardware service and support” on page 205.</li> </ol>
215-904-xxx	Failed the optical drive self test due to a possible read error.	<ol style="list-style-type: none"> <li>1. Insert a new CD or DVD into the optical drive and wait for 15 seconds for the media to be recognized; then, rerun the test. See “Diagnostic tools overview” on page 84.</li> <li>2. Make sure that the cable for the optical drive is securely connected at both ends of the cable. See your BladeCenter documentation for information about the optical drive (media tray).</li> <li>3. Make sure that the cable for the optical drive is not damaged; then, replace the cable if damage is present. See your BladeCenter documentation for information about replacing the optical drive (media tray).</li> <li>4. Rerun the test. See “Diagnostic tools overview” on page 84.</li> <li>5. For additional troubleshooting information, go to <a href="http://www-947.ibm.com/support/entry/portal/docdisplay?Indocid=">http://www-947.ibm.com/support/entry/portal/docdisplay?Indocid=</a></li> <li>6. Rerun the test. See “Diagnostic tools overview” on page 84.</li> <li>7. Replace the CD or DVD drive. See your BladeCenter documentation for information about replacing the optical drive (media tray).</li> <li>8. If the failure remains, collect the data from the DSA event log and send it to IBM Service. For information about contacting and sending data to IBM Service, see “Hardware service and support” on page 205.</li> </ol>



---

## Storage drive self tests

Use this information to diagnose and resolve storage drive self test problems for the blade server.

Follow the suggested actions in the order in which they are listed in the Action column until the problem is solved.

<ul style="list-style-type: none"><li>• See Chapter 3 “Parts listing” on page 33 to determine which components are consumable, structural, or CRU parts.</li><li>• If an action step is preceded by “(trained technician only),” that step must be performed only by a trained technician.</li></ul>		
Error code	Description	Action
217-000-000	Passed the storage drive self test.	N/A
217-900-xxx	Failed the storage drive self test.	<ol style="list-style-type: none"><li>1. Make sure that the storage drive is securely connected in the storage drive connector, then; reseal the storage drive.</li><li>2. Rerun the test.</li><li>3. Make sure that the system BIOS firmware is at the latest level, upgrade if necessary; then, rerun the test. The BIOS firmware level can be found in the DSA Diagnostic Event Log within the Firmware/VPD section for this component. The latest level firmware for this component can be found on the IBM support Web site at <a href="http://www.ibm.com/support/docview.wss?uid=psg1MIGR-63017">http://www.ibm.com/support/docview.wss?uid=psg1MIGR-63017</a>.</li><li>4. Rerun the test.</li><li>5. If the component failure remains, refer to Chapter 4 “Removing and replacing blade server components” on page 39 to replace the failed component.</li></ol>
217-800-xxx	The storage drive self test was terminated by the user.	N/A

---

## Tape alert flags

Use this information to diagnose and resolve tape alert flags for the blade server.

Tape alert flags are numbered 1 through 64 and indicate a specific media-changer error condition. Each tape alert is returned as an individual log parameter, and its state is indicated in bit 0 of the 1-byte Parameter Value field of the log parameter. When this bit is set to 1, the alert is active.

Each tape alert flag has one of the following severity levels:

- C - Critical
- W - Warning
- I - Information

Different tape drives support some or all of the following flags in the tape alert log:

**Flag 2: Library Hardware B (W)** This flag is set when an unrecoverable mechanical error occurs.

**Flag 4: Library Hardware D (C)** This flag is set when the tape drive fails the power-on self-test or a mechanical error occurs that requires a power cycle to recover. This flag is internally cleared when the drive is powered-off.

**Flag 13: Library Pick Retry (W)** This flag is set when a high retry count threshold is passed during an operation to pick a cartridge from a slot before the operation succeeds. This flag is internally cleared when another pick operation is attempted.

**Flag 14: Library Place Retry (W)** This flag is set when a high retry count threshold is passed during an operation to place a cartridge back into a slot before the operation succeeds. This flag is internally cleared when another place operation is attempted.

**Flag 15: Library Load Retry (W)** This flag is set when a high retry count threshold is passed during an operation to load a cartridge into a drive before the operation succeeds. This flag is internally cleared when another load operation is attempted. Note that if the load operation fails because of a media or drive problem, the drive sets the applicable tape alert flags.

**Flag 16: Library Door (C)** This flag is set when media move operations cannot be performed because a door is open. This flag is internally cleared when the door is closed.

**Flag 23: Library Scan Retry (W)** This flag is set when a high retry count threshold is passed during an operation to scan the bar code on a cartridge before the operation succeeds. This flag is internally cleared when another bar code scanning operation is attempted.

---

## Recovering from a UEFI update failure

Use this information to recover from a UEFI update failure in the blade server.

**Important:** Some cluster solutions require specific code levels or coordinated code updates. If the device is part of a cluster solution, verify that the latest level of code is supported for the cluster solution before you update the code.

If the server firmware has become corrupted, such as from a power failure during an update, you can recover the server firmware in one of four ways:

- **In-band manual recovery method** (See “In-band manual recovery method” on page 192.)
- **Out-of-band manual recovery method** (See “Out-of-band manual recovery method” on page 193.)
- **In-band automated boot recovery method** (See “In-band automated boot recovery method” on page 195.)
- **Out-of-band automated boot recovery method** (See “Out-of-band automated boot recovery method” on page 195.)

### In-band manual recovery method

To recover the server firmware and restore the server operation to the primary bank, complete the following steps:

- Step 1. Download the blade server UEFI firmware update from the World Wide Web (see “Updating firmware and device drivers” on page 23).
- Step 2. Turn off the server (see “Turning off the blade server” on page 7).
- Step 3. Remove the blade server from the BladeCenter unit (see “Removing the blade server from the BladeCenter unit” on page 41).
- Step 4. Remove the server cover. See “Removing the blade server cover” on page 43 for more information.
- Step 5. Locate the UEFI boot block recovery switch (SW1-5) on the system board (see “System-board switch” on page 8).
- Step 6. Use your finger to move switch SW1-5 to the ON position.

- Step 7. Replace the cover and reinstall the blade server in the BladeCenter unit, making sure that the media tray is selected by the relevant blade server. See “Installing the blade server cover” on page 44 and “Installing the blade server in a BladeCenter unit” on page 41.
- Step 8. Restart the blade server (see “Turning on the blade server” on page 6). The system begins the power-on self-test (POST).
- Step 9. Boot the server to an operating system that is supported by the firmware update package that you downloaded.
- Step 10. Perform the firmware update by following the instructions that are in the firmware update package readme file.
- Step 11. Copy the downloaded firmware update package into a directory.
- Step 12. From a command line, type *filename -s*, where *filename* is the name of the executable file that you downloaded with the firmware update package.
- Step 13. Reboot the server and verify that it completes POST (see “Turning off the blade server” on page 7).
- Step 14. Turn off the server (see “Turning off the blade server” on page 7).
- Step 15. Remove the blade server from the BladeCenter unit (see “Removing the blade server from the BladeCenter unit” on page 41).
- Step 16. Remove the server cover. See “Removing the blade server cover” on page 43.
- Step 17. Move the UEFI boot block recovery switch (SW1-5) to the OFF position (see “System-board switch” on page 8).
- Step 18. Replace the cover and reinstall the blade server in the BladeCenter unit, making sure that the media tray is selected by the relevant blade server. See “Installing the blade server cover” on page 44 and “Installing the blade server in a BladeCenter unit” on page 41.
- Step 19. Restart the blade server (see “Turning off the blade server” on page 7 and “Turning on the blade server” on page 6). The system begins the power-on self-test (POST). If this does not recover the primary bank continue with the following steps.
- Step 20. Remove the blade server from the BladeCenter unit (see “Removing the blade server from the BladeCenter unit” on page 41).
- Step 21. Remove the server cover. See “Removing the blade server cover” on page 43.
- Step 22. Reset the CMOS by removing the battery (see “Removing the battery” on page 51).
- Step 23. Leave the battery out of the server for 5 minutes.
- Step 24. Reinstall the CMOS battery (see “Installing the battery” on page 51).
- Step 25. Replace the cover and reinstall the blade server in the BladeCenter unit, making sure that the media tray is selected by the relevant blade server. See “Installing the blade server cover” on page 44 and “Installing the blade server in a BladeCenter unit” on page 41.
- Step 26. Restart the blade server (see “Turning off the blade server” on page 7 and “Turning on the blade server” on page 6).

The system begins the power-on self-test (POST).

## Out-of-band manual recovery method

To recover the server firmware and restore the server operation to the primary bank, complete the following steps:

- Step 1. Download the blade server UEFI firmware update from the World Wide Web (see “Updating firmware and device drivers” on page 23).
- Step 2. Turn off the server (see “Turning off the blade server” on page 7).

- Step 3. Remove the blade server from the BladeCenter unit (see “Removing the blade server from the BladeCenter unit” on page 41).
- Step 4. Remove the server cover. See “Removing the blade server cover” on page 43 for more information.
- Step 5. Locate the UEFI boot block recovery switch (SW1-5) on the system board (see “System-board switch” on page 8).
- Step 6. Use your finger to move switch SW1-5 to the ON position.
- Step 7. Replace the cover and reinstall the blade server in the BladeCenter unit, making sure that the media tray is selected by the relevant blade server. See “Installing the blade server cover” on page 44 and “Installing the blade server in a BladeCenter unit” on page 41.
- Step 8. Restart the blade server (see “Turning on the blade server” on page 6). The system begins the power-on self-test (POST).
- Step 9. Boot the server to the operating system or the F1 UEFI configuration menu.
- Step 10. Log into the Advanced Management's web interface.
- Step 11. After you log in, select **MM Control -> Network Protocol** and ensure that TFTP is enabled on the management module. The default setting is disable.
- Step 12. Select **Blade Tasks -> Firmware update** and select the blade server you want to recover.
- Step 13. Use the browse button to point to the UEFI update file.
- Step 14. Click the **Update** button to update the UEFI firmware.
- Step 15. Reboot the server and verify that it completes POST (see “Turning off the blade server” on page 7).
- Step 16. Turn off the server (see “Turning off the blade server” on page 7).
- Step 17. Remove the blade server from the BladeCenter unit (see “Removing the blade server from the BladeCenter unit” on page 41).
- Step 18. Remove the server cover. See “Removing the blade server cover” on page 43.
- Step 19. Move the UEFI boot block recovery switch (SW1-5) to the OFF position (see “System-board switch” on page 8).
- Step 20. Replace the cover and reinstall the blade server in the BladeCenter unit, making sure that the media tray is selected by the relevant blade server. See “Installing the blade server cover” on page 44 and “Installing the blade server in a BladeCenter unit” on page 41.
- Step 21. Restart the blade server (see “Turning off the blade server” on page 7 and “Turning on the blade server” on page 6). The system begins the power-on self-test (POST). If this does not recover the primary bank continue with the following steps.
- Step 22. Remove the blade server from the BladeCenter unit (see “Removing the blade server from the BladeCenter unit” on page 41).
- Step 23. Remove the server cover. See “Removing the blade server cover” on page 43.
- Step 24. Reset the CMOS by removing the battery (see “Removing the battery” on page 51).
- Step 25. Leave the battery out of the server for 5 minutes.
- Step 26. Reinstall the CMOS battery (see “Installing the battery” on page 51).
- Step 27. Replace the cover and reinstall the blade server in the BladeCenter unit, making sure that the media tray is selected by the relevant blade server. See “Installing the blade server cover” on page 44 and “Installing the blade server in a BladeCenter unit” on page 41.
- Step 28. Restart the blade server (see “Turning off the blade server” on page 7 and “Turning on the blade server” on page 6).

The system begins the power-on self-test (POST).

## In-band automated boot recovery method

To download the server UEFI firmware update package from the World Wide Web, complete the following steps.

**Note:** Use this method if the SYS BOARD LED on the light path diagnostics panel is lit and there is an AMM event log entry or Booting Backup Image is displayed on the firmware splash screen; otherwise, use the in-band manual recovery method.

- Step 1. Download the blade server UEFI firmware update from the World Wide Web (see “Updating firmware and device drivers” on page 23).
- Step 2. Boot the server to an operating system that is supported by the firmware update package that you downloaded (see “Turning on the blade server” on page 6).
- Step 3. Perform the firmware update by following the instructions that are in the firmware update package readme file.
- Step 4. Restart the server (see “Turning off the blade server” on page 7 and “Turning on the blade server” on page 6).
- Step 5. At the firmware splash screen, press F3 when prompted to restore to the primary bank. The server boots from the primary bank.

## Out-of-band automated boot recovery method

To download the server UEFI firmware update package from the World Wide Web, complete the following steps.

**Note:** Use this method if the SYS BRD LED on the light path diagnostics panel is lit and there is an AMM event log entry or Booting Backup Image is displayed on the firmware splash screen; otherwise, use the out-of-band manual recovery method.

- Step 1. Download the blade server UEFI firmware update for your blade server (see “Updating firmware and device drivers” on page 23).
- Step 2. Log into the Advanced Management Module's web interface.
- Step 3. After you log in, select **MM Control** ® **Network Protocols** and ensure that TFTP is enabled on the management module. It is disabled by default.
- Step 4. Select **Blade Tasks** ® **Firmware update** and select the blade server to recover.
- Step 5. Use the browse button to point to the UEFI update file.
- Step 6. Click the **Update** button to update the UEFI firmware.
- Step 7. Restart the server (see “Turning off the blade server” on page 7 and “Turning on the blade server” on page 6).
- Step 8. At the firmware splash screen, press F3 when prompted to restore to the primary bank. The server boots from the primary bank.

---

## Automated boot recovery (ABR)

While the server is starting, if the integrated management module detects problems with the server firmware in the primary bank, the server automatically switches to the backup firmware bank and gives you the opportunity to recover the firmware in the primary bank. For instructions for recovering the UEFI firmware, see “Recovering from a UEFI update failure” on page 192. After you have recovered the firmware in the primary bank, complete the following steps:

- Step 1. Restart the server.

Step 2. When the prompt Press F3 to restore to primary is displayed, press F3 to start the server from the primary bank.

---

## Nx boot failure

Configuration changes, such as added devices or adapter firmware updates, and firmware or application code problems can cause the server to fail POST (the power-on self-test). If this occurs, the server responds in either of the following ways:

- The server restarts automatically and attempts POST again.
- The server hangs, and you must manually restart the server for the server to attempt POST again.

After a specified number of consecutive attempts (automatic or manual), the Nx boot failure feature causes the server to revert to the default UEFI configuration and start the Setup utility so that you can make the necessary corrections to the configuration and restart the server. If the server is unable to successfully complete POST with the default configuration, there might be a problem with the system board.

To specify the number of consecutive restart attempts that will trigger the Nx boot failure feature, complete the following steps:

Step 1. In the Setup utility, click **System Settings → Recovery → POST Attempts → POST Attempts Limit**.

Step 2. The available options are 3, 6, 9, and 255 (disable Nx boot failure). Select your option.

---

## Solving SAS hard disk drive problems

Use this information to diagnose and resolve SAS hard disk drive issues.

For any SAS error message, one or more of the following devices might be causing the problem:

- A failing SAS device (adapter, drive, or controller)
- An incorrect SAS configuration

For any SAS error message, make sure that the SAS devices are configured correctly.

---

## Solving shared BladeCenter resource problems

Use this information to diagnose and resolve shared BladeCenter resource issues.

Problems with BladeCenter shared resources might appear to be in the blade server. The following sections provide procedures to help you isolate blade server problems from shared BladeCenter resource problems. If the problem is thought to be with a shared resource, see the *Problem Determination and Service Guide* for your BladeCenter unit and other BladeCenter component documentation for additional information. If the problem cannot be solved, see “Solving undetermined problems” on page 200.

To check the general function of shared BladeCenter resources, complete the following tasks:

- Make sure that:
  - The BladeCenter unit has the required power modules and is connected to a working power source.
  - Power management has been correctly set for your BladeCenter unit configuration.
- Determine whether the problem is being experienced with more than one blade server. Perform a test of the function on a known-good blade server.
- Try the blade server in a different blade server bay.

- Try a known-good blade server in the blade server bay.

## Keyboard or mouse problems

Use this information to diagnose and resolve keyboard and mouse issues.

To check for keyboard or mouse problems, complete the following steps until the problem is solved:

Step 1. Make sure that:

- Both the blade server and the monitor are turned on.
- The keyboard/video/mouse select button LED on the front of the blade server is lit, indicating that the blade server is connected to the shared keyboard and mouse.
- The keyboard or mouse cable is securely connected to the active BladeCenter Advanced Management Module.
- The keyboard or mouse works with another blade server.

Step 2. Check for correct Advanced-Management-Module operation (see the documentation for your BladeCenter unit).

**Note:** Some BladeCenter unit types have several management-module components that might have to be tested or replaced (see the *Installation Guide* for your Advanced Management Module for more information).

Step 3. Replace the keyboard or mouse.

Step 4. Replace the Advanced Management Module (see the documentation for your BladeCenter unit).

If these steps do not solve the problem, it is likely a problem with the blade server. See “Keyboard or mouse problems” on page 152.

## Media tray problems

Use this information to diagnose and resolve media tray issues for the blade server.

To check for problems with the media tray (removable media drives and USB ports), complete the following steps until the problem is solved:

Step 1. Make sure that:

- The media-tray select button LED on the front of the blade server is lit, indicating that the blade server is connected to the shared media tray.
- The media tray devices work with another blade server.

Step 2. Determine whether the problem affects more than one media tray component:

- USB ports
- Diskette drive
- CD or DVD drive

Step 3. For problems that affect only a USB port:

- a. Make sure that the USB device is operational. If you are using a USB hub, make sure that the hub is operating correctly and that any software that the hub requires is installed. Connect the USB device directly to the USB port, bypassing the hub, to check its operation.
- b. Reseat the following components:
  1. USB device cable
  2. Media tray cable (if applicable)
  3. Media tray

- c. Replace the following components one at a time, in the order shown, restarting the blade server each time:
  - 1. USB cable (if applicable)
  - 2. Media tray cable (if applicable)
  - 3. Media tray
- d. Continue with “Media tray problems” on page 197.

Step 4. For problems that affect only the diskette drive, make sure that:

- a. The diskette is inserted correctly in the drive.
- b. The diskette is good and not damaged; the drive LED flashes once per second when the diskette is inserted. (Try another diskette if you have one.)
- c. The diskette contains the necessary files to start the blade server.
- d. The software program is working correctly.
- e. The distance between monitors and diskette drives is at least 76 mm (3 in.).

Step 5. For problems that affect only the CD or DVD drive, make sure that:

- a. The CD or DVD is inserted correctly in the drive. If necessary, insert the end of a straightened paper clip into the manual tray-release opening to eject the CD or DVD. The drive LED light flashes once per second when the CD or DVD is inserted.
- b. The CD or DVD is clean and not damaged. (Try another CD or DVD if you have one.)
- c. The software program is working properly.

Step 6. For problems that affect one or more of the removable media drives:

- a. Reseat the following components:
  - 1. Removable-media drive cable (if applicable)
  - 2. Removable-media drive
  - 3. Media tray cable (if applicable)
  - 4. Media tray
- b. Replace the following components one at a time, in the order shown, restarting the blade server each time:
  - 1. Removable-media drive cable (if applicable)
  - 2. Media tray cable (if applicable)
  - 3. Removable-media drive
  - 4. Media tray

Step 7. Check for correct Advanced-Management-Module operation (see the documentation for your BladeCenter unit).

**Note:** Some BladeCenter unit types have several management-module components that might have to be tested or replaced (see the *Installation Guide* for your Advanced Management Module for more information).

Step 8. Replace the Advanced Management Module (see the documentation for your BladeCenter unit).

If these steps do not solve the problem, it is likely a problem with the blade server. See “Removable-media drive problems” on page 161 or “Universal Serial Bus (USB) port problems” on page 164.

## Network connection problems

Use this information to diagnose and resolve network connection issues with the blade server.



To check for network connection problems, complete the following steps until the problem is solved:

Step 1. Make sure that:

- The network cables are securely connected to the I/O module.
- Power configuration of the BladeCenter unit supports the I/O-module configuration.
- Installation of the I/O-module type is supported by the BladeCenter unit and blade server hardware.
- The I/O modules for the network interface that is being used are installed in the correct BladeCenter I/O-module bays and are configured and operating correctly.
- The settings in the I/O module are correct for the blade server (settings in the I/O module are specific to each blade server).

Step 2. Check for correct I/O-module operation; troubleshoot and replace the I/O module as indicated in the documentation for the I/O module.

Step 3. Check for correct management-module operation (see the documentation for your BladeCenter unit).

**Note:** Some BladeCenter unit types have several management-module components that might have to be tested or replaced (see the *Installation Guide* for your Advanced Management Module for more information).

Step 4. Replace the Advanced Management Module (see the documentation for your BladeCenter unit).

If these steps do not solve the problem, it is likely a problem with the blade server. See “Network connection problems” on page 155.

## Power problems

Use this information to diagnose and resolve power issues with the blade server.

To check for power problems, make sure that:

- The LEDs on all the BladeCenter power modules are lit.
- Power is being supplied to the BladeCenter unit.
- The BladeCenter unit support installation of the blade server type.
- The BladeCenter unit has the correct power configuration to operate the blade server bay where the blade server is installed (see the documentation for your BladeCenter unit).
- The BladeCenter unit power-management configuration and status support blade server operation (see the *Advanced Management Module User's Guide* or the *Management Module Command-Line Interface Reference Guide* for information).
- Local power control for the blade server is correctly set (see the *Management Module User's Guide* or the *Advanced Management Module Command-Line Interface Reference Guide* for information).
- The power LED on the blade server flashes slowly before you press the power button.

**Note:** While the service processor in the blade server is initializing and synchronizing with the management module, the power LED flashes rapidly, and the power button on the blade server does not respond. This process can take approximately two minutes after the blade server has been installed.

- The BladeCenter unit blowers are correctly installed and operational.

If these procedures do not solve the problem, it is likely a problem with the blade server. See “Power error messages” on page 156 and “Power problems” on page 159.

## Video problems

Use this information to diagnose and resolve video issues .

To check for video problems, complete the following steps until the problem is solved:

Step 1. Make sure that:

- Both the blade server and the monitor are turned on, and the monitor brightness and contrast controls are correctly adjusted.
- The keyboard/video/mouse select button LED on the front of the blade server is lit, indicating that the blade server is connected to the shared BladeCenter monitor.
- The video cable is securely connected to the BladeCenter Advanced Management Module. Non-IBM monitor cables might cause unpredictable problems.
- The monitor works with another blade server.
- Some IBM monitors have their own self-tests. If you suspect a problem with the monitor, see the information that comes with the monitor for instructions for adjusting and testing the monitor. If the monitor self-tests show that the monitor is working correctly, consider the location of the monitor. Magnetic fields around other devices (such as transformers, appliances, fluorescent lights, and other monitors) can cause screen jitter or wavy, unreadable, rolling, or distorted screen images. If this happens, turn off the monitor.

**Attention:** Moving a color monitor while it is turned on might cause screen discoloration.

Move the device and the monitor at least 305 mm (12 in.) apart. Turn on the monitor. To prevent diskette drive read/write errors, make sure that the distance between the monitor and any diskette drive is at least 76 mm (3 in.).

Step 2. Check for correct Advanced-Management-Module operation (see the documentation for your BladeCenter unit).

**Note:** Some BladeCenter unit types have several management-module components that might have to be tested or replaced (see the *Installation Guide* for your Advanced Management Module for more information).

Step 3. Replace the monitor cable, if applicable.

Step 4. Replace the monitor.

Step 5. Replace the Advanced Management Module (see the documentation for your BladeCenter unit).

If these steps do not solve the problem, it is likely a problem with the blade server. See “Monitor or video problems” on page 154.

---

## Solving undetermined problems

Use this information to diagnose and resolve undetermined issues with the blade server.

**Notes:** When you are diagnosing a problem in the blade server, you must determine whether the problem is in the blade server or in the BladeCenter unit.

- If all of the blade servers have the same symptom, the problem is probably in the BladeCenter unit. For more information, see the *Hardware Maintenance Manual and Troubleshooting Guide* or *Problem Determination and Service Guide* for your BladeCenter unit.
- If the BladeCenter unit contains more than one blade server and only one of the blade servers has the problem, troubleshoot the blade server that has the problem.

If the diagnostic tests did not diagnose the failure or if the blade server is inoperative, use the information in this section.

If you suspect that a software problem is causing failures (continuous or intermittent), see “Software problems” on page 163.

Damaged data in CMOS memory or damaged UEFI code can cause undetermined problems. To reset the CMOS data, remove and replace the battery to override the power-on password and clear the CMOS memory; see “Removing the battery” on page 51. If you suspect that the UEFI code is damaged, see “Recovering from a UEFI update failure” on page 192.

Check the LEDs on all the power supplies of the BladeCenter unit in which the blade server is installed. If the LEDs indicate that the power supplies are working correctly and reseating the blade server does not correct the problem, complete the following steps:

1. Make sure that the control panel connector is correctly seated on the system board (see “Blade server connectors” on page 7 for the location of the connector).
2. If no LEDs on the control panel are working, replace the bezel assembly; then, try to turn on the blade server from the Advanced Management Module (see the documentation for the BladeCenter unit and Advanced Management Module for more information).
3. Turn off the blade server.
4. Remove the blade server from the BladeCenter unit and remove the cover.
5. Remove or disconnect the following devices, one at a time, until you find the failure. Reinstall, turn on, and reconfigure the blade server each time.
  - I/O expansion card.
  - Storage drives.
  - Memory modules. The minimum configuration requirement is 2 GB per microprocessor installed in the server.

The following minimum configuration is required for the blade server to start:

- System board
  - One microprocessor
  - One 2 GB DIMM
  - A functioning BladeCenter unit
6. Install and turn on the blade server. If the problem remains, suspect the following components in the following order:
    - a. DIMM
    - b. System board
    - c. Microprocessor

If the problem is solved when you remove an I/O expansion card from the blade server but the problem recurs when you reinstall the same card, suspect the I/O expansion card; if the problem recurs when you replace the card with a different one, suspect the system board.

If you suspect a networking problem and the blade server passes all the system tests, suspect a network cabling problem that is external to the system.

---

## Problem determination tips

Use these tips to determine problems with the blade server.

Because of the variety of hardware and software combinations that you can encounter, use the following information to assist you in problem determination. If possible, have this information available when you request assistance from IBM.

- Machine type and model
- Microprocessor and hard disk drive upgrades
- Failure symptoms
  - Does the blade server fail the diagnostic tests?
  - What occurs? When? Where?

- Does the failure occur on a single server or on multiple servers?
- Is the failure repeatable?
- Has this configuration ever worked?
- What changes, if any, were made before the configuration failed?
- Is this the original reported failure?
- Diagnostic program type and version level
- Hardware configuration (print screen of the system summary)
- UEFI code level
- Operating-system type and version level

You can solve some problems by comparing the configuration and software setups between working and nonworking servers. When you compare servers to each other for diagnostic purposes, consider them identical only if all the following factors are exactly the same in all the blade servers:

- Machine type and model
- UEFI level
- Adapters and attachments, in the same locations
- Address jumpers, terminators, and cabling
- Software versions and levels
- Diagnostic program type and version level
- Configuration option settings
- Operating-system control-file setup

---

## Appendix A. Getting help and technical assistance

If you need help, service, or technical assistance or just want more information about IBM products, you will find a wide variety of sources available from IBM to assist you.

Use this information to obtain additional information about IBM and IBM products, determine what to do if you experience a problem with your IBM system or optional device, and determine whom to call for service, if it is necessary.

---

### Before you call

Before you call, make sure that you have taken these steps to try to solve the problem yourself.

If you believe that you require IBM to perform warranty service on your IBM product, the IBM service technicians will be able to assist you more efficiently if you prepare before you call.

- Check all cables to make sure that they are connected.
- Check the power switches to make sure that the system and any optional devices are turned on.
- Check for updated software, firmware, and operating-system device drivers for your IBM product. The IBM Warranty terms and conditions state that you, the owner of the IBM product, are responsible for maintaining and updating all software and firmware for the product (unless it is covered by an additional maintenance contract). Your IBM service technician will request that you upgrade your software and firmware if the problem has a documented solution within a software upgrade.
- If you have installed new hardware or software in your environment, check <http://www.ibm.com/systems/info/x86servers/serverproven/compat/us> to make sure that the hardware and software is supported by your IBM product.
- Go to <http://www.ibm.com/supportportal> to check for information to help you solve the problem.
- Gather the following information to provide to IBM Support. This data will help IBM Support quickly provide a solution to your problem and ensure that you receive the level of service for which you might have contracted.
  - Hardware and Software Maintenance agreement contract numbers, if applicable
  - Machine type number (IBM 4-digit machine identifier)
  - Model number
  - Serial number
  - Current system UEFI and firmware levels
  - Other pertinent information such as error messages and logs
- Go to [http://www.ibm.com/support/entry/portal/Open\\_service\\_request](http://www.ibm.com/support/entry/portal/Open_service_request) to submit an Electronic Service Request. Submitting an Electronic Service Request will start the process of determining a solution to your problem by making the pertinent information available to IBM Support quickly and efficiently. IBM service technicians can start working on your solution as soon as you have completed and submitted an Electronic Service Request.

You can solve many problems without outside assistance by following the troubleshooting procedures that IBM provides in the online help or in the documentation that is provided with your IBM product. The documentation that comes with IBM systems also describes the diagnostic tests that you can perform. Most systems, operating systems, and programs come with documentation that contains troubleshooting procedures and explanations of error messages and error codes. If you suspect a software problem, see the documentation for the operating system or program.

---

## Using the documentation

Information about your IBM system and preinstalled software, if any, or optional device is available in the documentation that comes with the product. That documentation can include printed documents, online documents, readme files, and help files.

See the troubleshooting information in your system documentation for instructions for using the diagnostic programs. The troubleshooting information or the diagnostic programs might tell you that you need additional or updated device drivers or other software. IBM maintains pages on the World Wide Web where you can get the latest technical information and download device drivers and updates. To access these pages, go to <http://www.ibm.com/supportportal>.

---

## Getting help and information from the World Wide Web

Up-to-date information about IBM products and support is available on the World Wide Web.

On the World Wide Web, up-to-date information about IBM systems, optional devices, services, and support is available at <http://www.ibm.com/supportportal>. IBM System x information is at <http://www.ibm.com/systems/x>. IBM BladeCenter information is at <http://www.ibm.com/systems/bladecenter>. IBM IntelliStation information is at <http://www.ibm.com/systems/intellistation>.

---

## How to send DSA data to IBM

Use the IBM Enhanced Customer Data Repository to send diagnostic data to IBM.

Before you send diagnostic data to IBM, read the terms of use at <http://www.ibm.com/de/support/ecurep/terms.html>.

You can use any of the following methods to send diagnostic data to IBM:

- **Standard upload:** [http://www.ibm.com/de/support/ecurep/send\\_http.html](http://www.ibm.com/de/support/ecurep/send_http.html)
- **Standard upload with the system serial number:** [http://www.ecurep.ibm.com/app/upload\\_hw](http://www.ecurep.ibm.com/app/upload_hw)
- **Secure upload:** [http://www.ibm.com/de/support/ecurep/send\\_http.html#secure](http://www.ibm.com/de/support/ecurep/send_http.html#secure)
- **Secure upload with the system serial number:** [https://www.ecurep.ibm.com/app/upload\\_hw](https://www.ecurep.ibm.com/app/upload_hw)

---

## Creating a personalized support web page

You can create a personalized support web page by identifying IBM products that are of interest to you.

To create a personalized support web page, go to <http://www.ibm.com/support/mynotifications>. From this personalized page, you can subscribe to weekly email notifications about new technical documents, search for information and downloads, and access various administrative services.

---

## Software service and support

Through IBM Support Line, you can get telephone assistance, for a fee, with usage, configuration, and software problems with your IBM products.

For information about which products are supported by Support Line in your country or region, see <http://www.ibm.com/services/supline/products>.

For more information about Support Line and other IBM services, see <http://www.ibm.com/services> or see <http://www.ibm.com/planetwide> for support telephone numbers. In the U.S. and Canada, call 1-800-IBM-SERV (1-800-426-7378).

---

## Hardware service and support

You can receive hardware service through your IBM reseller or IBM Services.

To locate a reseller authorized by IBM to provide warranty service, go to <http://www.ibm.com/partnerworld> and click **Business Partner Locator**. For IBM support telephone numbers, see <http://www.ibm.com/planetwide>. In the U.S. and Canada, call 1-800-IBM-SERV (1-800-426-7378).

In the U.S. and Canada, hardware service and support is available 24 hours a day, 7 days a week. In the U.K., these services are available Monday through Friday, from 9 a.m. to 6 p.m.

---

## IBM Taiwan product service

Use this information to contact IBM Taiwan product service.

台灣 IBM 產品服務聯絡方式：  
台灣國際商業機器股份有限公司  
台北市松仁路 7 號 3 樓  
電話：0800-016-888

IBM Taiwan product service contact information:

IBM Taiwan Corporation  
3F, No 7, Song Ren Rd.  
Taipei, Taiwan  
Telephone: 0800-016-888





---

## Appendix B. Notices

This information was developed for products and services offered in the U.S.A.

IBM may not offer the products, services, or features discussed in this document in other countries. Consult your local IBM representative for information on the products and services currently available in your area. Any reference to an IBM product, program, or service is not intended to state or imply that only that IBM product, program, or service may be used. Any functionally equivalent product, program, or service that does not infringe any IBM intellectual property right may be used instead. However, it is the user's responsibility to evaluate and verify the operation of any non-IBM product, program, or service.

IBM may have patents or pending patent applications covering subject matter described in this document. The furnishing of this document does not give you any license to these patents. You can send license inquiries, in writing, to:

*IBM Director of Licensing  
IBM Corporation  
North Castle Drive  
Armonk, NY 10504-1785  
U.S.A.*

INTERNATIONAL BUSINESS MACHINES CORPORATION PROVIDES THIS PUBLICATION "AS IS" WITHOUT WARRANTY OF ANY KIND, EITHER EXPRESS OR IMPLIED, INCLUDING, BUT NOT LIMITED TO, THE IMPLIED WARRANTIES OF NON-INFRINGEMENT, MERCHANTABILITY OR FITNESS FOR A PARTICULAR PURPOSE. Some states do not allow disclaimer of express or implied warranties in certain transactions, therefore, this statement may not apply to you.

This information could include technical inaccuracies or typographical errors. Changes are periodically made to the information herein; these changes will be incorporated in new editions of the publication. IBM may make improvements and/or changes in the product(s) and/or the program(s) described in this publication at any time without notice.

Any references in this information to non-IBM websites are provided for convenience only and do not in any manner serve as an endorsement of those websites. The materials at those websites are not part of the materials for this IBM product, and use of those websites is at your own risk.

IBM may use or distribute any of the information you supply in any way it believes appropriate without incurring any obligation to you.

---

## Trademarks

IBM, the IBM logo, and [ibm.com](http://www.ibm.com) are trademarks of International Business Machines Corp., registered in many jurisdictions worldwide. Other product and service names might be trademarks of IBM or other companies.

A current list of IBM trademarks is available on the web at <http://www.ibm.com/legal/us/en/copytrade.shtml>.

Adobe and PostScript are either registered trademarks or trademarks of Adobe Systems Incorporated in the United States and/or other countries.

Cell Broadband Engine is a trademark of Sony Computer Entertainment, Inc., in the United States, other countries, or both and is used under license therefrom.

Intel, Intel Xeon, Itanium, and Pentium are trademarks or registered trademarks of Intel Corporation or its subsidiaries in the United States and other countries.

Java and all Java-based trademarks and logos are trademarks or registered trademarks of Oracle and/or its affiliates.

Linux is a registered trademark of Linus Torvalds in the United States, other countries, or both.

Microsoft, Windows, and Windows NT are trademarks of Microsoft Corporation in the United States, other countries, or both.

UNIX is a registered trademark of The Open Group in the United States and other countries.

---

## Important notes

Processor speed indicates the internal clock speed of the microprocessor; other factors also affect application performance.

CD or DVD drive speed is the variable read rate. Actual speeds vary and are often less than the possible maximum.

When referring to processor storage, real and virtual storage, or channel volume, KB stands for 1024 bytes, MB stands for 1,048,576 bytes, and GB stands for 1,073,741,824 bytes.

When referring to hard disk drive capacity or communications volume, MB stands for 1,000,000 bytes, and GB stands for 1,000,000,000 bytes. Total user-accessible capacity can vary depending on operating environments.

Maximum internal hard disk drive capacities assume the replacement of any standard hard disk drives and population of all hard disk drive bays with the largest currently supported drives that are available from IBM.

Maximum memory might require replacement of the standard memory with an optional memory module.

Each solid-state memory cell has an intrinsic, finite number of write cycles that the cell can incur. Therefore, a solid-state device has a maximum number of write cycles that it can be subjected to, expressed as total bytes written (TBW). A device that has exceeded this limit might fail to respond to system-generated commands or might be incapable of being written to. IBM is not responsible for replacement of a device that has exceeded its maximum guaranteed number of program/erase cycles, as documented in the Official Published Specifications for the device.

IBM makes no representation or warranties regarding non-IBM products and services that are ServerProven, including but not limited to the implied warranties of merchantability and fitness for a particular purpose. These products are offered and warranted solely by third parties.

IBM makes no representations or warranties with respect to non-IBM products. Support (if any) for the non-IBM products is provided by the third party, not IBM.

Some software might differ from its retail version (if available) and might not include user manuals or all program functionality.

---

## Particulate contamination

**Attention:** Airborne particulates (including metal flakes or particles) and reactive gases acting alone or in combination with other environmental factors such as humidity or temperature might pose a risk to the device that is described in this document.

Risks that are posed by the presence of excessive particulate levels or concentrations of harmful gases include damage that might cause the device to malfunction or cease functioning altogether. This specification sets forth limits for particulates and gases that are intended to avoid such damage. The limits must not be viewed or used as definitive limits, because numerous other factors, such as temperature or moisture content of the air, can influence the impact of particulates or environmental corrosives and gaseous contaminant transfer. In the absence of specific limits that are set forth in this document, you must implement practices that maintain particulate and gas levels that are consistent with the protection of human health and safety. If IBM determines that the levels of particulates or gases in your environment have caused damage to the device, IBM may condition provision of repair or replacement of devices or parts on implementation of appropriate remedial measures to mitigate such environmental contamination. Implementation of such remedial measures is a customer responsibility.

Table 10. Limits for particulates and gases

Contaminant	Limits
Particulate	<ul style="list-style-type: none"> <li>The room air must be continuously filtered with 40% atmospheric dust spot efficiency (MERV 9) according to ASHRAE Standard 52.2<sup>1</sup>.</li> <li>Air that enters a data center must be filtered to 99.97% efficiency or greater, using high-efficiency particulate air (HEPA) filters that meet MIL-STD-282.</li> <li>The deliquescent relative humidity of the particulate contamination must be more than 60%<sup>2</sup>.</li> <li>The room must be free of conductive contamination such as zinc whiskers.</li> </ul>
Gaseous	<ul style="list-style-type: none"> <li>Copper: Class G1 as per ANSI/ISA 71.04-1985<sup>3</sup></li> <li>Silver: Corrosion rate of less than 300 Å in 30 days</li> </ul>
<p><sup>1</sup> ASHRAE 52.2-2008 - <i>Method of Testing General Ventilation Air-Cleaning Devices for Removal Efficiency by Particle Size</i>. Atlanta: American Society of Heating, Refrigerating and Air-Conditioning Engineers, Inc.</p> <p><sup>2</sup> The deliquescent relative humidity of particulate contamination is the relative humidity at which the dust absorbs enough water to become wet and promote ionic conduction.</p> <p><sup>3</sup> ANSI/ISA-71.04-1985. <i>Environmental conditions for process measurement and control systems: Airborne contaminants</i>. Instrument Society of America, Research Triangle Park, North Carolina, U.S.A.</p>	

## Documentation format

The publications for this product are in Adobe Portable Document Format (PDF) and should be compliant with accessibility standards. If you experience difficulties when you use the PDF files and want to request a web-based format or accessible PDF document for a publication, direct your mail to the following address:

*Information Development  
 IBM Corporation  
 205/A015  
 3039 E. Cornwallis Road  
 P.O. Box 12195  
 Research Triangle Park, North Carolina 27709-2195  
 U.S.A.*

In the request, be sure to include the publication part number and title.

When you send information to IBM, you grant IBM a nonexclusive right to use or distribute the information in any way it believes appropriate without incurring any obligation to you.

---

## Telecommunication regulatory statement

This product may not be certified in your country for connection by any means whatsoever to interfaces of public telecommunications networks. Further certification may be required by law prior to making any such connection. Contact an IBM representative or reseller for any questions.

---

## Electronic emission notices

When you attach a monitor to the equipment, you must use the designated monitor cable and any interference suppression devices that are supplied with the monitor.

## Federal Communications Commission (FCC) statement

**Note:** This equipment has been tested and found to comply with the limits for a Class A digital device, pursuant to Part 15 of the FCC Rules. These limits are designed to provide reasonable protection against harmful interference when the equipment is operated in a commercial environment. This equipment generates, uses, and can radiate radio frequency energy and, if not installed and used in accordance with the instruction manual, may cause harmful interference to radio communications. Operation of this equipment in a residential area is likely to cause harmful interference, in which case the user will be required to correct the interference at his own expense.

Properly shielded and grounded cables and connectors must be used in order to meet FCC emission limits. IBM is not responsible for any radio or television interference caused by using other than recommended cables and connectors or by unauthorized changes or modifications to this equipment. Unauthorized changes or modifications could void the user's authority to operate the equipment.

This device complies with Part 15 of the FCC Rules. Operation is subject to the following two conditions: (1) this device may not cause harmful interference, and (2) this device must accept any interference received, including interference that might cause undesired operation.

## Industry Canada Class A emission compliance statement

This Class A digital apparatus complies with Canadian ICES-003.

## Avis de conformité à la réglementation d'Industrie Canada

Cet appareil numérique de la classe A est conforme à la norme NMB-003 du Canada.

## Australia and New Zealand Class A statement

**Attention:** This is a Class A product. In a domestic environment this product may cause radio interference in which case the user may be required to take adequate measures.

## European Union EMC Directive conformance statement

This product is in conformity with the protection requirements of EU Council Directive 2004/108/EC on the approximation of the laws of the Member States relating to electromagnetic compatibility. IBM cannot accept responsibility for any failure to satisfy the protection requirements resulting from a nonrecommended modification of the product, including the fitting of non-IBM option cards.

**Attention:** This is an EN 55022 Class A product. In a domestic environment this product may cause radio interference in which case the user may be required to take adequate measures.

Responsible manufacturer:

International Business Machines Corp.

New Orchard Road  
Armonk, New York 10504  
914-499-1900

European Community contact:

IBM Deutschland GmbH  
Technical Regulations, Department M372  
IBM-Allee 1, 71139 Ehningen, Germany  
Telephone: +49 7032 15 2941  
Email: lugi@de.ibm.com

## Germany Class A statement

### **Deutschsprachiger EU Hinweis: Hinweis für Geräte der Klasse A EU-Richtlinie zur Elektromagnetischen Verträglichkeit**

Dieses Produkt entspricht den Schutzanforderungen der EU-Richtlinie 2004/108/EG zur Angleichung der Rechtsvorschriften über die elektromagnetische Verträglichkeit in den EU-Mitgliedsstaaten und hält die Grenzwerte der EN 55022 Klasse A ein.

Um dieses sicherzustellen, sind die Geräte wie in den Handbüchern beschrieben zu installieren und zu betreiben. Des Weiteren dürfen auch nur von der IBM empfohlene Kabel angeschlossen werden. IBM übernimmt keine Verantwortung für die Einhaltung der Schutzanforderungen, wenn das Produkt ohne Zustimmung der IBM verändert bzw. wenn Erweiterungskomponenten von Fremdherstellern ohne Empfehlung der IBM gesteckt/eingebaut werden.

EN 55022 Klasse A Geräte müssen mit folgendem Warnhinweis versehen werden: **Warnung:** Dieses ist eine Einrichtung der Klasse A. Diese Einrichtung kann im Wohnbereich Funk-Störungen verursachen; in diesem Fall kann vom Betreiber verlangt werden, angemessene Maßnahmen zu ergreifen und dafür aufzukommen.

### **Deutschland: Einhaltung des Gesetzes über die elektromagnetische Verträglichkeit von Geräten**

Dieses Produkt entspricht dem Gesetz über die elektromagnetische Verträglichkeit von Geräten (EMVG). Dies ist die Umsetzung der EU-Richtlinie 2004/108/EG in der Bundesrepublik Deutschland.

### **Zulassungsbescheinigung laut dem Deutschen Gesetz über die elektromagnetische Verträglichkeit von Geräten (EMVG) (bzw. der EMC EG Richtlinie 2004/108/EG) für Geräte der Klasse A**

Dieses Gerät ist berechtigt, in Übereinstimmung mit dem Deutschen EMVG das EG-Konformitätszeichen - CE - zu führen.

Verantwortlich für die Einhaltung der EMV Vorschriften ist der Hersteller:

International Business Machines Corp.  
New Orchard Road  
Armonk, New York 10504  
914-499-1900

Der verantwortliche Ansprechpartner des Herstellers in der EU ist:

IBM Deutschland GmbH  
Technical Regulations, Abteilung M372  
IBM-Allee 1, 71139 Ehningen, Germany  
Telephone: +49 7032 15 2941  
Email: lugi@de.ibm.com

## Generelle Informationen:

Das Gerät erfüllt die Schutzanforderungen nach EN 55024 und EN 55022 Klasse A.

## Japan VCCI Class A statement

この装置は、クラス A 情報技術装置です。この装置を家庭環境で使用すると電波妨害を引き起こすことがあります。この場合には使用者が適切な対策を講ずるよう要求されることがあります。 VCCI-A

This is a Class A product based on the standard of the Voluntary Control Council for Interference (VCCI). If this equipment is used in a domestic environment, radio interference may occur, in which case the user may be required to take corrective actions.

## Japan Electronics and Information Technology Industries Association (JEITA) statement

高調波ガイドライン準用品

Japan Electronics and Information Technology Industries Association (JEITA) Confirmed Harmonics Guidelines with Modifications (products greater than 20 A per phase)

## Korea Communications Commission (KCC) statement

이 기기는 업무용(A급)으로 전자파적합기기로서 판매자 또는 사용자는 이 점을 주의하시기 바라며, 가정외의 지역에서 사용하는 것을 목적으로 합니다.

This is electromagnetic wave compatibility equipment for business (Type A). Sellers and users need to pay attention to it. This is for any areas other than home.

## Russia Electromagnetic Interference (EMI) Class A statement

ВНИМАНИЕ! Настоящее изделие относится к классу А. В жилых помещениях оно может создавать радиопомехи, для снижения которых необходимы дополнительные меры

## People's Republic of China Class A electronic emission statement

中华人民共和国“A类”警告声明

声明

此为A级产品，在生活环境中，该产品可能会造成无线电干扰。在这种情况下，可能需要用户对其干扰采取切实可行的措施。

## Taiwan Class A compliance statement

警告使用者：  
這是甲類的資訊產品，在居住的環境中使用時，可能會造成射頻干擾，在這種情況下，使用者會被要求採取某些適當的對策。





---

# Index

## A

- accessible documentation 209
- advanced configuration settings 12
- Advanced Management Module (AMM) 29
- advanced management module event log 85
- Advanced Settings Utility (ASU) 28
- advanced setup 12
- air baffle
  - installing 49
- array, SAS 53
- ASM event log 85
- assertion event, system-event log 85
- assistance, getting 203
- Australia Class A statement 210
- automated boot recovery 195

## B

- battery
  - replacing 51
- battery, removing 51
- bezel assembly
  - installing 46
- BGE 168
- BIOS update failure 192
- blade filler 42
- blade handle
  - installing 48
  - removing 47
- blade server 33
  - installing 42
  - removing 41
- blade server cover
  - closing 44
  - opening 43
- BladeCenter GPU expansion (BGE) unit
  - LED 168
- BladeCenter GPU expansion unit
  - light path diagnostics LEDs 169
- BladeCenter HS23E
  - specifications 2
- blank screen 154
- boot backup UEFI switch 9
- Boot IMM recovery partition switch 9
- Boot Menu program 16
- buttons
  - keyboard/video/mouse 3
  - media-tray select 3
  - power 3

## C

- Canada Class A electronic emission statement 210
- CFFh expansion card

- I/O expansion card 61, 63
- check out procedure 83
- checkout procedure 83
  - performing 84
- China Class A electronic emission statement 212
- CIoV-form-factor expansion card
  - I/O expansion card 60, 62
  - installing 62
  - removing 60
- Class A electronic emission notice 210
- collecting data xiii
- compact-form-factor expansion card
  - I/O expansion card 61, 63
  - installing 63
  - removing 61
- components
  - system board 7
- configuration
  - Configuration/Setup Utility 11
  - minimum 200
  - PXE Boot Agent Utility program 11
  - with ServerGuide 22
- configuring
  - Gigabit Ethernet controller 25
  - UEFI compatible devices 24
- configuring your blade server 11
- configuring your server 18
- connectors 7
  - I/O expansion card 7
  - memory 7
  - microprocessor 7
  - SAS hard disk drives 7
  - system board 7
- consumable and structural parts
  - removing and replacing 43
- contamination, particulate and gaseous 209
- control panel
  - installing 67
  - removing 66
  - supported 67
- controller
  - enable or disable Ethernet 12
  - enable or disable SCSI 12
- cover
  - closing 44
  - opening 43
- CPU stress test error codes
  - 089-801-xxx 178
  - 089-802-xxx 178
  - 089-901-xxx 178
- Create a software RAID array of hard disk drives 27
- creating
  - RAID array 26
- creating a personalized support web page 204
- creating a RAID array of hard disk drives 26

custom support web page 204

## D

data collection xiii

date and time 12

deassertion event, system-event log 85

description

SW1 - 2 system board switch 9

SW1 - 3 system board switch 9

SW1 - 4 system board switch 9

SW1 - 5 system board switch 9

SW1 - 6 system board switch 9

SW1 - 7 system board switch 9

SW1 - 8 system board switch 9

SW1- 1 system board switch 9

devices and I/O ports 12

diagnostic

error codes

000 172

programs, overview 170

programs, starting 170

text message format 171

diagnostic error codes 83

diagnostic text messages

aborted 171

failed 171

not applicable 171

passed 171

user aborted 171

warning 171

diagnostic tools 83–84

diagnostics 83

DIMM. 55

disabling USB in-band interface

from Advanced Management Module (AMM) 29

from IMM 29

display problems 154

documentation

format 209

using 204

documentation, related 1

drive

connectors 7

option, SAS 53

DSA log 85

DSA preboot diagnostic program 170

DSA, sending data to IBM 204

## E

electrical equipment, servicing vii

electronic emission Class A notice 210

error codes

CPU stress test 178

error codes and messages

diagnostic 172

SAS 196

UEFI/POST 87–88

error LEDs 164

error log 84

error logs

IMM event 86

viewing 86

error messages

front panel cable is not connected to system board 109

high-speed expansion card fault 109

I/O board fault 109

IMM 109

error symptoms

general 151

intermittent 152

monitor 154

optional devices 156

software 163

storage drive 151

USB port 164

video 154

errors

201-811-xxx 180

201-812-xxx 180

201-815-xxx 180

201-818-xxx 180

201-819-xxx 180

201-877-xxx 180

201-878-xxx 180

201-885-xxx 180

201-886-xxx 180

201-894-xxx 180

201-899-xxx 180

201-901-xxx 180

210-000-000 180

215-000-xxx 186

215-801-xxx 186

215-802-xxx 186

215-803-xxx 186

215-901-xxx 186

215-902-xxx 186

215-903-xxx 186

215-904-xxx 186

BIOS update 192

DIMM x error 166

format, diagnostic code 171

keyboard and mouse 192–193, 195, 197

light path diagnostic LEDs 166

LP1 166

LP2 166

media tray 197

memory 153

memory self tests 180

messages, diagnostic 170

microprocessor error 166

network connection 155, 199

NMI 166

optical drive self tests 186

optional device problems 156

power 159

power error messages 156

removable-media drive 161

S BRD 166

- SAS storage drive error 166
- service processor 163
- shared resource problems 196
- software 163
- storage drive self tests
  - 217-000-000 191
- tape alert flags
  - flag 2 191
- Temp 166
- UEFI update 192
- USB port 164
- video problems 200
- European Union EMC Directive conformance statement 210
- event log 84
- event logs 85
- exit configuration utility 12
- expansion unit
  - removing 68

## F

- FastSetup 11
- FCC Class A notice 210
- features
  - ServerGuide 21
- filler
  - blade 41
  - microprocessor heat sink 40
- filler, blade 42
- firmware updates 24
- force RTMM update switch 9
- forgotten power-on password, bypassing 16

## G

- gaseous contamination 209
- Germany Class A statement 211
- Gigabit Ethernet controller
  - configuring 25
- grease, thermal 78
- guidelines
  - servicing electrical equipment vii
  - trained service technicians vi

## H

- hard disk drive
  - connectors 7
  - hot swap, installing 53
  - problems 151
- hardware problems 84
- hardware service and support telephone numbers 205
- help
  - from the World Wide Web 204
  - from World Wide Web 204
  - sending diagnostic data to IBM 204
  - sources of 203
- hot-swap hard disk drive
  - removing 53
- hot-swap storage device

- SAS hard disk drive 53

## I

- I/O expansion card
  - CFFh 61, 63
  - CIOv-form-factor expansion card 60, 62
  - compact-form-factor expansion card 61, 63
  - connectors 7
- I/O-expansion cards
  - installing 62
  - removing 60
- IBM Taiwan product service 205
- IMM
  - LAN over USB 28
  - self-test error codes 172
- IMM error log
  - viewing from Setup utility 86
- IMM error messages 109
- IMM event log 85–86
- IMM self test error codes
  - 166-901-xxx 172
  - 166-902-xxx 172
  - 166-903-xxx 172
  - 166-904-xxx 172
  - 166-905-xxx 172
  - 166-906-xxx 172
  - 166-907-xxx 172
  - 166-908-xxx 172
  - 166-909-xxx 172
  - 166-910-xxx 172
  - 166-911-xxx 172
  - 166-912-xxx 172
- IMM TPM physical presence 9
- IMM2 controller settings 12
- important notices 208
- information center 204
- inspecting for unsafe conditions vi
- installation order for memory modules 55
- installing
  - air baffle 49
  - bezel assembly 46
  - blade handle 48
  - blade server 42
  - CFFh 63
  - CIOv-form-factor expansion card 62
  - compact-form-factor expansion card 63
  - control panel 67
  - hot-swap hard disk drives 53
  - I/O-expansion cards 62
  - memory module 55
  - optional expansion unit 69
  - options 39
  - SAS hard disk drive 53
  - storage interface card 65
  - system-board assembly 80
  - USB Flash key 59
- installing the battery 51
- installing the blade handle 48
- integrated functions 2

integrated management module event log 85  
intermittent problems 83, 152  
IPMI event log 85

## J

Japan Class A electronic emission statement 212  
Japan Electronics and Information Technology Industries  
Association statement 212  
JEITA statement 212  
jittery screen 154

## K

Korea Class A electronic emission statement 212

## L

LAN over USB  
conflicts 28  
description 28  
Linux driver 30  
manual configuration of 29  
settings 28  
Windows driver 30  
LAN over USB Linux driver 30  
LAN over USB Windows driver 30  
LEDs  
activity 3  
blade-error 3  
error, locations 164  
information 3  
light path diagnostics, viewing without power 164  
light path, locations 164  
location 3  
power 3  
system board 9  
light path diagnostics 164  
Light path diagnostics 84  
light path diagnostics LEDs 166  
BladeCenter GPU expansion unit 169  
light path diagnostics panel 9  
light path LED locations 164  
load default settings 12  
LSI Configuration Utility program 26  
LSI logic configuration utility program  
description 11

## M

media tray errors 197  
media-tray select button 3  
memory  
configuration changes 55  
specifications 2  
memory module  
installing 55  
order of installation 55  
removing 54  
specifications 2

supported 2, 55  
memory problems 153  
memory settings 12  
messages  
diagnostic 170  
messages, error  
POST 87  
microprocessor  
connectors 7  
installation guidelines 73  
removal guidelines 70  
specifications 2  
microprocessor options 12  
microprocessor problems 83  
minimum configuration 200  
monitor problems 154

## N

network connection problems 155, 199  
Network operating system (NOS) installation  
with ServerGuide 22  
New Zealand Class A statement 210  
NOS installation  
without ServerGuide 23  
notes, important 208  
notices 207  
electronic emission 210  
FCC, Class A 210  
Nx boot failure 196

## O

opening the blade server cover 43  
operating system  
installing 22  
option  
installing 39  
optional expansion unit  
installing 69  
order of installation for memory modules 55

## P

particulate contamination 209  
parts listing 33, 37  
password  
power-on 16  
password override switch 9  
PCH RTC reset switch 9  
PCI bus control settings 12  
People's Republic of China Class A electronic emission  
statement 212  
POST  
about 85  
error codes 87  
error log 86  
POST event log 85  
power errors 156  
power problems 159

- power-on password 16
- Preboot eXecution Environment (PXE) option 12
  - disabling 12
  - enabling 12
- problem determination tips 201
- problems
  - general 151
  - hardware 84
  - intermittent 152
  - keyboard 153
  - memory 153
  - monitor 154
  - mouse 153
  - network connection 155
  - optional devices 156
  - power 159
  - service processor 163
  - software 163
  - storage drive 151
  - UEFI/POST 88
  - undetermined 200
  - USB port 164
  - video 154
- processor summary information 12
- product data 12
- product service, IBM Taiwan 205
- publications
  - related 1
- PXE boot agent utility program 11
  - using 23

## R

- recovering from a BIOS failure 192
- recovering from a UEFI failure 192
- redundant array of independent disks (RAID)
  - SAS array 53
- related documentation 1
- remote console redirection 12
- removable-media drive
  - errors 161
- removing
  - air baffle 48
  - bezel assembly 45
  - blade handle 47
  - blade server 41
  - CFFh 61
  - CIOv-form-factor expansion card 60
  - compact-form-factor expansion card 61
  - control panel 66
  - hot-swap hard disk drive 53
  - I/O-expansion cards 60
  - memory module 54
  - SAS controller 64
  - storage interface card 64
  - USB Flash key 59
- removing a microprocessor and heat sink 70
- removing and replacing
  - consumable and structural parts 43
- removing and replacing blade server components

- customer replaceable unit (CRU) 39
  - Tier 1 CRU 39
  - Tier 2 CRU 39
- removing and replacing CRUs 50
- removing the air baffle 48
- removing the bezel assembly 45
- removing the blade handle 47
- replacing
  - battery 51
  - system-board assembly 78
  - thermal grease 78
- replacing consumable and structural parts 43
- restore settings 12
- returning a device or component 41
- Russia Class A electronic emission statement 212

## S

- safety v
- safety statements v, viii
- SAS
  - array
    - type supported 53
  - SAS error messages 196
  - SAS hard disk drive
    - hot-swap storage device 53
    - installing 53
  - save settings 12
  - screen jitter 154
  - SCSI 53
  - sending diagnostic data to IBM 204
  - Serial Attached SCSI (SAS)
    - hard disk drive
      - connectors 7
      - hot-swap hard disk drive
        - installing 53
  - ServeRAID H1135 configuration utility 25
  - ServerGuide
    - error symptoms 162
    - features 21
    - network operating system (NOS) installation 22
    - using 21
  - service and support
    - before you call 203
    - hardware 205
    - software 204
  - service bulletins 83
  - service processor problems 163
  - servicing electrical equipment vii
  - setting option ROM execution order 28
  - setup
    - with ServerGuide 22
  - Setup utility 11, 18
  - software problems 163
  - software service and support telephone numbers 204
  - solving problems 83
  - specifications
    - BladeCenter HS23E 2
  - start options 12
  - starting the blade server 6

- Starting the HII Configuration Application 26
- startup sequence options 12
- startup sequence, setting 12
- static electricity 40
- static-sensitive devices, handling 40
- stopping the blade server 7
- storage drive
  - connectors 7
  - problems 151
- storage interface card 64
  - installing 65
  - removing 64
  - SAS controller 64
- structural parts 37
- support web page, custom 204
- SW1 - 2 system board switch
  - description 9
- SW1 - 3 system board switch
  - description 9
- SW1 - 4 system board switch
  - description 9
- SW1 - 5 system board switch
  - description 9
- SW1 - 6 system board switch
  - description 9
- SW1 - 7 system board switch
  - description 9
- SW1 - 8 system board switch
  - description 9
- SW1-1 system board switch
  - description 9
- system board
  - LEDs 9
  - switches 8
- system board layouts 7
- system information 12
- system MAC addresses 12
- system reliability 40
- system security 12
- system summary information 12
- system-board assembly
  - replacement 78
- system-board connectors 7
- system-event log 85

## T

- Taiwan Class A electronic emission statement 213
- telecommunication regulatory statement 210
- telephone numbers 204–205
- thermal grease
  - heat sink 73
- thermal grease, replacing 78
- TPM physical presence switch 9
- trademarks 207
- trained service technicians, guidelines vi
- troubleshooting
  - Light path diagnostics 84
  - Problem isolation tables 84
  - service bulletins 83

- troubleshooting tables 150
- turning off the blade server 7
- turning on the blade server 6

## U

- UEFI
  - error codes 87
- UEFI compatible devices
  - configuring 24
- UEFI update failure 192
- UEFI/POST error codes 88
- unable to communicate 155
- undetermined problems 200
- undocumented problems xvi
- United States FCC Class A notice 210
- Universal Serial Bus (USB) problems 164
- universal unique identifier, updating 16
- unsafe conditions, inspecting for vi
- updating
  - universal unique identifier 16
  - updating firmware 24
  - updating the DMI/SMBIOS data 18
    - Setup utility 18
- USB Flash key
  - installing 59
  - removing 59
  - supported 59
- USB in-band interface, disabling 29
- utility
  - PXE boot agent program, using 23
  - Setup utility 11

## V

- video problems 154
- viewing event logs 86
- viewing the test results 171

## W

- Web site
  - ServerGuide 21
- wrong characters 154





Part Number: 00KC020

Printed in China

(1P) P/N: 00KC020

