



ThinkSystem D3 V2 Chassis User Guide



Machine Type: 7DGW, 7DGX

Note

Before using this information and the product it supports, be sure to read and understand the safety information and the safety instructions, which are available at:

https://pubs.lenovo.com/safety_documentation/

In addition, be sure that you are familiar with the terms and conditions of the Lenovo warranty for your server, which can be found at:

<http://datacentersupport.lenovo.com/warrantylookup>

First Edition (November 2024)

© Copyright Lenovo 2024.

LIMITED AND RESTRICTED RIGHTS NOTICE: If data or software is delivered pursuant to a General Services Administration (GSA) contract, use, reproduction, or disclosure is subject to restrictions set forth in Contract No. GS-35F-05925.

Contents

Contents	i
---------------------------	----------

Safetyiii
-------------------------	-------------

Safety inspection checklist	iv
---------------------------------------	----

Chapter 1. ThinkSystem D3 V2

Chassis	1
--------------------------	----------

Features	1
--------------------	---

Tech Tips	2
---------------------	---

Security advisories	2
-------------------------------	---

Chassis specifications	3
----------------------------------	---

Chapter 2. Chassis components **5**

Chassis front view	5
------------------------------	---

Four 1U nodes	5
-------------------------	---

Chassis rear view	5
-----------------------------	---

Chassis midplane	6
----------------------------	---

Power supply LED	8
----------------------------	---

Chapter 3. Parts list **9**

Power cords	10
-----------------------	----

Chapter 4. Unboxing and setup **11**

System package contents	11
-----------------------------------	----

Identify the chassis	11
--------------------------------	----

Chapter 5. Hardware replacement procedures **13**

Installation Guidelines	13
-----------------------------------	----

Safety inspection checklist	14
---------------------------------------	----

System reliability guidelines	15
---	----

Handling static-sensitive devices	15
---	----

Power on and power off the system	16
---	----

Power on the system	16
-------------------------------	----

Power off the system	16
--------------------------------	----

Chassis replacement	17
-------------------------------	----

Remove the chassis from the rack	17
--	----

Install the chassis to the rack	20
---	----

Replace components in the chassis	24
---	----

EIA bracket replacement	24
-----------------------------------	----

Hot-swap power supply replacement	26
---	----

PSU cage and chassis midplane

replacement	33
-----------------------	----

Chapter 6. Update the firmware. **43**

Appendix A. Hardware disassembling for recycle **47**

Disassemble the chassis for recycle	47
---	----

Appendix B. Getting help and technical assistance **49**

Collecting service data	49
-----------------------------------	----

Contacting Support	50
------------------------------	----

Appendix C. Documents and supports **51**

Documents download	51
------------------------------	----

Support websites	51
----------------------------	----

Appendix D. Notices. **53**

Trademarks	54
----------------------	----

Important notes	54
---------------------------	----

Electronic emission notices	54
---------------------------------------	----

Taiwan Region BSMI RoHS declaration	55
---	----

Taiwan import and export contact information	55
--	----

Safety

Before installing this product, read the Safety Information.

قبل تركيب هذا المنتج، يجب قراءة الملاحظات الأمنية

Antes de instalar este produto, leia as Informações de Segurança.

在安装本产品之前，请仔细阅读 Safety Information（安全信息）。

安裝本產品之前，請先閱讀「安全資訊」。

Prije instalacije ovog produkta obavezno pročitajte Sigurnosne Upute.

Před instalací tohoto produktu si přečtěte příručku bezpečnostních instrukcí.

Læs sikkerhedsforskrifterne, før du installerer dette produkt.

Lees voordat u dit product installeert eerst de veiligheidsvoorschriften.

Ennen kuin asennat tämän tuotteen, lue turvaohjeet kohdasta Safety Information.

Avant d'installer ce produit, lisez les consignes de sécurité.

Vor der Installation dieses Produkts die Sicherheitshinweise lesen.

Πριν εγκαταστήσετε το προϊόν αυτό, διαβάστε τις πληροφορίες ασφάλειας (safety information).

לפני שתתקינו מוצר זה, קראו את הוראות הבטיחות.

A termék telepítése előtt olvassa el a Biztonsági előírásokat!

Prima di installare questo prodotto, leggere le Informazioni sulla Sicurezza.

製品の設置の前に、安全情報をお読みください。

본 제품을 설치하기 전에 안전 정보를 읽으십시오.

Пред да се инсталира овој продукт, прочитајте информацијата за безбедност.

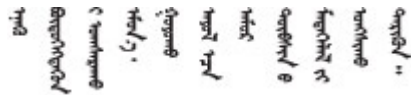

Les sikkerhetsinformasjonen (Safety Information) før du installerer dette produktet.

Przed zainstalowaniem tego produktu, należy zapoznać się z książką "Informacje dotyczące bezpieczeństwa" (Safety Information).

Antes de instalar este produto, leia as Informações sobre Segurança.

Перед установкой продукта прочтите инструкции по технике безопасности.

Pred inštaláciou tohto zariadenia si pečítajte Bezpečnostné predpisy.

Pred namestitvijo tega proizvoda preberite Varnostne informacije.

Antes de instalar este producto, lea la información de seguridad.

Läs säkerhetsinformationen innan du installerar den här produkten.

ཐོན་ཇུས་འདི་བདེ་སྤྱོད་མ་བྱས་གོང་། སྐྱོར་གྱི་ཡིད་གཟབ་
བྱ་འདྲ་མིན་ཡོད་པའི་འོད་ཟེར་བལྟ་དགོས།

Bu ürünü kurmadan önce güvenlik bilgilerini okuyun.

مەزكۇر مەھسۇلاتنى ئورنىتىشتىن بۇرۇن بىخەتەرلىك ئۇچۇرلىرىنى ئوقۇپ چىقىڭ.

Youq mwngz yungh canjbinj neix gaxgonq, itdingh aeu doeg aen
canjbinj soengq cungj vahgangj ancien siusik.

Safety inspection checklist

Use the information in this section to identify potentially unsafe conditions with your system. As each machine was designed and built, required safety items were installed to protect users and service technicians from injury.

Note: The product is not suitable for use at visual display workplaces according to §2 of the Workplace Regulations.

Attention: This is a Class A product. In a domestic environment, this product may cause radio interference in which case the user may be required to take adequate measures.

Note: The set-up of the server is made in the server room only.

CAUTION:

This equipment must be installed or serviced by trained personnel, as defined by the NEC, IEC 62368-1 & IEC 60950-1, the standard for Safety of Electronic Equipment within the Field of Audio/Video, Information Technology and Communication Technology. Lenovo assumes you are qualified in the servicing of equipment and trained in recognizing hazards energy levels in products. Access to the equipment is by the use of a tool, lock and key, or other means of security, and is controlled by the authority responsible for the location.

Important: Electrical grounding of the system is required for operator safety and correct system function. Proper grounding of the electrical outlet can be verified by a certified electrician.

Use the following checklist to verify that there are no potentially unsafe conditions:

1. Make sure that the power is off and the power cord is disconnected.
2. Check the power cord.
 - Make sure that the third-wire ground connector is in good condition. Use a meter to measure third-wire ground continuity for 0.1 ohm or less between the external ground pin and the frame ground.
 - Make sure that the power cord is the correct type.

To view the power cords that are available for the server:

a. Go to:

<http://dcsc.lenovo.com/#/>

b. Click **Preconfigured Model** or **Configure to order**.

c. Enter the machine type and model for your server to display the configurator page.

d. Click **Power → Power Cables** to see all line cords.

- Make sure that the insulation is not frayed or worn.

3. Check for any obvious non-Lenovo alterations. Use good judgment as to the safety of any non-Lenovo alterations.
4. Check inside the server for any obvious unsafe conditions, such as metal filings, contamination, water or other liquid, or signs of fire or smoke damage.
5. Check for worn, frayed, or pinched cables.
6. Make sure that the power-supply cover tighteners (screws or rivets) have not been removed or tampered with.

Chapter 1. ThinkSystem D3 V2 Chassis

The ThinkSystem D3 V2 Chassis and nodes are designed for high performance computing. This system includes a single chassis that can contain up to four 1U ThinkSystem high-density servers, which are designed to deliver a dense, scalable platform for distributed enterprise and hyperconverged systems.



Figure 1. ThinkSystem D3 V2 Chassis installed with four SD520 V4 nodes

Features

Performance, ease of use, reliability, and expansion capabilities were key considerations in the design of your system. These design features make it possible for the user to customize the system hardware to meet the needs today and provide flexible expansion capabilities for the future.

Chassis features

- **Redundant optional power capabilities**

The chassis supports up to three hot-swap CRPS power supplies, which provide redundancy.

Important:

- CRPS power supply units in the chassis must have the same vendor, wattage, and part number (or alternate part number).
- CRPS Premium (CFFv5) power supply units in the chassis must have the same wattage, and part number (or alternate part number).

- **Chassis management**

The chassis midplane with PSoC (Programmable System on Chip) allows monitor and management of nodes and power supply units in the chassis. A **chassis caretaker node** is selected by the PSoC firmware for chassis management.

For the management interface, see <https://pubs.lenovo.com/lxcc-overview/>. In XCC, certain management functions can only be performed by the caretaker node, whereas other functions can be performed by all nodes.

Function	Caretaker node ¹	Other nodes
<ul style="list-style-type: none">– Supported: ✓– Unsupported: X		
PSoC firmware update	✓	X

1. By default, the **caretaker node** is automatically selected by the PSoC firmware on the chassis midplane. To change the chassis caretaker preference, see https://pubs.lenovo.com/xcc3/NN1ia_c_d3_chassis.

Function	Caretaker node ²	Other nodes
PSU firmware update ³	✓	X
Virtual reseal/reset for all nodes in the chassis	✓	X
View PSU inventory and events	✓	X
View chassis VPD and PSoC firmware versions	✓	✓
View PSU present status	✓	✓
View information of chassis and all nodes	✓	✓
Virtual reseal / reset for the current node itself	✓	✓
View the change history of the caretaker node	✓	✓
View the history of node installation / removal	✓	✓
View or participate in the caretaker node selection	✓	✓

Tech Tips

Lenovo continually updates the support website with the latest tips and techniques that you can use to solve issues that your server might encounter. These Tech Tips (also called retain tips or service bulletins) provide procedures to work around issues or solve problems related to the operation of your server.

To find the Tech Tips available for your server:

1. Go to <http://datacentersupport.lenovo.com> and navigate to the support page for your server.
2. Click on **How To's** from the navigation pane.
3. Click **Article Type** → **Solution** from the drop-down menu.

Follow the on-screen instructions to choose the category for the problem that you are having.

Security advisories

Lenovo is committed to developing products and services that adhere to the highest security standards in order to protect our customers and their data. When potential vulnerabilities are reported, it is the responsibility of the Lenovo Product Security Incident Response Team (PSIRT) to investigate and provide information to our customers so they may put mitigation plans in place as we work toward providing solutions.

The list of current advisories is available at the following site:

https://datacentersupport.lenovo.com/product_security/home

-
2. By default, the **caretaker node** is automatically selected by the PSoC firmware on the chassis midplane. To change the chassis caretaker preference, see https://pubs.lenovo.com/xcc3/NN1ia_c_d3_chassis.
 3. Only the caretaker node can perform PSU firmware update.

Chassis specifications

Summary of the specifications of the chassis.

Technical specifications

Table 1. Chassis technical specifications

Specification	Description
Electrical input	<p>The system supports up to three hot-swap power supplies:</p> <ul style="list-style-type: none">• CRPS 1300-watt Titanium v1.1, input power 200-240V• CRPS 2700-watt Platinum v1.3, input power 200-240V• CRPS 2700-watt Platinum v1.4, input power 200-240V• CRPS Premium (CFFv5) 2000-watt Titanium, input power 200-240V• CRPS Premium (CFFv5) 2700-watt Titanium, input power 200-240V <p>Supported power supply configurations:</p> <ul style="list-style-type: none">• 3 PSUs: 2+1 (optional redundancy)• 2 PSUs: 1+1 (optional redundancy)• 1 PSU: 1+0 (only supported on CRPS Premium (CFFv5) 2700-watt Titanium) <p>Notes:</p> <ul style="list-style-type: none">• CRPS Premium (CFFv5) PSUs support over-subscription.• The actual power efficiency depends on system configuration. <p>Important:</p> <ul style="list-style-type: none">• CRPS power supply units in the chassis must have the same vendor, wattage, and part number (or alternate part number).• CRPS Premium (CFFv5) power supply units in the chassis must have the same wattage, and part number (or alternate part number).

Mechanical specifications

Important: For safety, make sure that there is no node or power supply unit installed in the chassis when removing or installing the chassis from or to the rack.

Table 2. Chassis mechanical specifications

Specification	Description
Dimension	<p>2U rack-mounted chassis (2U4N)</p> <ul style="list-style-type: none">• Height: 87 mm (3.43 inches)• Depth: 898 mm (35.36 inches)• Width: 448 mm (17.64 inches)• Weight:<ul style="list-style-type: none">– Empty chassis (with chassis midplane and PSU cage): 11.83 kg (26.08 lbs)– Maximum (with four 1U nodes and three CRPS power supplies installed): approximately 42.37 kg (93.41 lbs)

Note: For the supported nodes for the chassis, see [“Chassis front view” on page 5](#).

Chapter 2. Chassis components

This section contains information about each of the chassis components.

Chassis front view

This section contains information on the front of the chassis installed with nodes.

The chassis can contain up to four 1U nodes.

Important:

- For proper cooling, each node tray must be installed with either a node or node tray fillers before the nodes in the chassis are powered on.
- The installation of nodes must follow the sequence of the tray numbering.

Four 1U nodes

For four 1U nodes: the two nodes in the right trays (**2** and **4**) must be installed upside down.

The following illustration shows the front view of the chassis and respective node trays in the chassis.

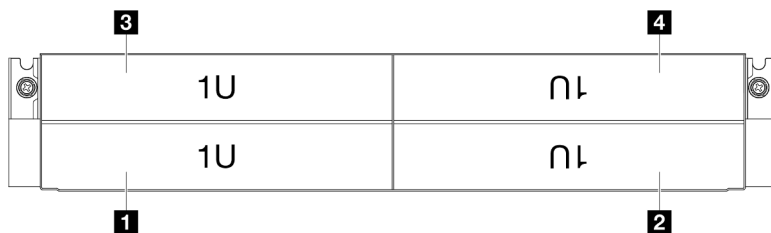

Figure 2. Chassis front view with four 1U nodes

3 Node tray 3	4 Node tray 4
1 Node tray 1	2 Node tray 2

Chassis rear view

This section contains information on the rear of the chassis.

Notes:

- Depending on the specific configuration, the hardware might look slightly different from the illustrations in this section.

Important:

- For proper cooling, each node tray must be installed with either a node or node tray fillers before the nodes in the chassis are powered on.

Chassis rear view

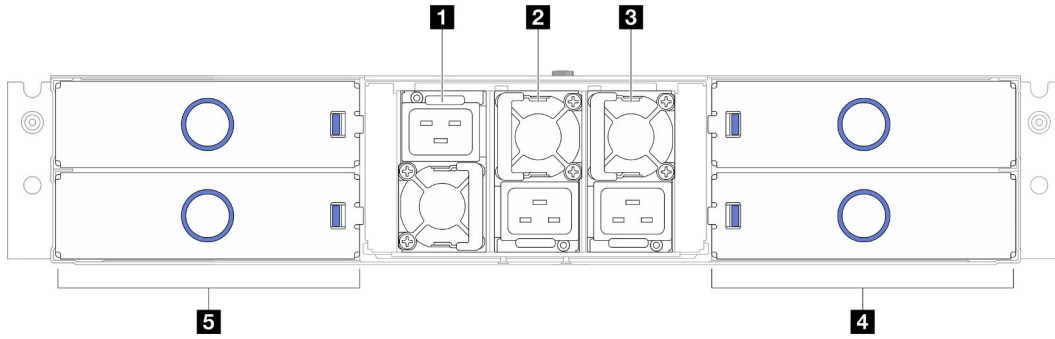

Figure 3. Chassis rear view

Table 3. Components on the rear of the chassis

1 PSU slot 1 (the PSU must be installed with the fan downward)	2 PSU slot 2 (the PSU must be installed with the fan upward)
3 PSU slot 3 (the PSU must be installed with the fan upward)	4 Node trays (the nodes must be installed right-side up)
5 Node trays (the nodes must be installed upside down)	

1 / **2** / **3** PSU slots

Install power supply units to these slots, connect them to power cords. Make sure the power cords are connected properly.

Important: When installing the power supply units, make sure to follow the instruction on the label in each slot.

- For slot 1 (**1**), the PSU must be installed with the fan downward.
- For slots 2 and 3 (**2** and **3**), the PSU must be installed with the fan upward.

Following are the power supplies supported by the system:

- CRPS 1300-watt Titanium v1.1, input power 200-240V
- CRPS 2700-watt Platinum v1.3, input power 200-240V
- CRPS 2700-watt Platinum v1.4, input power 200-240V
- CRPS Premium (CFFv5) 2000-watt Titanium, input power 200-240V
- CRPS Premium (CFFv5) 2700-watt Titanium, input power 200-240V

For more information on the power supply LED, see [“Power supply LED” on page 8](#).

Chassis midplane

The following illustration shows the location and connectors of the chassis midplane.

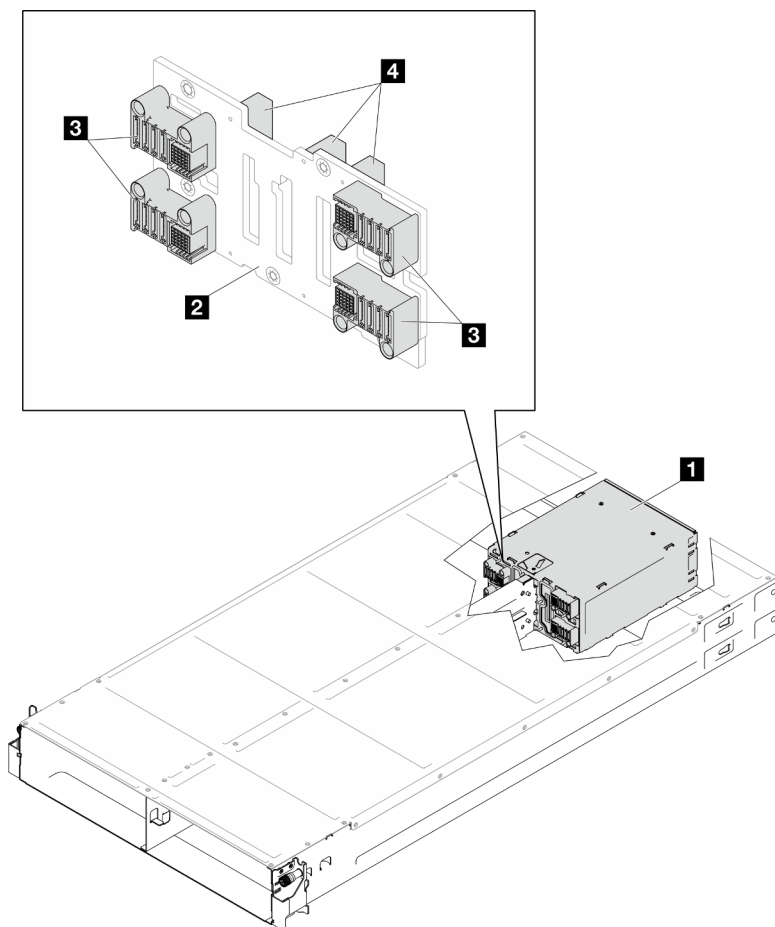

Figure 4. Chassis midplane location and connectors

1 PSU cage	3 PDB connectors
2 Chassis midplane	4 PSU connectors

1 PSU cage: For the PSU slots, see [“Chassis rear view”](#) on page 5.

2 Chassis midplane: For the replacement of the PSU cage and Chassis midplane, see [“PSU cage and chassis midplane replacement”](#) on page 33.

3 PDB connectors: When a node is installed in the chassis, the power distribution board (PDB) in the node is connected to the corresponding connector on the chassis midplane.

4 PSU connectors: When a hot-swap power supply unit (PSU) is installed in the PSU cage, the PSU is connected to the corresponding connector on the chassis midplane.

Notes:

- The firmware of the chassis midplane can be updated via Lenovo XClarity Controller (XCC) and Lenovo XClarity Essentials OneCLI (LXCE OneCLI). **Only the caretaker node can perform this update.**
- By default, the **caretaker node** is automatically selected by the PSoC firmware on the chassis midplane. To change the chassis caretaker preference, see https://pubs.lenovo.com/xcc3/NN1ia_c_d3_chassis.
- Go to [Chapter 6 “Update the firmware”](#) on page 43 for more information on firmware updating tools.

Power supply LED

This topic provides information about various power supply LED status and corresponding action suggestions.

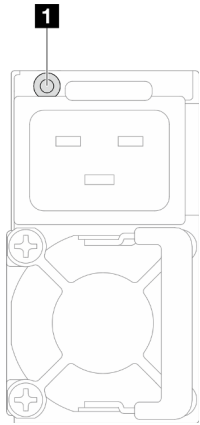

Figure 5. Power supply LED

LED	Description
1 Power supply status	<p>The power supply status LED can be in one of the following states:</p> <ul style="list-style-type: none">• Green: The power supply is connected to the AC power source and working normally.• Off: The power supply is disconnected from the AC power source.• Slow blinking green (about one flash every second): The power supply is in PSU standby state with AC present, cold standby state, or always standby state.• Amber: The AC power cord is unplugged, AC power lost (with a second power supply in parallel still in AC power input power), or power supply has failed. To resolve the issue, replace the power supply.• Slow blinking amber (about one flash every second): Power supply warning events where the power supply continues to operate.

Chapter 3. Parts list

Identify each of the components that is available for your system with the parts list.

For more information about ordering parts:

1. Go to <http://datacentersupport.lenovo.com> and navigate to the support page for your node or chassis.
2. Click **Parts**.
3. Enter the serial number to view a listing of parts for your system.

It is highly recommended that you check the power summary data for your server using Lenovo Capacity Planner before purchasing any new parts.

Note: Depending on the model, your server components might look slightly different from the illustration.

The parts listed in the following tables are identified as one of the following:

- **T1:** Tier 1 customer replaceable unit (CRU). Replacement of Tier 1 CRUs is your responsibility. If Lenovo installs a Tier 1 CRU at your request with no service agreement, you will be charged for the installation.
- **T2:** Tier 2 customer replaceable unit (CRU). You may install a Tier 2 CRU yourself or request Lenovo to install it, at no additional charge, under the type of warranty service that is designated for your server.
- **F:** Field replaceable unit (FRU). FRUs must be installed only by trained service technicians.
- **C:** Consumable and Structural parts. Purchase and replacement of consumable and structural parts is your responsibility. If Lenovo acquires or installs a structural component at your request, you will be charged for the service.

Chassis components

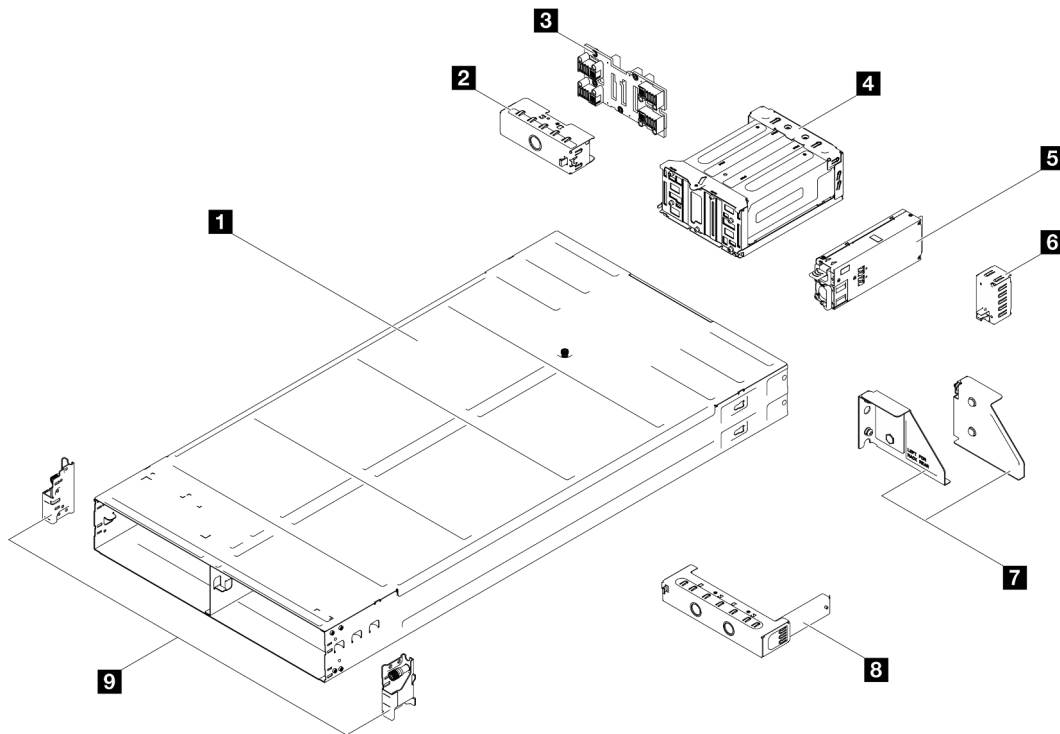

Figure 6. Chassis components

Description	Type
1 Chassis	T2
2 Node tray rear filler	T1
3 Chassis midplane	T2
4 PSU cage	T1
5 CRPS power supply unit	T2
6 PSU filler	T1
7 Chassis rear shipping brackets (left and right)	T1
8 Node tray front filler	T1
9 Chassis front EIA brackets (left and right)	T1

Power cords

Several power cords are available, depending on the country and region where the server is installed.

To view the power cords that are available for the server:

1. Go to:
<http://dcsc.lenovo.com/#/>
2. Click **Preconfigured Model** or **Configure to order**.
3. Enter the machine type and model for your server to display the configurator page.
4. Click **Power** → **Power Cables** to see all line cords.

Notes:

- For your safety, a power cord with a grounded attachment plug is provided to use with this product. To avoid electrical shock, always use the power cord and plug with a properly grounded outlet.
- Power cords for this product that are used in the United States and Canada are listed by Underwriter's Laboratories (UL) and certified by the Canadian Standards Association (CSA).
- For units intended to be operated at 115 volts: Use a UL-listed and CSA-certified cord set consisting of a minimum 18 AWG, Type SVT or SJT, three-conductor cord, a maximum of 15 feet in length and a parallel blade, grounding-type attachment plug rated 15 amperes, 125 volts.
- For units intended to be operated at 230 volts (U.S. use): Use a UL-listed and CSA-certified cord set consisting of a minimum 18 AWG, Type SVT or SJT, three-conductor cord, a maximum of 15 feet in length and a tandem blade, grounding-type attachment plug rated 15 amperes, 250 volts.
- For units intended to be operated at 230 volts (outside the U.S.): Use a cord set with a grounding-type attachment plug. The cord set should have the appropriate safety approvals for the country in which the equipment will be installed.
- Power cords for a specific country or region are usually available only in that country or region.

Chapter 4. Unboxing and setup

Information in this section assists you on unboxing and setting up the system. When unboxing the chassis and node, check if the items in the package are correct, and learn where to find information of system serial number and Lenovo XClarity Controller access.

System package contents

When you receive your system, verify that the shipment contains everything that you expected to receive.

The system package includes the following items:

- Node
- Chassis
- Rail installation kit*. Installation guide is provided in the package.
- Material box, including items such as power cords*, accessory kit, and printed documents.

Notes:

- Some of the items listed are available on select models only.
- Items marked with asterisk(*) are optional.

If any item is missing or damaged, contact your place of purchase. Make sure that you retain your proof of purchase and packing material. They might be required to receive warranty service.

Identify the chassis

This section contains instruction on how to identify your chassis.

Identifying your chassis

When you contact Lenovo for help, the machine type, model, and serial number information help support technicians to identify your system and provide faster service.

The illustration below shows the location of the ID label which contains the chassis model number, machine type, and serial number of the chassis. You can also add other system information labels to the front of the node in the customer label spaces.

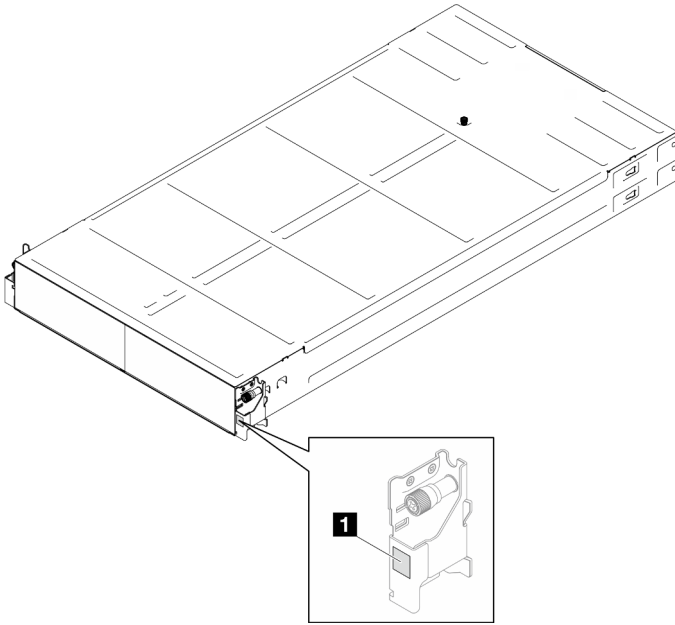

Figure 7. Location of the ID label on the chassis

Table 4. ID label on the front of the chassis

1 ID label

Chapter 5. Hardware replacement procedures

This section provides installation and removal procedures for all serviceable system components. Each component replacement procedure references any tasks that need to be performed to gain access to the component being replaced.

Installation Guidelines

Before installing components in your node or chassis, read the installation guidelines.

Before installing optional devices, read the following notices carefully:

Attention: Prevent exposure to static electricity, which might lead to system halt and loss of data, by keeping static-sensitive components in their static-protective packages until installation, and handling these devices with an electrostatic-discharge wrist strap or other grounding system.

- Read the safety information and guidelines to ensure your safety at work:
 - A complete list of safety information for all products is available at:
https://pubs.lenovo.com/safety_documentation/
 - The following guideline is also available at: “[Handling static-sensitive devices](#)” on page 15.
- Make sure the components you are installing are supported by your system.
 - For a list of supported optional components for the system, see <https://serverproven.lenovo.com>.
 - For the option package contents, see <https://serveroption.lenovo.com/>.
- For more information about ordering parts:
 1. Go to <http://datacentersupport.lenovo.com> and navigate to the support page for your node or chassis.
 2. Click **Parts**.
 3. Enter the serial number to view a listing of parts for your system.
- When you install a new node, download and apply the latest firmware. This will help ensure that any known issues are addressed, and that your node is ready to work with optimal performance. Go to the [Drivers and Software download website](#) of the specific node to download the latest firmware and driver updates.

Important: Some cluster solutions require specific code levels or coordinated code updates. If the component is part of a cluster solution, verify the latest Best Recipe code level menu for cluster supported firmware and driver before you update the code.

- If you replace a part, such as an adapter, that contains firmware, you might also need to update the firmware for that part. For more information about updating firmware, see “Update the firmware” in *User Guide* or *System Configuration Guide* of the specific node.
- It is good practice to make sure that the system is working correctly before installing an optional component.
- Keep the working area clean, and place the removed components on a flat and smooth surface that does not shake or tilt.
- Do not attempt to lift an object that might be too heavy for you. If you have to lift a heavy object, read the following precautions carefully:
 - Make sure that you can stand steadily without slipping.
 - Distribute the weight of the object equally between your feet.

- Use a slow lifting force. Never move suddenly or twist when you lift a heavy object.
- To avoid straining the muscles in your back, lift by standing or by pushing up with your leg muscles.
- Back up all important data before you make changes related to the disk drives.
- Have a small flat-blade screwdriver, a small Phillips screwdriver, and a T30 torx screwdriver available.
- To view the error LEDs on the system board (system board assembly) and internal components, leave the power on.
- You do not have to turn off the node to remove or install hot-swap power supplies, hot-swap drives, or hot-plug USB devices. However, you must turn off the node and remove it from the chassis before performing any steps that involve removing or installing components or cables inside the node.
- When replacing power supply units, make sure to refer to redundancy rules.
- Blue on a component indicates touch points, where you can grip to remove a component from or install it in the server, open or close a latch, and so on.
- Except PSU, orange on a component or an orange label on or near a component indicates that the component can be hot-swapped if the server and operating system support hot-swap capability, which means that you can remove or install the component while the server is still running. (Orange can also indicate touch points on hot-swap components.) See the instructions for removing or installing a specific hot-swap component for any additional procedures that you might have to perform before you remove or install the component.
- PSU with a release tab is a hot-swap PSU. The color of the release tab does not affect the serviceability of the PSU.
- The red strip on the drives, adjacent to the release latch, indicates that the drive can be hot-swapped if the server and operating system support hot-swap capability. This means that you can remove or install the drive while the server is still running.

Note: See the system specific instructions for removing or installing a hot-swap drive for any additional procedures that you might need to perform before you remove or install the drive.

- After finishing working on the node or chassis, make sure to reinstall all safety shields, guards, labels, and ground wires.

Safety inspection checklist

Use the information in this section to identify potentially unsafe conditions with your system. As each machine was designed and built, required safety items were installed to protect users and service technicians from injury.

Note: The product is not suitable for use at visual display workplaces according to §2 of the Workplace Regulations.

Attention: This is a Class A product. In a domestic environment, this product may cause radio interference in which case the user may be required to take adequate measures.

Note: The set-up of the server is made in the server room only.

CAUTION:

This equipment must be installed or serviced by trained personnel, as defined by the NEC, IEC 62368-1 & IEC 60950-1, the standard for Safety of Electronic Equipment within the Field of Audio/Video, Information Technology and Communication Technology. Lenovo assumes you are qualified in the servicing of equipment and trained in recognizing hazards energy levels in products. Access to the equipment is by the use of a tool, lock and key, or other means of security, and is controlled by the authority responsible for the location.

Important: Electrical grounding of the system is required for operator safety and correct system function. Proper grounding of the electrical outlet can be verified by a certified electrician.

Use the following checklist to verify that there are no potentially unsafe conditions:

1. Make sure that the power is off and the power cord is disconnected.
2. Check the power cord.
 - Make sure that the third-wire ground connector is in good condition. Use a meter to measure third-wire ground continuity for 0.1 ohm or less between the external ground pin and the frame ground.
 - Make sure that the power cord is the correct type.

To view the power cords that are available for the server:

- a. Go to:
 - <http://dcsc.lenovo.com/#/>
 - b. Click **Preconfigured Model** or **Configure to order**.
 - c. Enter the machine type and model for your server to display the configurator page.
 - d. Click **Power → Power Cables** to see all line cords.
- Make sure that the insulation is not frayed or worn.
3. Check for any obvious non-Lenovo alterations. Use good judgment as to the safety of any non-Lenovo alterations.
4. Check inside the server for any obvious unsafe conditions, such as metal filings, contamination, water or other liquid, or signs of fire or smoke damage.
5. Check for worn, frayed, or pinched cables.
6. Make sure that the power-supply cover tighteners (screws or rivets) have not been removed or tampered with.

System reliability guidelines

Review the system reliability guidelines to ensure proper system cooling and reliability.

Make sure the following requirements are met:

- When the system comes with redundant power, a power supply must be installed in each power-supply bay.
- Adequate space around the node and chassis must be spared to allow the cooling system to work properly. Leave approximately 50 mm (2.0 in.) of open space around the front and rear of the chassis. Do not place any object in front of the fans.
- For proper cooling and airflow, refit the node cover before you turn the power on. Do not operate the node with the node cover removed, for it might damage node components.
- Cabling instructions that come with optional components must be followed.
- A removed hot-swap drive must be replaced within two minutes after removal.
- A removed hot-swap power supply must be replaced by another power supply unit or a PSU filler within two minutes after removal.
- All processor sockets must contain either a socket cover or a processor with heat sink.

Handling static-sensitive devices

Review these guidelines before you handle static-sensitive devices to reduce the possibility of damage from electrostatic discharge.

Attention: Prevent exposure to static electricity, which might lead to system halt and loss of data, by keeping static-sensitive components in their static-protective packages until installation, and handling these devices with an electrostatic-discharge wrist strap or other grounding system.

- Limit your movement to prevent building up static electricity around you.
- Take additional care when handling devices during cold weather, for heating would reduce indoor humidity and increase static electricity.
- Always use an electrostatic-discharge wrist strap or other grounding system.
- While the device is still in its static-protective package, touch it to an unpainted metal surface on the outside of the node or chassis for at least two seconds. This drains static electricity from the package and from your body.
- Remove the device from the package and install it directly into the node or chassis without putting it down. If it is necessary to put the device down, put it back into the static-protective package. Never place the device on the node or chassis or on any metal surface.
- When handling a device, carefully hold it by the edges or the frame.
- Do not touch solder joints, pins, or exposed circuitry.
- Keep the device from others' reach to prevent possible damages.

Power on and power off the system

Follow the instructions in this section to power on and power off the system.

Power on the system

After the solution performs a short self-test (power status LED flashes quickly) when connected to input power, it enters a standby state (power status LED flashes once per second).

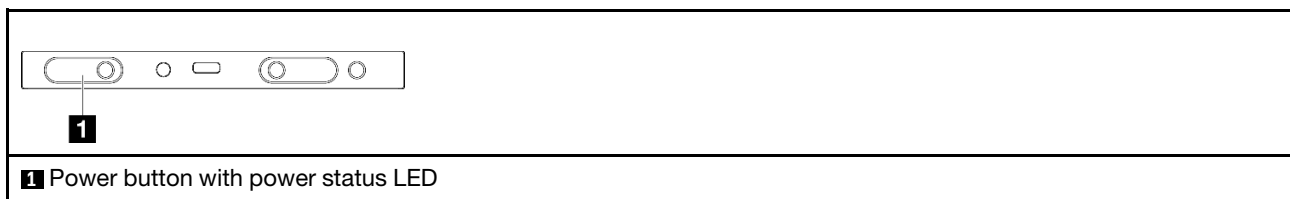

The system can be turned on (power LED on) in any of the following ways:

- You can press the power button.
- The solution can restart automatically after a power interruption.
- The solution can respond to remote power-on requests sent to the Lenovo XClarity Controller.

For information about powering off the solution, see [“Power off the system” on page 16](#).

Power off the system

The system remains in a standby state when it is connected to a power source, allowing the Lenovo XClarity Controller to respond to remote power-on requests. To remove all power from the system (power status LED off), all power cables must be disconnected.



To place the system in a standby state (power status LED flashes once per second):

Note: The Lenovo XClarity Controller can place the system in a standby state as an automatic response to a critical system failure.

- Start an orderly shutdown using the operating system (if supported by your operating system).
- Press the power button to start an orderly shutdown (if supported by your operating system).
- Press and hold the power button for more than 4 seconds to force a shutdown.

When in a standby state, the solution can respond to remote power-on requests sent to the Lenovo XClarity Controller. For information about powering on the solution, see [“Power on the system” on page 16](#).

Chassis replacement

Follow instructions in this section to remove or install the chassis from or to the rack.

Important: For safety, make sure that there is no node or power supply unit installed in the chassis when removing or installing the chassis from or to the rack.

Remove the chassis from the rack

Follow instructions in this section to remove the chassis from the rack.

About this task

To avoid potential danger, make sure to read and follow the safety information.

R006



CAUTION:

Do not place any object on top of a rack-mounted device unless that rack-mounted device is intended for use as a shelf.

Attention:

- Read [“Installation Guidelines” on page 13](#) and [“Safety inspection checklist” on page 14](#) to make sure that you work safely.
- Use safe practices when lifting the chassis. It is advised that the task of removing or installing the chassis be executed by two persons.

CAUTION:

Use safe practices when lifting the chassis.

Procedure

Step 1. Make preparations for this task.

- a. If shipping brackets are installed on the rear of the rack, remove them.
 1. ① Remove the screws that secure the rear brackets.
 2. ② Slide the brackets toward the rear of the rack; then, remove the brackets from the rack and the chassis.

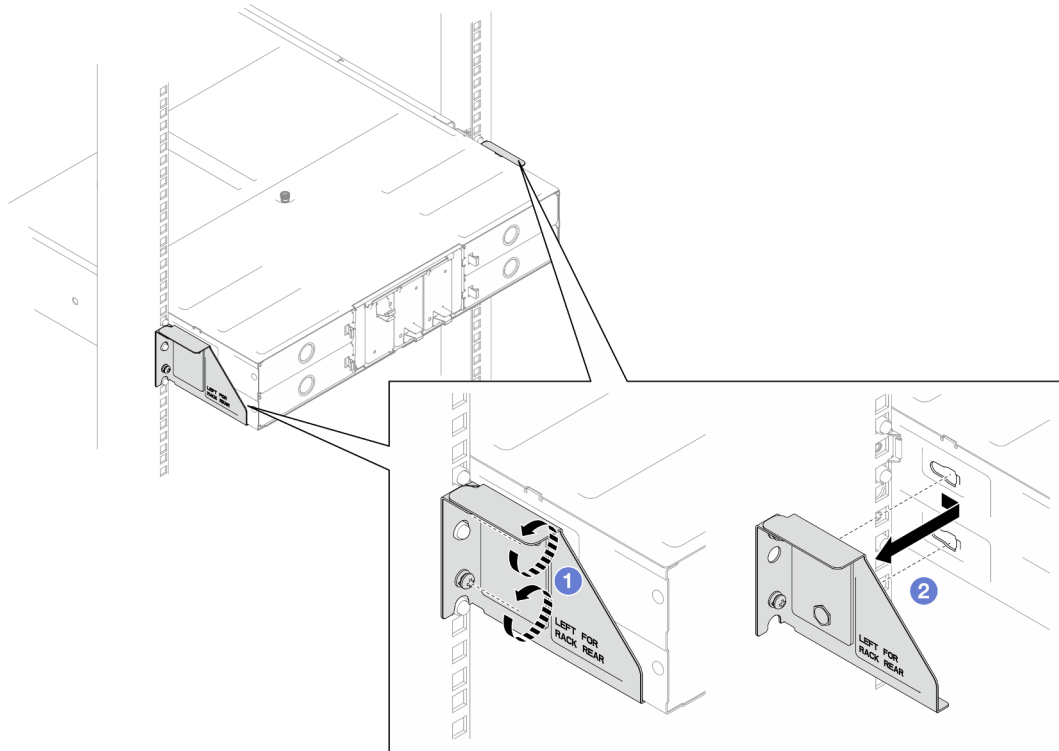

Figure 8. Removal of shipping brackets for 29-inch or 28.31-inch deep racks

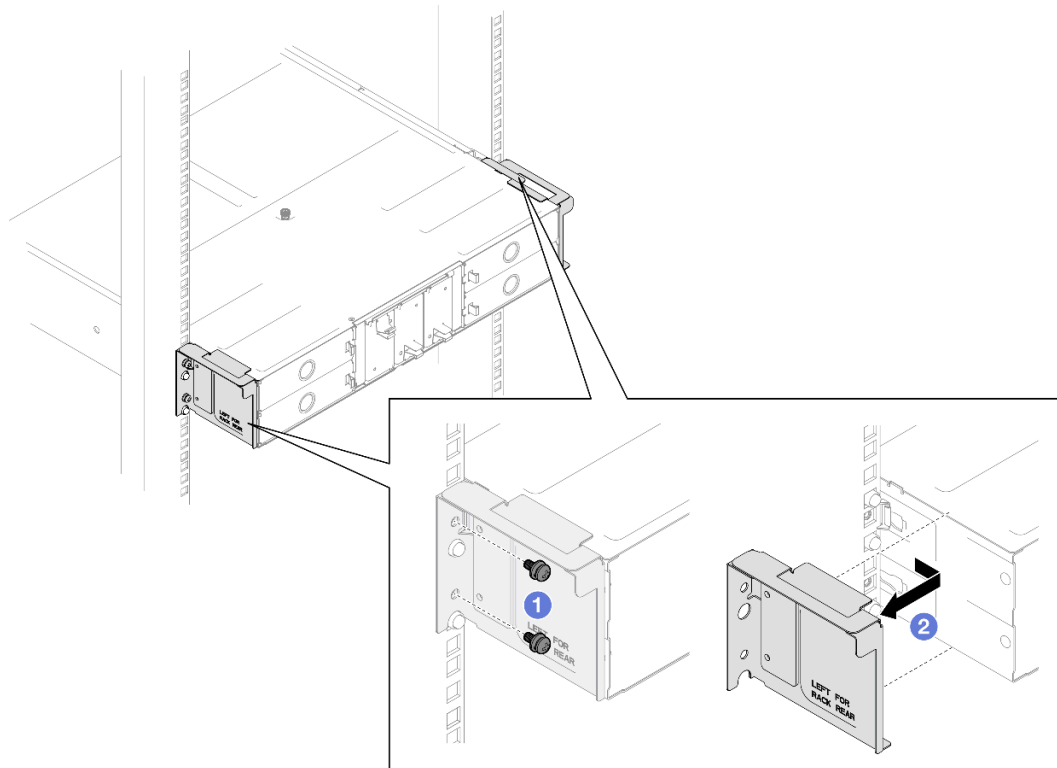

Figure 9. Removal of shipping brackets for 29.5-inch deep racks

- b. If any nodes are installed in the chassis, power off all the nodes and disconnect all external cables from the nodes; then, remove the nodes from the chassis (see “Power off the system” on page 16).

For the procedures of removing a specific node, see the links below:

- **SD520 V4:** https://pubs.lenovo.com/sd520-v4/remove_node_from_chassis

- c. If any power supply units are installed in the chassis, remove them (see “Remove a hot-swap power supply” on page 26).

Step 2. Loosen the captive screws on the front of the chassis.

Step 3. Carefully pull the chassis out of the rack; then, remove the chassis from the rails.

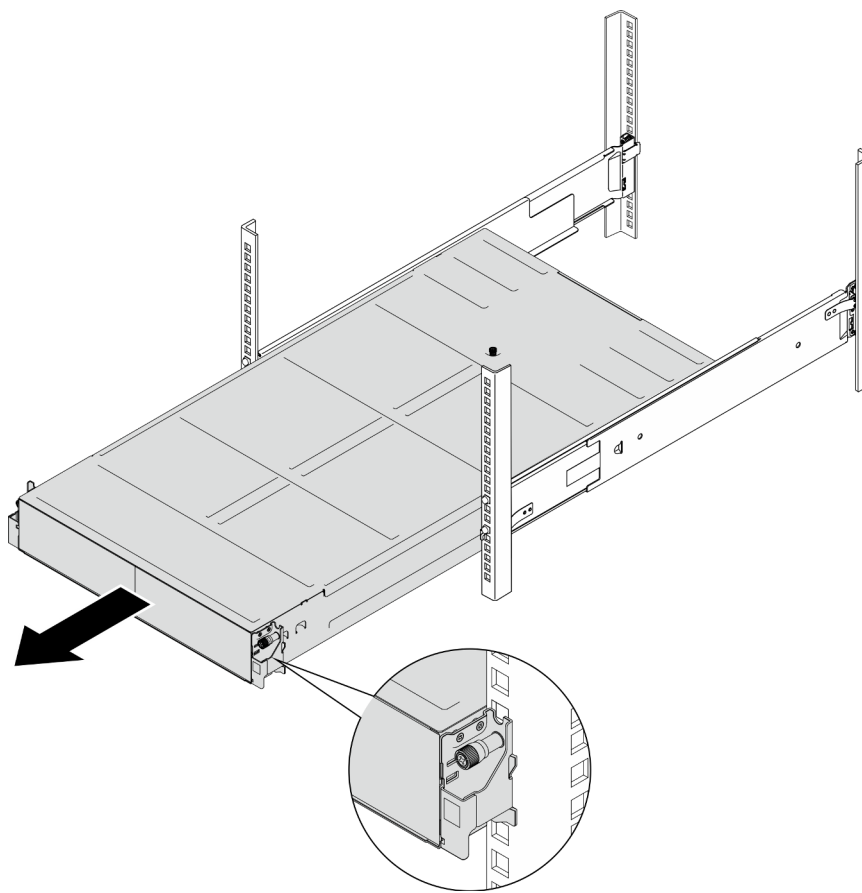

Figure 10. Chassis removal

Step 4. Carefully lay the chassis on a flat, static-protective surface.

After you finish

1. To remove the rails from the rack, follow the instructions below:

https://pubs.lenovo.com/st650-v2/thinksystem_l_shaped_rail_kit.pdf

2. If you are instructed to return the component or optional device, follow all packaging instructions, and use any packaging materials for shipping that are supplied to you.

Demo video

<https://www.youtube.com/watch?v=3yK2cjTXQeA>

Install the chassis to the rack

Follow instructions in this section to install the chassis to the rack.

About this task

To avoid potential danger, make sure to read and follow the safety information.

R006



CAUTION:

Do not place any object on top of a rack-mounted device unless that rack-mounted device is intended for use as a shelf.

Attention:

- Read “[Installation Guidelines](#)” on page 13 and “[Safety inspection checklist](#)” on page 14 to make sure that you work safely.
- To install the rails into a rack, follow the instructions below:

https://pubs.lenovo.com/st650-v2/thinksystem_l_shaped_rail_kit.pdf

After the rails are installed successfully, complete the following steps to install the chassis to the rack.

CAUTION:

Use safe practices when lifting the chassis.

Procedure

Step 1. Make preparations for this task.

- a. If the EIA brackets are not installed to the front of the chassis yet, install them (see “[Install the EIA brackets to the chassis](#)” on page 25).

Step 2. Align the chassis with the rails; then, slide the chassis into the rack.

Step 3. Tighten the captive screws on the front to secure the chassis to the rack.

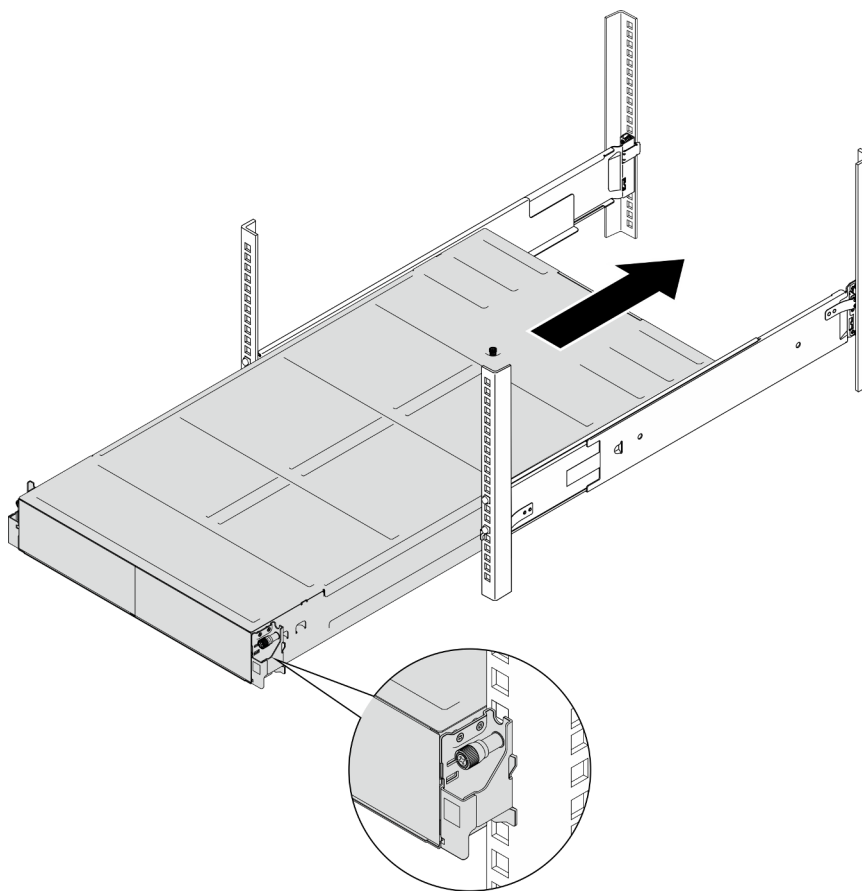

Figure 11. Chassis installation

After you finish

- Reinstall each PSU slot with a PSU or PSU filler (see “Install a hot-swap power supply” on page 29 and [Installation of a PSU filler](#)).
- Reinstall the nodes into the chassis. For the procedures of installing a specific node, see the links below:
 - **SD520 V4:** https://pubs.lenovo.com/sd520-v4/install_a_node_to_chassis
- If the chassis is to be shipped in the cabinet, install shipping brackets on the rear to secure the chassis to the rack.

Note: For reference, the torque required for the screws to be fully tightened/removed is 10.0+/- 0.5 lbf-in, 1.13+/- 0.05 N-M.

Shipping brackets for 29-inch deep racks

1. ① Align the shipping brackets with the guide holes on the rack and the chassis; then, insert the brackets and push it toward the front to engage the brackets in place.
2. ② Tighten the screws to secure the shipping brackets to the chassis and the rack.

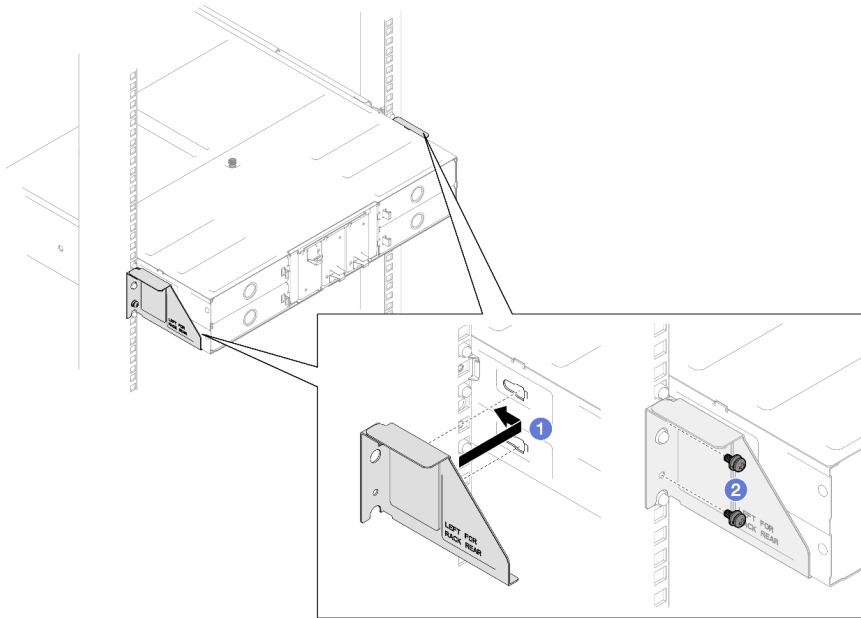

Figure 12. Installation of shipping brackets for 29-inch or 28.31-inch deep racks

Shipping brackets for 29.5-inch deep racks

1. ① Align the shipping brackets with the chassis; then, slide the brackets towards the rack post.
2. ② Tighten the screws to secure the shipping brackets to the rack post.

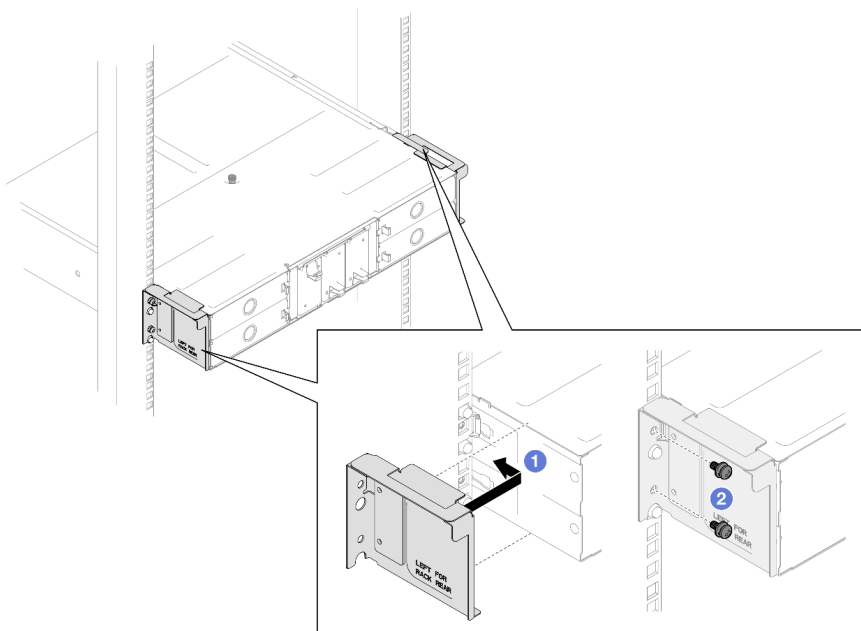

Figure 13. Installation of shipping brackets for 29.5-inch deep racks

Demo video

<https://www.youtube.com/watch?v=aTAsdWTPUF0>

Replace components in the chassis

Follow instructions in this section to remove or install components from or to the chassis.

EIA bracket replacement

Follow instructions in this section to remove or install the EIA brackets from or to the chassis.

Remove the EIA brackets from the chassis

Follow instructions in this section to remove the EIA brackets from the chassis.

About this task

To avoid potential danger, make sure to read and follow the safety information.

Attention:

- Read “[Installation Guidelines](#)” on page 13 and “[Safety inspection checklist](#)” on page 14 to make sure that you work safely.

Procedure

Step 1. Make preparations for this task.

- a. Power off all the nodes (see “[Power off the system](#)” on page 16); then, disconnect all external cables from the nodes.
- b. Remove all the nodes from the chassis.

For the procedures of removing a specific node, see the links below:

- **SD520 V4:** https://pubs.lenovo.com/sd520-v4/remove_node_from_chassis
- c. Remove all power supply units and PSU fillers from the PSU cage (see “[Remove a hot-swap power supply](#)” on page 26 and [Removal of a PSU filler](#)).
 - d. Remove the chassis from the rack (see “[Remove the chassis from the rack](#)” on page 17); then, lay the chassis on a flat, static-protective surface.

Step 2. Remove the left and right EIA brackets from the chassis.

- a. Remove the screws that secure the EIA brackets to the chassis.
- b. Remove the EIA brackets from the chassis.

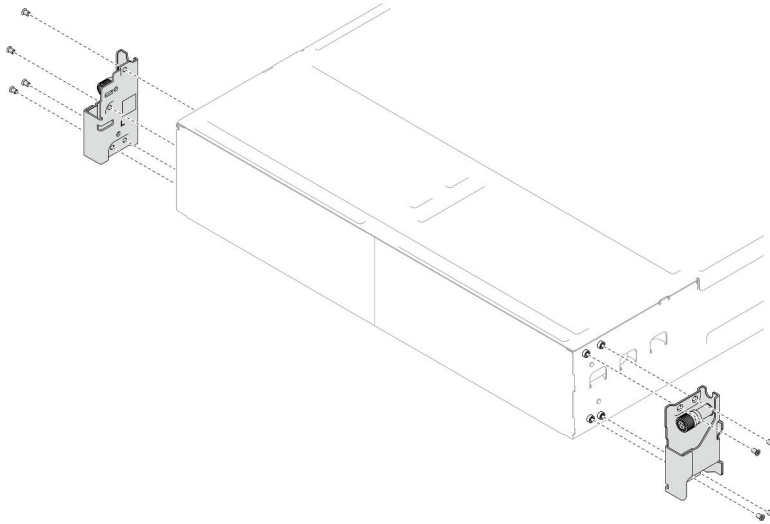

Figure 14. Removal of the EIA brackets

After you finish

1. Install a replacement unit (see “[Install the EIA brackets to the chassis](#)” on page 25).
2. If you are instructed to return the component or optional device, follow all packaging instructions, and use any packaging materials for shipping that are supplied to you.

Demo video

<https://www.youtube.com/watch?v=3yK2cjTXQeA>

Install the EIA brackets to the chassis

Follow instructions in this section to install the EIA brackets to the chassis.

About this task

To avoid potential danger, make sure to read and follow the safety information.

Attention:

- Read “[Installation Guidelines](#)” on page 13 and “[Safety inspection checklist](#)” on page 14 to make sure that you work safely.

Procedure

- Step 1. Align the left EIA bracket with the screw holes on the left of the chassis; then, secure it to the chassis with the screws.
- Step 2. Repeat the same step to secure the right EIA bracket to the right of the chassis.

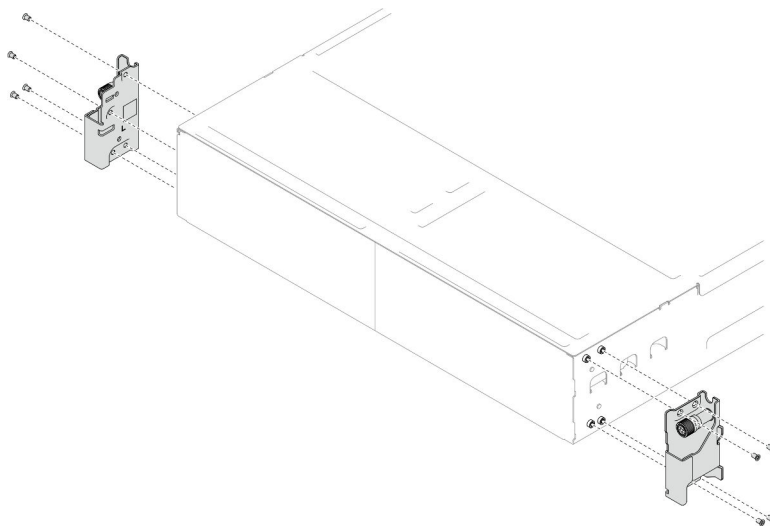

Figure 15. Installation of the EIA brackets

After you finish

- Install the chassis to the rack (see “[Install the chassis to the rack](#)” on page 20).
- Reinstall each PSU slot with a PSU or PSU filler (see “[Install a hot-swap power supply](#)” on page 29 and [Installation of a PSU filler](#)).
- Reinstall the nodes into the chassis. For the procedures of installing a specific node, see the links below:
 - **SD520 V4:** https://pubs.lenovo.com/sd520-v4/install_a_node_to_chassis

Demo video

<https://www.youtube.com/watch?v=aTAsdWTPUF0>

Hot-swap power supply replacement

Follow instructions in this section to remove or install a hot-swap power supply unit (PSU).

Remove a hot-swap power supply

Follow instructions in this section to remove a power supply unit (PSU).

About this task

To avoid potential danger, make sure to read and follow the safety information.

S001



 **DANGER**

Electrical current from power, telephone, and communication cables is hazardous.
To avoid a shock hazard:

- Connect all power cords to a properly wired and grounded electrical outlet/source.
- Connect any equipment that will be attached to this product to properly wired outlets/sources.
- When possible, use one hand only to connect or disconnect signal cables.
- Never turn on any equipment when there is evidence of fire, water, or structural damage.
- The device might have more than one power cord, to remove all electrical current from the device, ensure that all power cords are disconnected from the power source.

S002



CAUTION:

The power-control button on the device and the power switch on the power supply do not turn off the electrical current supplied to the device. The device also might have more than one power cord. To remove all electrical current from the device, ensure that all power cords are disconnected from the power source.

S035



CAUTION:

Never remove the cover on a power supply or any part that has this label attached. Hazardous voltage, current, and energy levels are present inside any component that has this label attached. There are no serviceable parts inside these components. If you suspect a problem with one of these parts, contact a service technician.

Attention:

- Read [“Installation Guidelines” on page 13](#) and [“Safety inspection checklist” on page 14](#) to make sure that you work safely.
- If only one hot-swap power supply is installed in the chassis, the installed nodes must be turned off before the power supply is to be removed.

Procedure

Step 1. Untie the Velcro strap and disconnect the power cord from the power supply unit.

Step 2. Remove the power supply unit.

- 1 Press and hold on the release tab of the power supply unit.
- 2 Hold the handle and pull the power supply unit out of the slot.

Note: PSU with a release tab is a hot-swap PSU. The color of the release tab does not affect the serviceability of the PSU.

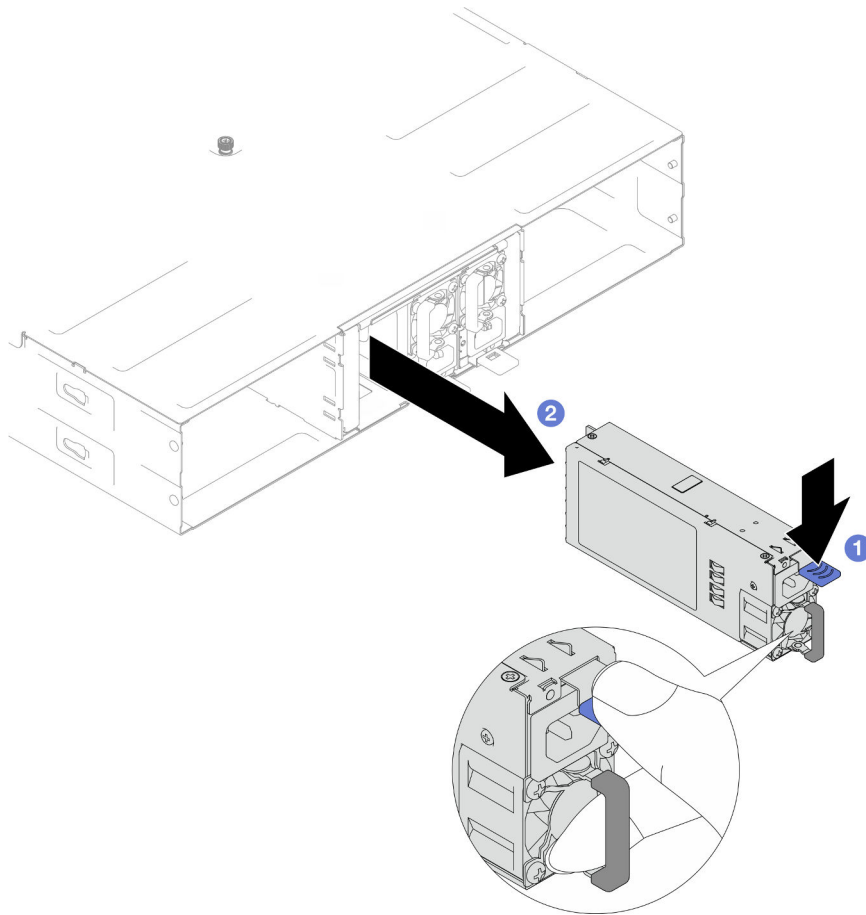

Figure 16. Removal of a hot-swap PSU

After you finish

1. Install a replacement unit or filler (see [“Install a hot-swap power supply” on page 29](#)).

Important:

- A removed hot-swap power supply must be replaced by another power supply unit or a PSU filler within two minutes after removal.
- For PSU slots 2 and 3, the PSU filler must be installed with the tab downward. For PSU slot 1, the filler must be installed with the tab upward.

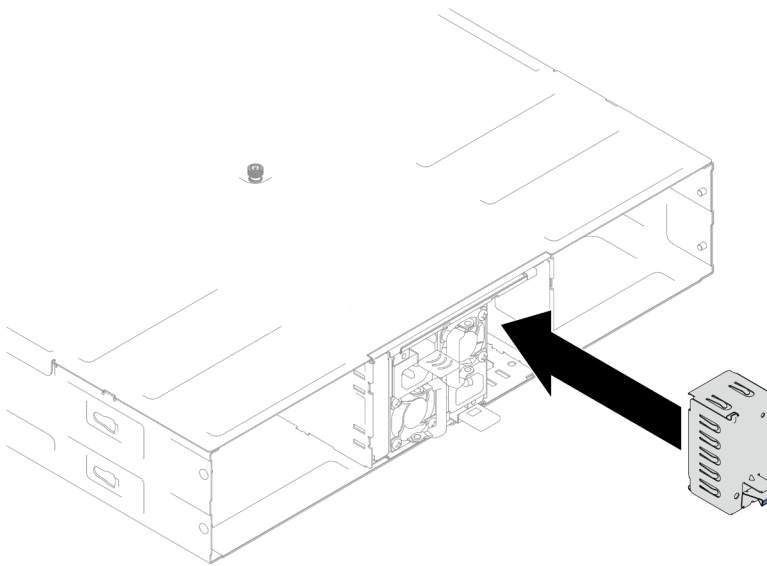

Figure 17. Installation of a PSU filler

2. If you are instructed to return the component or optional device, follow all packaging instructions, and use any packaging materials for shipping that are supplied to you.

Demo video

https://www.youtube.com/watch?v=Veu_2a1x79g

Install a hot-swap power supply

Follow instructions in this section to install a power supply unit (PSU).

About this task

To avoid potential danger, make sure to read and follow the safety information.

S001



 **DANGER**

**Electrical current from power, telephone, and communication cables is hazardous.
To avoid a shock hazard:**

- **Connect all power cords to a properly wired and grounded electrical outlet/source.**
- **Connect any equipment that will be attached to this product to properly wired outlets/sources.**
- **When possible, use one hand only to connect or disconnect signal cables.**
- **Never turn on any equipment when there is evidence of fire, water, or structural damage.**
- **The device might have more than one power cord, to remove all electrical current from the device, ensure that all power cords are disconnected from the power source.**

S035

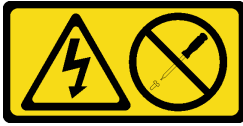

CAUTION:

Never remove the cover on a power supply or any part that has this label attached. Hazardous voltage, current, and energy levels are present inside any component that has this label attached. There are no serviceable parts inside these components. If you suspect a problem with one of these parts, contact a service technician.

CAUTION:



High touch current. Connect to earth before connecting to supply.

Attention:

- Read “[Installation Guidelines](#)” on page 13 and “[Safety inspection checklist](#)” on page 14 to make sure that you work safely.
- The following notes describe the type of power supply that the chassis supports and other information that you must consider when installing a power supply:
 - For redundancy support, an additional hot-swap power supply must be installed, if one is not installed in the chassis.
 - Make sure that the devices that you are installing are supported. For a list of supported optional devices for the chassis, see <https://serverproven.lenovo.com>.

Procedure

Step 1. Make preparations for this task.

- a. Make sure that the power supply unit to be installed is the same as the installed ones. Otherwise, remove all existing power supply units and replace them all with the same power supply units.

Notes:

- CRPS power supply units in the chassis must have the same vendor, wattage, and part number (or alternate part number).
 - CRPS Premium (CFFv5) power supply units in the chassis must have the same wattage, and part number (or alternate part number).
 - PSU with a release tab is a hot-swap PSU. The color of the release tab does not affect the serviceability of the PSU.
- b. If a PSU filler is installed in the PSU slot, remove it.
 1. ① Press and hold the tab on the PSU filler.
 2. ② Pull the filler out of the PSU slot.

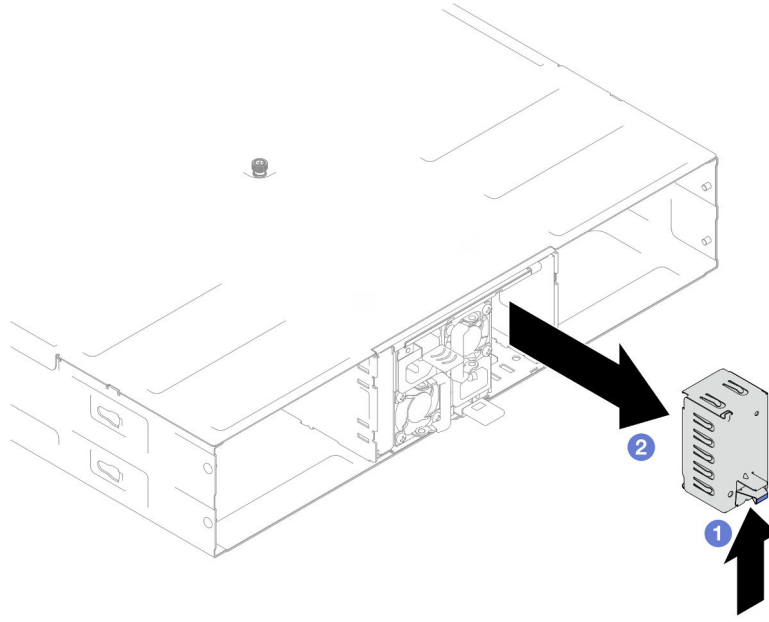

Figure 18. Removal of a PSU filler

- c. If more than one power supply units are to be installed, start with the lowest available PSU slot number.

Step 2. Insert the hot-swap power supply into the slot until the release tab clicks into place.

Important:

- During normal operation, each power-supply slot must contain either a power supply or power-supply filler for proper cooling.
- Make sure to follow the instruction on the guiding label in each slot. For slot 1, the power supply unit must be installed with the fan downward; for slots 2 and 3, the power supply units must be installed with the fan upward.
- After docking the power supply, hold the handle and slightly pull the power supply to make sure that it is securely engaged and cannot be pulled out.

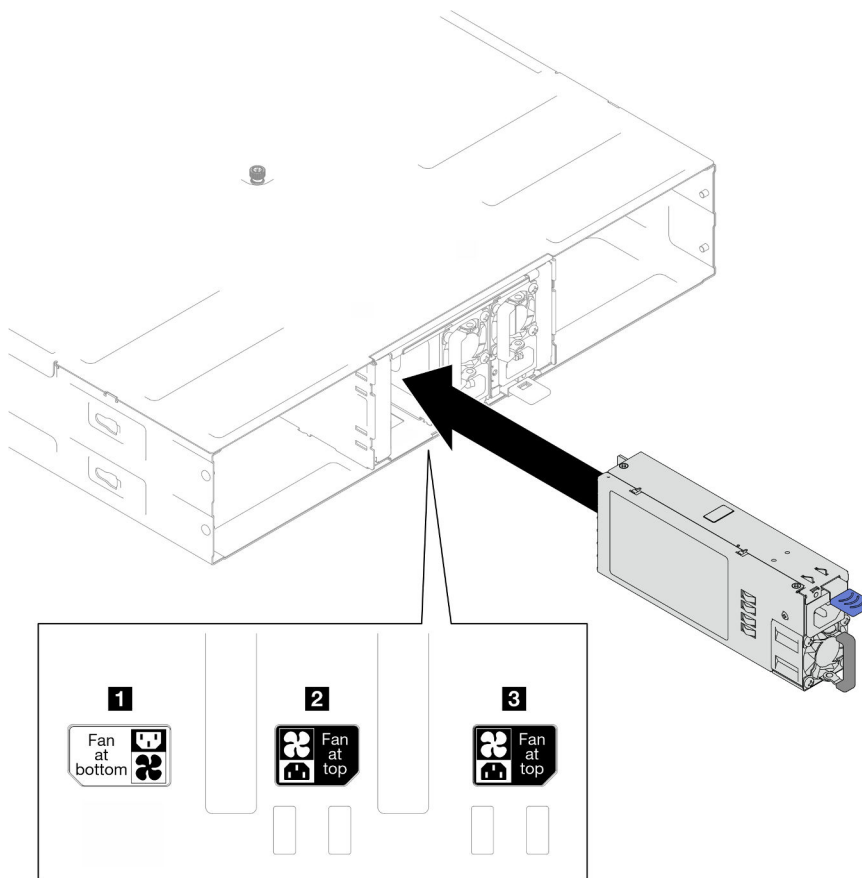

Figure 19. Installation of a hot-swap power supply

- Step 3. Connect one end of the power cord to the AC connector on the back of the new power supply; then, connect the other end of the power cord to a properly grounded electrical outlet.
- Step 4. Make sure the power supply unit handle is perpendicular to the power supply unit; then, tie the power cord to the handle with the pre-attached strap as shown below.

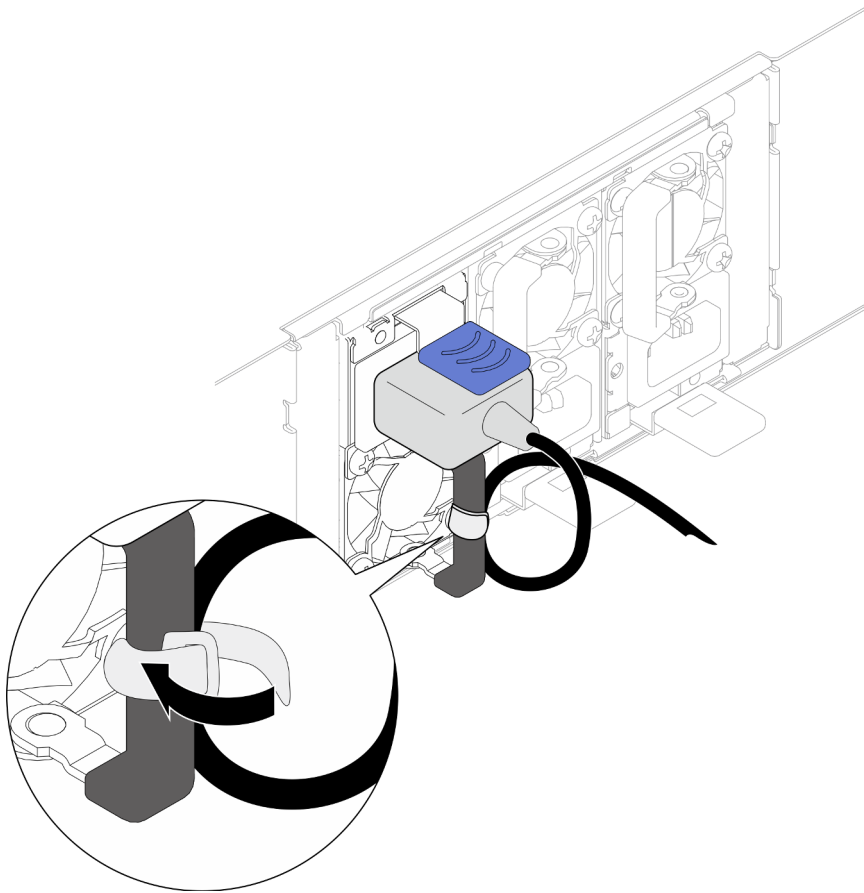

Figure 20. Routing and tying power cord

After you finish

Make sure that the power LED on the power supply is lit, indicating that the power supply is operating correctly.

Demo video

<https://www.youtube.com/watch?v=uPvhuBCt8mw>

PSU cage and chassis midplane replacement

Follow instructions in this section to remove or install the PSU cage and the chassis midplane.

Remove the PSU cage

Follow instructions in this section to remove the PSU cage.

About this task

To avoid potential danger, make sure to read and follow the safety information.

S001



 **DANGER**

Electrical current from power, telephone, and communication cables is hazardous.
To avoid a shock hazard:

- Connect all power cords to a properly wired and grounded electrical outlet/source.
- Connect any equipment that will be attached to this product to properly wired outlets/sources.
- When possible, use one hand only to connect or disconnect signal cables.
- Never turn on any equipment when there is evidence of fire, water, or structural damage.
- The device might have more than one power cord, to remove all electrical current from the device, ensure that all power cords are disconnected from the power source.

S002

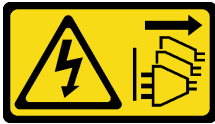

CAUTION:

The power-control button on the device and the power switch on the power supply do not turn off the electrical current supplied to the device. The device also might have more than one power cord. To remove all electrical current from the device, ensure that all power cords are disconnected from the power source.

S035



CAUTION:

Never remove the cover on a power supply or any part that has this label attached. Hazardous voltage, current, and energy levels are present inside any component that has this label attached. There are no serviceable parts inside these components. If you suspect a problem with one of these parts, contact a service technician.

CAUTION:



High touch current. Connect to earth before connecting to supply.

Attention:

- Read “Installation Guidelines” on page 13 and “Safety inspection checklist” on page 14 to make sure that you work safely.

Procedure

Step 1. Make preparations for this task.

- a. Power off all the nodes (see “Power off the system” on page 16); then, disconnect all external cables from the nodes.
- b. Remove all the nodes from the chassis.

For the procedures of removing a specific node, see the links below:

- **SD520 V4:** https://pubs.lenovo.com/sd520-v4/remove_node_from_chassis
- c. Remove all power supply units and PSU fillers from the PSU cage (see “Remove a hot-swap power supply” on page 26 and Removal of a PSU filler).
 - d. Remove the chassis from the rack (see “Remove the chassis from the rack” on page 17); then, lay the chassis on a flat, static-protective surface.

Step 2. Remove the PSU cage from the chassis.

- a. Loosen the thumbscrew located on the top of the chassis.
- b. Hold the vertical partitions between the PSU slots; then, pull the PSU cage out of the chassis.

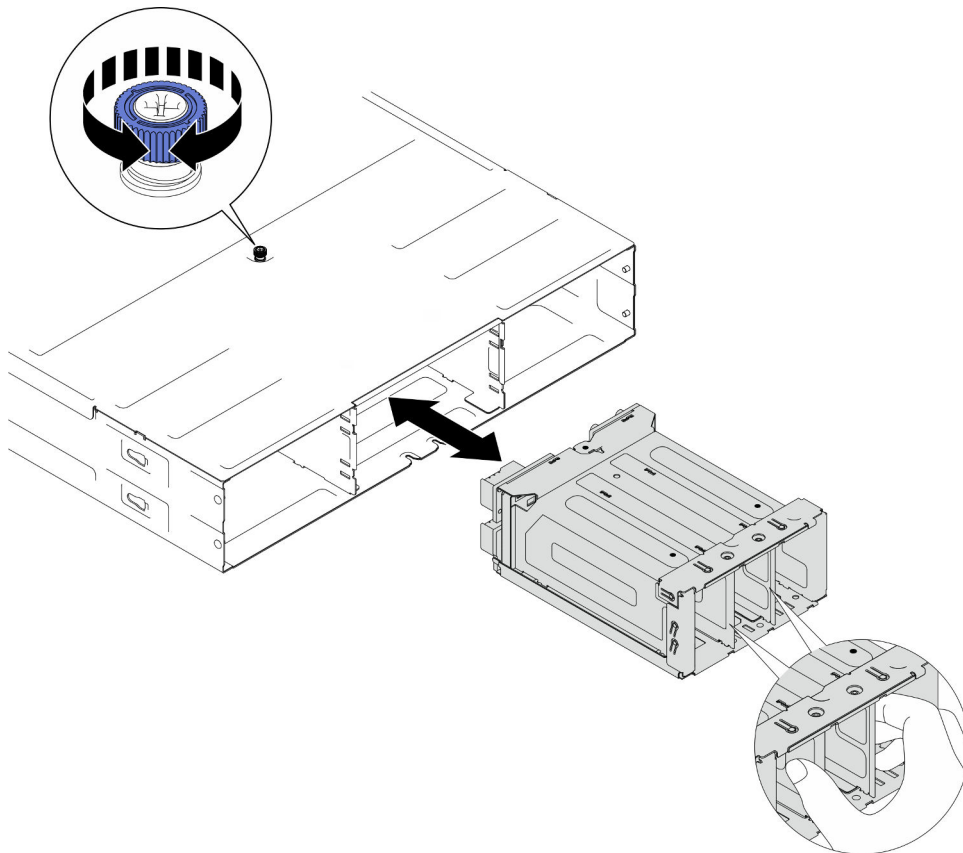

Figure 21. Removal of the PSU cage

Step 3. Carefully lay the PSU cage on a flat, static-protective surface.

After you finish

1. Install a replacement unit (see [“Install a PSU cage” on page 39](#)).
2. If you are instructed to return the component or optional device, follow all packaging instructions, and use any packaging materials for shipping that are supplied to you.

Demo video

https://www.youtube.com/watch?v=fpsEcN_KA4Q

Remove the chassis midplane

Follow instructions in this section to remove the chassis midplane.

About this task

To avoid potential danger, make sure to read and follow the safety information.

S002



CAUTION:

The power-control button on the device and the power switch on the power supply do not turn off the electrical current supplied to the device. The device also might have more than one power cord. To remove all electrical current from the device, ensure that all power cords are disconnected from the power source.

Attention:

- Read [“Installation Guidelines” on page 13](#) and [“Safety inspection checklist” on page 14](#) to make sure that you work safely.
- Power off all the nodes in the chassis; then, disconnect all the power cords from the installed power supply units.

Procedure

Step 1. Make preparations for this task.

- a. Power off all the nodes (see [“Power off the system” on page 16](#)); then, disconnect all external cables from the nodes.
- b. Remove all the nodes from the chassis.

For the procedures of removing a specific node, see the links below:

- **SD520 V4:** https://pubs.lenovo.com/sd520-v4/remove_node_from_chassis
- c. Remove all power supply units and PSU fillers from the PSU cage (see [“Remove a hot-swap power supply” on page 26](#) and [Removal of a PSU filler](#)).
 - d. Remove the chassis from the rack (see [“Remove the chassis from the rack” on page 17](#)); then, lay the chassis on a flat, static-protective surface.
 - e. Remove the PSU cage from the chassis (see [“Remove the PSU cage” on page 33](#)); then, carefully lay the PSU cage on a flat, static-protective surface, orienting the midplane upward.

Step 2. Loosen the six screws that secure the chassis midplane to the PSU cage.

Step 3. Lift the chassis midplane away from the PSU cage.

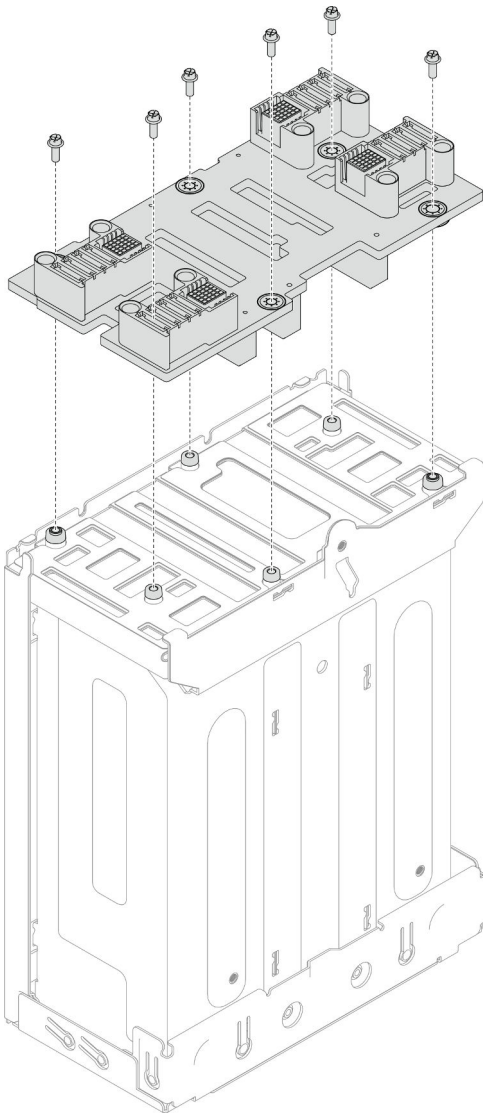

Figure 22. Removal of the chassis midplane

After you finish

1. Install a replacement unit (see “[Install the chassis midplane](#)” on page 37).
2. If you are instructed to return the component or optional device, follow all packaging instructions, and use any packaging materials for shipping that are supplied to you.

Demo video

<https://www.youtube.com/watch?v=tl88mbxQAqk>

Install the chassis midplane

Follow instructions in this section to install the chassis midplane.

About this task

To avoid potential danger, make sure to read and follow the safety information.

S002



CAUTION:

The power-control button on the device and the power switch on the power supply do not turn off the electrical current supplied to the device. The device also might have more than one power cord. To remove all electrical current from the device, ensure that all power cords are disconnected from the power source.

Attention:

- Read “Installation Guidelines” on page 13 and “Safety inspection checklist” on page 14 to make sure that you work safely.
- Prevent exposure to static electricity, which might lead to system halt and loss of data, by keeping static-sensitive components in their static-protective packages until installation, and handling these devices with an electrostatic-discharge wrist strap or other grounding system.

Notes:

- The firmware of the chassis midplane can be updated via Lenovo XClarity Controller (XCC) and Lenovo XClarity Essentials OneCLI (LXCE OneCLI). **Only the caretaker node can perform this update.**
- By default, the **caretaker node** is automatically selected by the PSoC firmware on the chassis midplane. To change the chassis caretaker preference, see https://pubs.lenovo.com/xcc3/NN1ia_c_d3_chassis.
- Go to [Chapter 6 “Update the firmware” on page 43](#) for more information on firmware updating tools.

Procedure

- Step 1. Align the chassis midplane with the screw holes and edges of the PSU cage; then, place the midplane onto the PSU cage.
- Step 2. Tighten the six screws to secure the chassis midplane to the PSU cage.

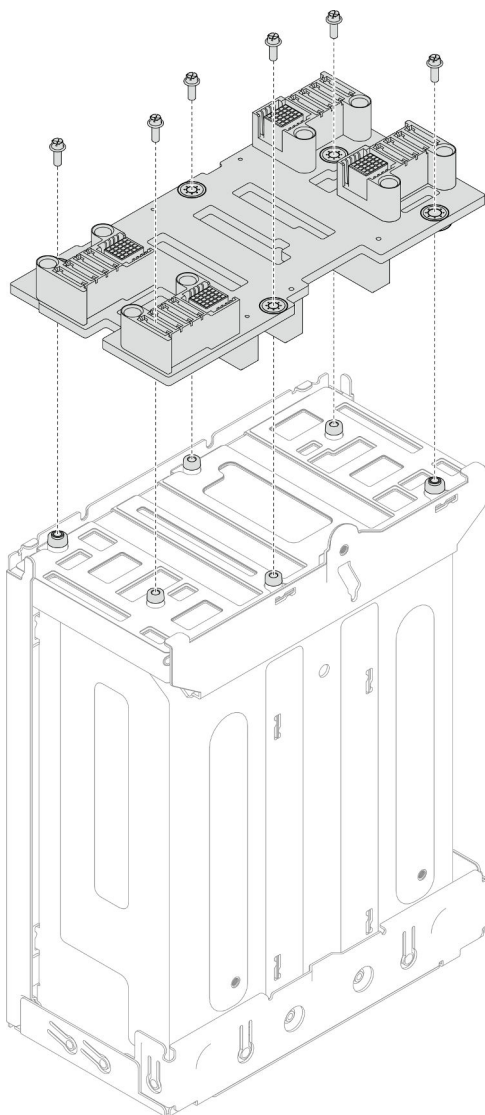

Figure 23. Installation of the chassis midplane

After you finish

1. Reinstall the PSU cage to the chassis (see “Install a PSU cage” on page 39).
2. Install the chassis to the rack (see “Install the chassis to the rack” on page 20).
3. Reinstall the nodes into the chassis. For the procedures of installing a specific node, see the links below:
 - **SD520 V4:** https://pubs.lenovo.com/sd520-v4/install_a_node_to_chassis
4. Reinstall each PSU slot with a PSU or PSU filler (see “Install a hot-swap power supply” on page 29 and [Installation of a PSU filler](#)).

Demo video

<https://www.youtube.com/watch?v=gElqsboo8os>

Install a PSU cage

Follow instructions in this section to install a PSU cage.

About this task

To avoid potential danger, make sure to read and follow the safety information.

S001



DANGER

**Electrical current from power, telephone, and communication cables is hazardous.
To avoid a shock hazard:**

- Connect all power cords to a properly wired and grounded electrical outlet/source.
- Connect any equipment that will be attached to this product to properly wired outlets/sources.
- When possible, use one hand only to connect or disconnect signal cables.
- Never turn on any equipment when there is evidence of fire, water, or structural damage.
- The device might have more than one power cord, to remove all electrical current from the device, ensure that all power cords are disconnected from the power source.

S035



CAUTION:

Never remove the cover on a power supply or any part that has this label attached. Hazardous voltage, current, and energy levels are present inside any component that has this label attached. There are no serviceable parts inside these components. If you suspect a problem with one of these parts, contact a service technician.

CAUTION:



High touch current. Connect to earth before connecting to supply.

Attention:

- Read [“Installation Guidelines” on page 13](#) and [“Safety inspection checklist” on page 14](#) to make sure that you work safely.
- Prevent exposure to static electricity, which might lead to system halt and loss of data, by keeping static-sensitive components in their static-protective packages until installation, and handling these devices with an electrostatic-discharge wrist strap or other grounding system.

Procedure

- Step 1. Insert the PSU cage into the chassis until it stops.
- Step 2. Tighten the thumbscrew located on the top of the chassis.

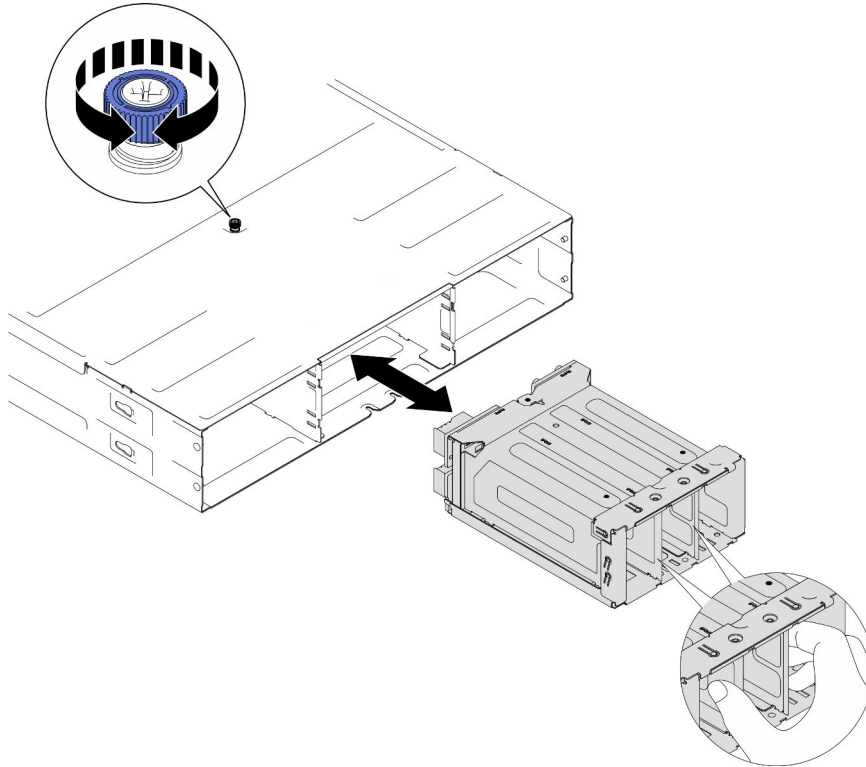

Figure 24. Installation of the PSU cage

After you finish

1. Install the chassis to the rack (see “[Install the chassis to the rack](#)” on page 20).
2. Reinstall the nodes into the chassis. For the procedures of installing a specific node, see the links below:
 - **SD520 V4:** https://pubs.lenovo.com/sd520-v4/install_a_node_to_chassis
3. Reinstall each PSU slot with a PSU or PSU filler (see “[Install a hot-swap power supply](#)” on page 29 and [Installation of a PSU filler](#)).

Demo video

<https://www.youtube.com/watch?v=RXenXuPc-JA>

Chapter 6. Update the firmware

Several options are available to update the firmware for the system.

The tools listed here can be used to update the most current firmware for the chassis, nodes, and the devices that are installed in the system.

- Best practices related to updating firmware is available at the following site:
 - <https://lenovopress.lenovo.com/lp0656-lenovo-thinksystem-firmware-and-driver-update-best-practices>
- Product notification can be subscribed at the following site for the latest firmware updates:
 - <https://datacentersupport.lenovo.com/solutions/ht509500>

Update Bundles (Service Packs)

Lenovo typically releases firmware in bundles called Update Bundles (Service Packs). To ensure that all of the firmware updates are compatible, you should update all firmware at the same time. If you are updating firmware for both the Lenovo XClarity Controller and UEFI, update the firmware for Lenovo XClarity Controller first.

Update method terminology

- **In-band update.** The installation or update is performed using a tool or application within an operating system that is executing on the server's core CPU.
- **Out-of-band update.** The installation or update is performed by the Lenovo XClarity Controller collecting the update and then directing the update to the target subsystem or device. Out-of-band updates have no dependency on an operating system executing on the core CPU. However, most out-of-band operations do require the server to be in the S0 (Working) power state.
- **On-Target update.** The installation or update is initiated from an installed operating system executing on the target server itself.
- **Off-Target update.** The installation or update is initiated from a computing device interacting directly with the server's Lenovo XClarity Controller.
- **Update Bundles (Service Packs).** Update Bundles (Service Packs) are bundled updates designed and tested to provide the interdependent level of functionality, performance, and compatibility. Update Bundles (Service Packs) are server machine-type specific and are built (with firmware and device driver updates) to support specific Windows Server, Red Hat Enterprise Linux (RHEL) and SUSE Linux Enterprise Server (SLES) operating system distributions. Machine-type-specific firmware-only Update Bundles (Service Packs) are also available.

Firmware updating tools

See the following table to determine the best Lenovo tool to use for installing and setting up the firmware:

Tool	Update Methods Supported	Core System Firmware Updates	I/O Devices Firmware Updates	Drive Firmware Updates	Graphical user interface	Command line interface	Supports Static Bundles (Service Packs)	Chassis Mid-plane PSoC Firmware Update
Lenovo XClarity Provisioning Manager (LXPM)	In-band ² On-Target	✓			✓			
Lenovo XClarity Controller (XCC)	In-band ⁴ Out-of-band Off-Target	✓	Selected I/O devices	✓ ³	✓		✓	✓
Lenovo XClarity Essentials OneCLI (OneCLI)	In-band Out-of-band On-Target Off-Target	✓	All I/O devices	✓ ³		✓	✓	✓
Lenovo XClarity Essentials UpdateXpress (LXCE)	In-band Out-of-band On-Target Off-Target	✓	All I/O devices		✓		✓	
Lenovo XClarity Essentials Bootable Media Creator (BoMC)	In-band Out-of-band Off-Target	✓	All I/O devices		✓ (BoMC application)	✓ (BoMC application)	✓	
Lenovo XClarity Administrator (LXCA)	In-band ¹ Out-of-band ² Off-Target	✓	All I/O devices	✓	✓		✓	

Tool	Update Methods Supported	Core System Firmware Updates	I/O Devices Firmware Updates	Drive Firmware Updates	Graphical user interface	Command line interface	Supports Static Bundles (Service Packs)	Chassis Mid-plane PSoC Firmware Update
Lenovo XClarity Integrator (LXCI) for VMware vCenter	Out-of-band Off-Target	√	Selected I/O devices		√			
Lenovo XClarity Integrator (LXCI) for Microsoft Windows Admin Center	In-band Out-of-band On-Target Off-Target	√	All I/O devices		√		√	
Notes:								
<ol style="list-style-type: none"> For I/O firmware updates. For BMC and UEFI firmware updates. Drive firmware update is only supported by the tools and methods below: <ul style="list-style-type: none"> XCC Bare Metal Update (BMU): In-band, and requires system reboot. Lenovo XClarity Essentials OneCLI: In-band, and does not require system reboot. Bare Metal Update (BMU) only. 								

- **Lenovo XClarity Provisioning Manager**

From Lenovo XClarity Provisioning Manager, you can update the Lenovo XClarity Controller firmware, the UEFI firmware, and the Lenovo XClarity Provisioning Manager software.

Note: By default, the Lenovo XClarity Provisioning Manager Graphical User Interface is displayed when you start the server and press the key specified in the on-screen instructions. If you have changed that default to be the text-based system setup, you can bring up the Graphical User Interface from the text-based system setup interface.

For additional information about using Lenovo XClarity Provisioning Manager to update firmware, see:

“Firmware Update” section in the LXPM documentation compatible with your server at <https://pubs.lenovo.com/lxpm-overview/>

- **Lenovo XClarity Controller**

If you need to install a specific update, you can use the Lenovo XClarity Controller interface for a specific server.

Notes:

- To perform an in-band update through Windows or Linux, the operating system driver must be installed and the Ethernet-over-USB (sometimes called LAN over USB) interface must be enabled.

For additional information about configuring Ethernet over USB, see:

“Configuring Ethernet over USB” section in the XCC documentation version compatible with your server at <https://pubs.lenovo.com/lxcc-overview/>

- If you update firmware through the Lenovo XClarity Controller, make sure that you have downloaded and installed the latest device drivers for the operating system that is running on the server.

For additional information about using Lenovo XClarity Controller to update firmware, see:

“Updating Server Firmware” section in the XCC documentation compatible with your server at <https://pubs.lenovo.com/lxcc-overview/>

- **Lenovo XClarity Essentials OneCLI**

Lenovo XClarity Essentials OneCLI is a collection of command line applications that can be used to manage Lenovo servers. Its update application can be used to update firmware and device drivers for your servers. The update can be performed within the host operating system of the server (in-band) or remotely through the BMC of the server (out-of-band).

For additional information about using Lenovo XClarity Essentials OneCLI to update firmware, see:

https://pubs.lenovo.com/lxce-onecli/onecli_c_update

- **Lenovo XClarity Essentials UpdateXpress**

Lenovo XClarity Essentials UpdateXpress provides most of OneCLI update functions through a graphical user interface (GUI). It can be used to acquire and deploy Static Bundle update packages and individual updates. Static Bundle contain firmware and device driver updates for Microsoft Windows and for Linux.

You can obtain Lenovo XClarity Essentials UpdateXpress from the following location:

<https://datacentersupport.lenovo.com/solutions/Invo-xpress>

- **Lenovo XClarity Essentials Bootable Media Creator**

You can use Lenovo XClarity Essentials Bootable Media Creator to create bootable media that is suitable for firmware updates, VPD updates, inventory and FFDC collection, advanced system configuration, FoD Keys management, secure erase, RAID configuration, and diagnostics on supported servers.

You can obtain Lenovo XClarity Essentials BoMC from the following location:

<https://datacentersupport.lenovo.com/solutions/Invo-bomc>

- **Lenovo XClarity Administrator**

If you are managing multiple servers using the Lenovo XClarity Administrator, you can update firmware for all managed servers through that interface. Firmware management is simplified by assigning firmware-compliance policies to managed endpoints. When you create and assign a compliance policy to managed endpoints, Lenovo XClarity Administrator monitors changes to the inventory for those endpoints and flags any endpoints that are out of compliance.

For additional information about using Lenovo XClarity Administrator to update firmware, see:

https://pubs.lenovo.com/lxca/update_fw

- **Lenovo XClarity Integrator offerings**

Lenovo XClarity Integrator offerings can integrate management features of Lenovo XClarity Administrator and your server with software used in a certain deployment infrastructure, such as VMware vCenter, Microsoft Admin Center, or Microsoft System Center.

For additional information about using Lenovo XClarity Integrator to update firmware, see:

<https://pubs.lenovo.com/lxci-overview/>

Appendix A. Hardware disassembling for recycle

Follow instructions in this section to recycle components with compliance with local laws or regulations.

Disassemble the chassis for recycle

Follow instructions in this section to disassemble the chassis before recycling.

About this task

Attention:

- Read “[Installation Guidelines](#)” on page 13 and “[Safety inspection checklist](#)” on page 14 to make sure that you work safely.

Step 1. Power off all the nodes (see “[Power off the system](#)” on page 16); then, disconnect all external cables from the nodes.

Step 2. Remove all the nodes from the chassis.

For the procedures of removing a specific node, see the links below:

- **SD520 V4:** https://pubs.lenovo.com/sd520-v4/remove_node_from_chassis
- Step 3. Remove all power supply units and PSU fillers from the PSU cage (see “[Remove a hot-swap power supply](#)” on page 26 and [Removal of a PSU filler](#)).
- Step 4. Remove the chassis from the rack (see “[Remove the chassis from the rack](#)” on page 17); then, lay the chassis on a flat, static-protective surface.
- Step 5. Remove the PSU cage from the chassis (see “[Remove the PSU cage](#)” on page 33).
- Step 6. Remove the chassis midplane from the PSU cage (see “[Remove the chassis midplane](#)” on page 36).
- Step 7. Remove the left and right EIA brackets from the chassis (see “[Remove the EIA brackets from the chassis](#)” on page 24).

After disassembling the chassis, recycle the units in compliance with local regulations.

Appendix B. Getting help and technical assistance

If you need help, service, or technical assistance or just want more information about Lenovo products, you will find a wide variety of sources available from Lenovo to assist you.

On the World Wide Web, up-to-date information about Lenovo systems, optional devices, services, and support are available at:

<http://datacentersupport.lenovo.com>

Note: IBM is Lenovo's preferred service provider for ThinkSystem.

Collecting service data

To clearly identify the root cause of a server issue or at the request of Lenovo Support, you might need collect service data that can be used for further analysis. Service data includes information such as event logs and hardware inventory.

Service data can be collected through the following tools:

- **Lenovo XClarity Provisioning Manager**

Use the Collect Service Data function of Lenovo XClarity Provisioning Manager to collect system service data. You can collect existing system log data or run a new diagnostic to collect new data.

- **Lenovo XClarity Controller**

You can use the Lenovo XClarity Controller web interface or the CLI to collect service data for the server. The file can be saved and sent to Lenovo Support.

- For more information about using the web interface to collect service data, see the “Backing up the BMC configuration” section in the XCC documentation compatible with your server at <https://pubs.lenovo.com/lxcc-overview/>.
- For more information about using the CLI to collect service data, see the “XCC `service_log` command” section in the XCC documentation compatible with your server at <https://pubs.lenovo.com/lxcc-overview/>.

- **Lenovo XClarity Administrator**

Lenovo XClarity Administrator can be set up to collect and send diagnostic files automatically to Lenovo Support when certain serviceable events occur in Lenovo XClarity Administrator and the managed endpoints. You can choose to send diagnostic files to Lenovo Support using Call Home or to another service provider using SFTP. You can also manually collect diagnostic files, open a problem record, and send diagnostic files to the Lenovo Support.

You can find more information about setting up automatic problem notification within the Lenovo XClarity Administrator at https://pubs.lenovo.com/lxca/admin_setupcallhome.

- **Lenovo XClarity Essentials OneCLI**

Lenovo XClarity Essentials OneCLI has inventory application to collect service data. It can run both in-band and out-of-band. When running in-band within the host operating system on the server, OneCLI can collect information about the operating system, such as the operating system event log, in addition to the hardware service data.

To obtain service data, you can run the `getinfor` command. For more information about running the `getinfor`, see https://pubs.lenovo.com/lxce-onecli/onecli_r_getinfor_command.

Contacting Support

You can contact Support to obtain help for your issue.

You can receive hardware service through a Lenovo Authorized Service Provider. To locate a service provider authorized by Lenovo to provide warranty service, go to <https://datacentersupport.lenovo.com/serviceprovider> and use filter searching for different countries. For Lenovo support telephone numbers, see <https://datacentersupport.lenovo.com/supportphonenumberlist> for your region support details.

Appendix C. Documents and supports

This section provides handy documents, driver and firmware downloads, and support resources.

Documents download

This section provides introduction and download link for handy documents.

Documents

Download the following product documentations at:

https://pubs.lenovo.com/d3-v2-chassis/pdf_files

- **Rail Installation Guides**

- Rail installation in a rack

https://pubs.lenovo.com/st650-v2/thinksystem_l_shaped_rail_kit.pdf

- **User Guide**

- Complete overview and hardware components replacing.

Support websites

This section provides driver and firmware downloads and support resources.

Support and downloads

- Lenovo Data Center Forum
 - https://forums.lenovo.com/t5/Datacenter-Systems/ct-p/sv_eg
- Lenovo License Information Documents
 - <https://datacentersupport.lenovo.com/documents/Invo-eula>
- Lenovo Press website (Product Guides/Datasheets/White papers)
 - <https://lenovopress.lenovo.com/>
- Lenovo Privacy Statement
 - <https://www.lenovo.com/privacy>
- Lenovo Product Security Advisories
 - https://datacentersupport.lenovo.com/product_security/home
- Lenovo Product Warranty Plans
 - <http://datacentersupport.lenovo.com/warrantylookup>
- Lenovo Server Operating Systems Support Center website
 - <https://datacentersupport.lenovo.com/solutions/server-os>
- Lenovo ServerProven website (Options compatibility lookup)
 - <https://serverproven.lenovo.com>
- Operating System Installation Instructions
 - <https://pubs.lenovo.com/thinksystem#os-installation>

- Submit an eTicket (service request)
 - <https://support.lenovo.com/servicerequest>
- Subscribe to Lenovo Data Center Group product notifications (Stay up to date on firmware updates)
 - <https://datacentersupport.lenovo.com/solutions/ht509500>

Appendix D. Notices

Lenovo may not offer the products, services, or features discussed in this document in all countries. Consult your local Lenovo representative for information on the products and services currently available in your area.

Any reference to a Lenovo product, program, or service is not intended to state or imply that only that Lenovo product, program, or service may be used. Any functionally equivalent product, program, or service that does not infringe any Lenovo intellectual property right may be used instead. However, it is the user's responsibility to evaluate and verify the operation of any other product, program, or service.

Lenovo may have patents or pending patent applications covering subject matter described in this document. The furnishing of this document is not an offer and does not provide a license under any patents or patent applications. You can send inquiries in writing to the following:

*Lenovo (United States), Inc.
1009 Think Place
Morrisville, NC 27560
U.S.A.
Attention: Lenovo VP of Intellectual Property*

LENOVO PROVIDES THIS PUBLICATION "AS IS" WITHOUT WARRANTY OF ANY KIND, EITHER EXPRESS OR IMPLIED, INCLUDING, BUT NOT LIMITED TO, THE IMPLIED WARRANTIES OF NON-INFRINGEMENT, MERCHANTABILITY OR FITNESS FOR A PARTICULAR PURPOSE. Some jurisdictions do not allow disclaimer of express or implied warranties in certain transactions, therefore, this statement may not apply to you.

This information could include technical inaccuracies or typographical errors. Changes are periodically made to the information herein; these changes will be incorporated in new editions of the publication. Lenovo may make improvements and/or changes in the product(s) and/or the program(s) described in this publication at any time without notice.

The products described in this document are not intended for use in implantation or other life support applications where malfunction may result in injury or death to persons. The information contained in this document does not affect or change Lenovo product specifications or warranties. Nothing in this document shall operate as an express or implied license or indemnity under the intellectual property rights of Lenovo or third parties. All information contained in this document was obtained in specific environments and is presented as an illustration. The result obtained in other operating environments may vary.

Lenovo may use or distribute any of the information you supply in any way it believes appropriate without incurring any obligation to you.

Any references in this publication to non-Lenovo Web sites are provided for convenience only and do not in any manner serve as an endorsement of those Web sites. The materials at those Web sites are not part of the materials for this Lenovo product, and use of those Web sites is at your own risk.

Any performance data contained herein was determined in a controlled environment. Therefore, the result obtained in other operating environments may vary significantly. Some measurements may have been made on development-level systems and there is no guarantee that these measurements will be the same on generally available systems. Furthermore, some measurements may have been estimated through extrapolation. Actual results may vary. Users of this document should verify the applicable data for their specific environment.

Trademarks

Lenovo, the Lenovo logo, ThinkSystem, Flex System, System x, NeXtScale System, and x Architecture are trademarks of Lenovo in the United States, other countries, or both.

Intel and Intel Xeon are trademarks of Intel Corporation in the United States, other countries, or both.

Internet Explorer, Microsoft, and Windows are trademarks of the Microsoft group of companies.

Linux is a registered trademark of Linus Torvalds.

Other company, product, or service names may be trademarks or service marks of others.

Important notes

Processor speed indicates the internal clock speed of the processor; other factors also affect application performance.

CD or DVD drive speed is the variable read rate. Actual speeds vary and are often less than the possible maximum.

When referring to processor storage, real and virtual storage, or channel volume, KB stands for 1 024 bytes, MB stands for 1 048 576 bytes, and GB stands for 1 073 741 824 bytes.

When referring to drive capacity or communications volume, MB stands for 1 000 000 bytes, and GB stands for 1 000 000 000 bytes. Total user-accessible capacity can vary depending on operating environments.

Maximum internal drive capacities assume the replacement of any standard drives and population of all drive bays with the largest currently supported drives that are available from Lenovo.

Maximum memory might require replacement of the standard memory with an optional memory module.

Each solid-state memory cell has an intrinsic, finite number of write cycles that the cell can incur. Therefore, a solid-state device has a maximum number of write cycles that it can be subjected to, expressed as total bytes written (TBW). A device that has exceeded this limit might fail to respond to system-generated commands or might be incapable of being written to. Lenovo is not responsible for replacement of a device that has exceeded its maximum guaranteed number of program/erase cycles, as documented in the Official Published Specifications for the device.

Lenovo makes no representations or warranties with respect to non-Lenovo products. Support (if any) for the non-Lenovo products is provided by the third party, not Lenovo.

Some software might differ from its retail version (if available) and might not include user manuals or all program functionality.

Electronic emission notices

When you attach a monitor to the equipment, you must use the designated monitor cable and any interference suppression devices that are supplied with the monitor.

Taiwan Region BSMI RoHS declaration

單元 Unit	限用物質及其化學符號 Restricted substances and its chemical symbols					
	鉛Lead (Pb)	汞Mercury (Hg)	鎘Cadmium (Cd)	六價鉻 Hexavalent chromium (Cr ⁶⁺)	多溴聯苯 Polybrominated biphenyls (PBB)	多溴二苯醚 Polybrominated diphenyl ethers (PBDE)
機架	○	○	○	○	○	○
外部蓋板	○	○	○	○	○	○
機械組零件	-	○	○	○	○	○
電纜組零件	-	○	○	○	○	○
印刷電路板	-	○	○	○	○	○
電源供應器	-	○	○	○	○	○
<p>備考1. “超出0.1 wt %”及“超出0.01 wt %”係指限用物質之百分比含量超出百分比含量基準值。 Note1: “exceeding 0.1wt%” and “exceeding 0.01 wt%” indicate that the percentage content of the restricted substance exceeds the reference percentage value of presence condition.</p> <p>備考2. “○”係指該項限用物質之百分比含量未超出百分比含量基準值。 Note2: “○”indicates that the percentage content of the restricted substance does not exceed the percentage of reference value of presence.</p> <p>備考3. “-”係指該項限用物質為排除項目。 Note3: The “-” indicates that the restricted substance corresponds to the exemption.</p>						

Taiwan import and export contact information

Contacts are available for Taiwan import and export information.

委製商/進口商名稱: 台灣聯想環球科技股份有限公司
 進口商地址: 台北市南港區三重路 66 號 8 樓
 進口商電話: 0800-000-702

Lenovo