

DPI C13 PDU+, DPI C13 3-phase PDU+,  
DPI C19 PDU+, and DPI C19 3-phase PDU+



# Installation and Maintenance Guide



DPI C13 PDU+, DPI C13 3-phase PDU+,  
DPI C19 PDU+, and DPI C19 3-phase PDU+



# Installation and Maintenance Guide

**Note:** Before using this information and the product it supports, read the warranty information in Appendix B, "IBM Statement of Limited Warranty Z125-4753-08 04/2004," on page 57 and the notices information in Appendix C, "Notices," on page 75.

**Third Edition (November 2007)**

**© Copyright International Business Machines Corporation 2006, 2007. All rights reserved.**

US Government Users Restricted Rights – Use, duplication or disclosure restricted by GSA ADP Schedule Contract with IBM Corp.

---

# Contents

<b>Safety</b>	v
<b>Chapter 1. Introduction</b>	1
The IBM Documentation CD	1
Hardware and software requirements	1
Using the Documentation Browser	2
Notices and statements in this document	3
Installation requirements	3
Parts that come with the PDU	4
Features of the PDU	5
Hardware components	6
Front view	6
Rear view	8
PDU load groups	8
<b>Chapter 2. Installing the PDU vertically in a rack cabinet</b>	11
Installing the PDU in the side of a rack cabinet	12
Installing the PDU in the side of an IBM Enterprise rack cabinet only	15
<b>Chapter 3. Installing the PDU horizontally in a rack cabinet</b>	19
<b>Chapter 4. Cabling the PDU</b>	25
Connecting the console	25
Connecting to a LAN	25
Connecting output devices	26
Connecting an environmental monitoring probe	26
<b>Chapter 5. Monitoring the power status</b>	27
Using the IBM DPI Configuration Utility	27
Using HyperTerminal	27
Configuration Utility menu choices	31
Setting the IP address	32
Using the Web interface	33
Starting the Web interface	33
Environment status and configuration	34
Modifying the basic settings	36
Changing the network information	42
History and event log summaries	43
<b>Chapter 6. Using the environmental monitoring probe</b>	45
Features	45
Installing the environmental monitoring probe	46
<b>Chapter 7. Customer replaceable unit parts</b>	49
<b>Chapter 8. PDU specifications</b>	51
<b>Appendix A. Getting help and technical assistance</b>	55
Before you call	55
Using the documentation	55
Getting help and information from the World Wide Web	55
Software service and support	56
Hardware service and support	56

IBM Taiwan product service . . . . .	56
<b>Appendix B. IBM Statement of Limited Warranty Z125-4753-08 04/2004</b>	<b>57</b>
Part 1 - General Terms . . . . .	57
Part 2 - Country-unique Terms . . . . .	60
Part 3 - Warranty Information . . . . .	72
<b>Appendix C. Notices</b> . . . . .	<b>75</b>
Trademarks . . . . .	75
Important notes. . . . .	76
Product recycling and disposal . . . . .	77
Battery return program . . . . .	78
Electronic emission notices . . . . .	80
Federal Communications Commission (FCC) statement . . . . .	80
Industry Canada Class A emission compliance statement . . . . .	80
Avis de conformité à la réglementation d'Industrie Canada . . . . .	80
Australia and New Zealand Class A statement . . . . .	80
United Kingdom telecommunications safety requirement. . . . .	80
European Union EMC Directive conformance statement. . . . .	80
Taiwanese Class A warning statement . . . . .	81
Chinese Class A warning statement . . . . .	81
Japanese Voluntary Control Council for Interference (VCCI) statement . . . . .	81
Korean Class A warning statement . . . . .	82
<b>Index</b> . . . . .	<b>83</b>

## Safety

Before installing this product, read the Safety Information.

قبل تركيب هذا المنتج، يجب قراءة الملاحظات الأمنية

Antes de instalar este produto, leia as Informações de Segurança.

在安装本产品之前，请仔细阅读 **Safety Information** (安全信息)。

安裝本產品之前，請先閱讀「安全資訊」。

Prije instalacije ovog produkta obavezno pročitajte Sigurnosne Upute.

Před instalací tohoto produktu si přečtěte příručku bezpečnostních instrukcí.

Læs sikkerhedsforskrifterne, før du installerer dette produkt.

Lees voordat u dit product installeert eerst de veiligheidsvoorschriften.

Ennen kuin asennat tämän tuotteen, lue turvaohjeet kohdasta Safety Information.

Avant d'installer ce produit, lisez les consignes de sécurité.

Vor der Installation dieses Produkts die Sicherheitshinweise lesen.

Πριν εγκαταστήσετε το προϊόν αυτό, διαβάστε τις πληροφορίες ασφαλείας (safety information).

לפני שתתקינו מוצר זה, קראו את הוראות הבטיחות.

A termék telepítése előtt olvassa el a Biztonsági előírásokat!

Prima di installare questo prodotto, leggere le Informazioni sulla Sicurezza.

製品の設置の前に、安全情報をお読みください。

본 제품을 설치하기 전에 안전 정보를 읽으십시오.

Пред да се инсталира овој продукт, прочитајте информацијата за безбедност.

Les sikkerhetsinformasjonen (Safety Information) før du installerer dette produktet.

Przed zainstalowaniem tego produktu, należy zapoznać się z książką "Informacje dotyczące bezpieczeństwa" (Safety Information).

Antes de instalar este produto, leia as Informações sobre Segurança.

Перед установкой продукта прочтите инструкции по технике безопасности.

Pred inštaláciou tohto zariadenia si pečítajte Bezpečnostné predpisy.

Pred namestitvijo tega proizvoda preberite Varnostne informacije.

Antes de instalar este producto, lea la información de seguridad.

Läs säkerhetsinformationen innan du installerar den här produkten.

**Important:**

All caution and danger statements in this documentation end with a number. This number is used to cross reference an English caution or danger statement with translated versions of the caution or danger statement in the *IBM Systems Safety Notices* document.

For example, if a caution statement ends with a number D005, translations for that caution statement appear in the *IBM Systems Safety Notices* document under D005.

Be sure to read all caution and danger statements in this documentation before performing the instructions. Read any additional safety information that comes with your server or optional device before you install the device.



**DANGER**

**Overloading a branch circuit is potentially a fire hazard and a shock hazard under certain conditions. To avoid these hazards, ensure that your system electrical requirements do not exceed branch circuit protection requirements. Refer to the information that is provided with your device or the power rating label for electrical specifications. (D002)**



**DANGER**

**Hazardous voltage, current, or energy levels are present inside any component that has this label attached. Do not open any cover or barrier that contains this label.**

(L001)







## **DANGER**

**Electrical voltage and current from power, telephone, and communication cables are hazardous.**

**To avoid a shock hazard:**

- **Do not connect or disconnect any cables or perform installation, maintenance, or reconfiguration of this product during an electrical storm.**
- **Connect all power cords to a properly wired and grounded electrical outlet. Ensure outlet supplies proper voltage and phase rotation according to the system rating plate.**
- **Connect any equipment that will be attached to this product to properly wired outlets.**
- **When possible, use one hand only to connect or disconnect signal cables.**
- **Never turn on any equipment when there is evidence of fire, water, or structural damage.**
- **Disconnect the attached power cords, telecommunications systems, networks, and modems before you open the device covers, unless instructed otherwise in the installation and configuration procedures.**
- **Connect and disconnect cables as described below when installing, moving, or opening covers on this product or attached devices.**

**To Disconnect:**

- 1. Turn everything OFF (unless instructed otherwise).**
- 2. Remove power cords from the outlet.**
- 3. Remove the signal cables from connectors.**
- 4. Remove all cables from devices.**

**To Connect:**

- 1. Turn everything OFF (unless instructed otherwise).**
- 2. Attach all cables to devices.**
- 3. Attach signal cables to connectors.**
- 4. Attach the power cords to outlets.**
- 5. Turn device ON.**

**(D005)**

The following general safety information should be used for all rack-mounted devices:



#### **DANGER**

- **Always lower the leveling pads on the rack cabinet.**
- **Always install stabilizer brackets on the rack cabinet.**
- **To avoid hazardous conditions due to uneven mechanical loading, always install the heaviest devices in the bottom of the rack cabinet. Always install servers and optional devices starting from the bottom of the rack cabinet.**
- **Rack-mounted devices are not to be used as a shelf or work space. Do not place any object on top of rack-mounted devices.**
- **Each rack cabinet might have more than one power cord. Be sure to disconnect all power cords in the rack cabinet before servicing any device in the rack cabinet.**
- **Connect all devices installed in a rack cabinet to power devices installed in the same rack cabinet. Do not plug a power cord from a device installed in one rack cabinet into a power device installed in a different rack cabinet.**
- **An electrical outlet that is not correctly wired could place hazardous voltage on the metal parts of the system or the devices that attach to the system. It is the responsibility of the customer to ensure that the outlet is correctly wired and grounded to prevent an electrical shock.**

#### **CAUTION:**

- **Do not install a unit in a rack where the internal rack ambient temperatures will exceed the manufacturer's recommended ambient temperature for all your rack-mounted devices.**
- **Do not install a unit in a rack where the air flow is compromised. Ensure that air flow is not blocked or reduced on any side, front, or back of a unit used for air flow through the unit.**
- **Consideration should be given to the connection of the equipment to the supply circuit so that overloading of the circuits does not compromise the supply wiring or overcurrent protection. To provide the correct power connection to a rack, refer to the rating labels located on the equipment in the rack to determine the total power requirement of the supply circuit.**
- **(For sliding drawers.) Do not pull out or install any drawer or feature if the rack stabilizer brackets are not attached to the rack. Do not pull out more than one drawer at a time. The rack may become unstable if you pull out more than one drawer at a time.**
- **(For fixed drawers.) This drawer is a fixed drawer and must not be moved for servicing unless specified by manufacturer. Attempting to move the drawer partially or completely out of the rack may cause the rack to become unstable or cause the drawer to fall out of the rack.**

**(R001)**

---

## Chapter 1. Introduction

The IBM® power distribution unit plus (PDU+) products have power monitoring capabilities. These PDU+ products enable you to connect up to nine or 12 (depending on the PDU model) servers or rack PDUs to a single dedicated power source. The following single-phase and three-phase PDUs are available:

- IBM DPI® C13 PDU+ (IBM part number 39M2816)
- IBM DPI C13 3-phase PDU+ (IBM part number 39M2817)
- IBM DPI C19 PDU+ (IBM part number 39M2818)
- IBM DPI C19 3-phase PDU+ (IBM part number 39M2819)

This release contains enhancements that enable the IBM Systems Director Active Energy Manager product to monitor the IBM PDU+ products. The Active Energy Manager solution is an IBM Director extension that measures and reports server power consumption as it occurs. Active Energy Manager includes a feature to associate IBM Director-managed resources with the power outlets on the PDU+. You can use the graphing capability of Active Energy Manager to show a trending line for power that is being drawn by load groups of the PDU+, showing which systems are connected to the load groups.

If firmware and documentation updates are available, you can download them from the IBM Web site. The PDU+ might have features that are not described in the documentation that comes with the PDU+, and the documentation might be updated occasionally to include information about those features, or technical updates might be available to provide additional information that is not included in the PDU+ documentation. To check for updates, complete the following steps.

**Note:** Changes are made periodically to the IBM Web site. Procedures for locating firmware and documentation might vary slightly from what is described in this document.

1. Go to <http://www.ibm.com/systems/support/>.
2. Click **Hardware upgrades**.
3. On the “Support for IBM Upgrades” page, in the **Product family** field, select **Power**.
4. In the **Type** field, select **Distributed power interconnect (DPI)**.
5. In the **Part number** field, select your PDU+ part number.
6. Click **Go**.
7. On the “Support for Power” page, click **Downloads** for firmware updates, or click **Install/use** for documentation updates.

---

## The IBM Documentation CD

The IBM *Documentation* CD contains documentation for the PDU in Portable Document Format (PDF) and includes the IBM Documentation Browser to help you find information quickly.

## Hardware and software requirements

The IBM *Documentation* CD requires the following minimum hardware and software:

- Microsoft Windows XP, Windows 2000, or Red Hat Linux
- 100 MHz microprocessor

- 32 MB of RAM
- Adobe Acrobat Reader 3.0 (or later) or xpdf, which comes with Linux operating systems

## Using the Documentation Browser

Use the Documentation Browser to browse the contents of the CD, read brief descriptions of the documents, and view documents, using Adobe Acrobat Reader or xpdf. The Documentation Browser automatically detects the regional settings in your computer and displays the documents in the language for that region (if available). If a document is not available in the language for that region, the English-language version is displayed.

Use one of the following procedures to start the Documentation Browser:

- If Autostart is enabled, insert the CD into the CD or DVD drive. The Documentation Browser starts automatically.
- If Autostart is disabled or is not enabled for all users, use one of the following procedures:
  - If you are using a Windows operating system, insert the CD into the CD or DVD drive and click **Start --> Run**. In the **Open** field, type  
`e:\win32.bat`  
  
 where *e* is the drive letter of the CD or DVD drive, and click **OK**.
  - If you are using Red Hat Linux, insert the CD into the CD or DVD drive; then, run the following command from the `/mnt/cdrom` directory:  
`sh runlinux.sh`

Select the PDU from the **Product** menu. The **Available Topics** list displays all the documents for the PDU. Some documents might be in folders. A plus sign (+) indicates each folder or document that has additional documents under it. Click the plus sign to display the additional documents.

When you select a document, a description of the document is displayed under **Topic Description**. To select more than one document, press and hold the Ctrl key while you select the documents. Click **View Book** to view the selected document or documents in Acrobat Reader or xpdf. If you selected more than one document, all the selected documents are opened in Acrobat Reader or xpdf.

To search all the documents, type a word or word string in the **Search** field and click **Search**. The documents in which the word or word string appears are listed in order of the most occurrences. Click a document to view it, and press Ctrl+F to use the Acrobat search function, or press Alt+F to use the xpdf search function within the document.

Click **Help** for detailed information about using the Documentation Browser.

---

## Notices and statements in this document

The caution and danger statements in this document are also in the multilingual *Systems Safety Notices* document, which is on the IBM *Documentation* CD. Each statement is numbered for reference to the corresponding statement in your language in the *Systems Safety Notices* document.

The following notices and statements are used in this document:

- **Note:** These notices provide important tips, guidance, or advice.
- **Important:** These notices provide information or advice that might help you avoid inconvenient or problem situations.
- **Attention:** These notices indicate potential damage to programs, devices, or data. An attention notice is placed just before the instruction or situation in which damage might occur.
- **Caution:** These statements indicate situations that can be potentially hazardous to you. A caution statement is placed just before the description of a potentially hazardous procedure step or situation.
- **Danger:** These statements indicate situations that can be potentially lethal or extremely hazardous to you. A danger statement is placed just before the description of a potentially lethal or extremely hazardous procedure step or situation.

---

## Installation requirements

You will need the following tools to install the PDU in a rack cabinet:

- One Phillips screwdriver
- One 10 mm (11/32 in.) wrench
- One cage-nut-insertion tool or flat-blade screwdriver (for installing cage nuts in some rack cabinets)

You can install a PDU vertically in the side of a rack cabinet or horizontally within 1 U<sup>1</sup> of EIA mounting space in a rack cabinet.

- For vertical mounting instructions, see Chapter 2, “Installing the PDU vertically in a rack cabinet,” on page 11.
- For horizontal mounting instructions, see Chapter 3, “Installing the PDU horizontally in a rack cabinet,” on page 19.

**Attention:** Horizontal installation of the PDU is not supported during relocation or shipping of a rack cabinet. Before you relocate the rack cabinet, you must remove any horizontally mounted PDU from the EIA mounting space.

---

1. One U is equal to 4.45 cm (1.75 in.)

---

## Parts that come with the PDU

**Note:** The illustrations in this document might differ slightly from your hardware.

The following parts come with the PDU:

- One PDU (some models include detached power cords)

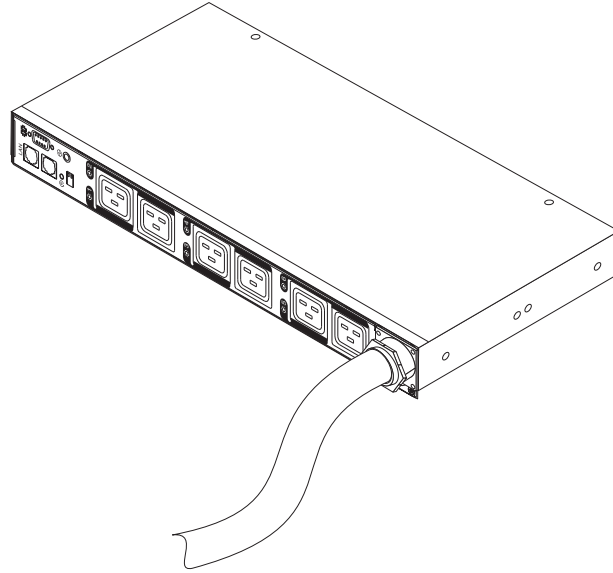

- Two vertical-mounting brackets (for all rack cabinets)

**Note:** This part does not come with the DPI C13 3-phase PDU+.

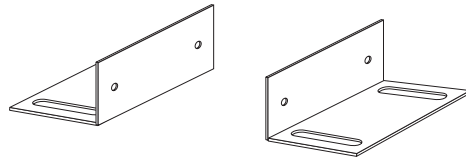

- Two short mounting brackets (for horizontal mounting for all rack cabinets; for vertical mounting in IBM Enterprise rack cabinets only)

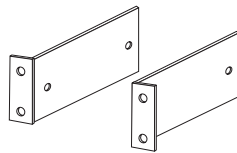

- Two long mounting brackets (for horizontal mounting in all rack cabinets)

**Note:** This part does not come with the DPI C13 3-phase PDU+.

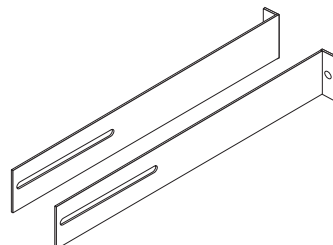

- One cable-management bracket (for vertical installations)

**Note:** This part does not come with the DPI C13 3-phase PDU+.

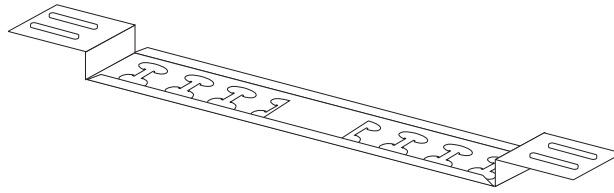

- One DB9-to-RJ-45 cable

**Note:** This part does not come with the DPI C13 3-phase PDU+.

- One 1 U blank filler panel

**Note:** This part does not come with the DPI C13 3-phase PDU+.



- Miscellaneous hardware kit (for attaching the mounting brackets to the PDU and installing the PDU in a rack cabinet)

**Note:** The DPI C13 3-phase PDU+ comes with four M3 flat-head screws, four M6 flange-head screws, and four M6 clip nuts.

- Cable straps

**Note:** This part does not come with the DPI C13 3-phase PDU+.

**Notes:**

1. Power cables for devices that you will connect to the PDU do not come with the PDU.
2. You will have some unused parts depending on how you install the PDU.

---

## Features of the PDU

The PDU has the following features:

- Versatile sensors that are supported through environmental monitoring probe inputs

**Note:** This feature requires the environmental monitoring probe, which comes with the PDU+ models, except the DPI C13 3-phase PDU+. For the DPI C13 3-phase PDU+, you can order the environmental monitoring probe at the time of purchase.

- Remote monitoring of connected devices and sensors
- Monitoring of the PDU manually, remotely through IBM Systems Director Active Energy Manager, or remotely through a console or network
- Comprehensive power management and flexible configuration through a Web browser, NMS, Telnet, SNMP, or HyperTerminal (console)
- Configurable user-security control
- Easy-to-use interface to display input and output status
- Detailed data-logging for statistical analysis and diagnostics
- Upgrade utility for easy firmware updates
- Event notification through SNMP trap or e-mail alerts

- Daily history report through e-mail
- Address-specific IP security masks to prevent unauthorized access

---

## Hardware components

The following sections provide descriptions of the front and rear components on the PDU.

### Front view

The following illustration shows the components and controls on the front of the DPI C13 PDU+ and the DPI C13 3-phase PDU+.

**Note:** The DPI C13 3-phase PDU+ comes with an attached power cord.

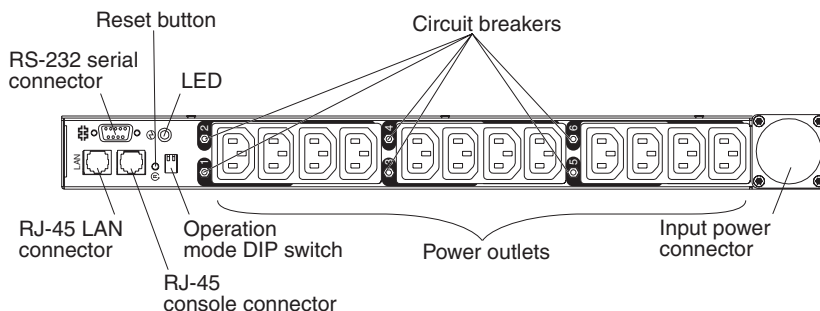

The following illustration shows the components and controls on the front of the DPI C19 PDU+ and the DPI C19 3-Phase PDU+.

**Note:** The DPI C19 3-Phase PDU+ comes with an attached power cord.

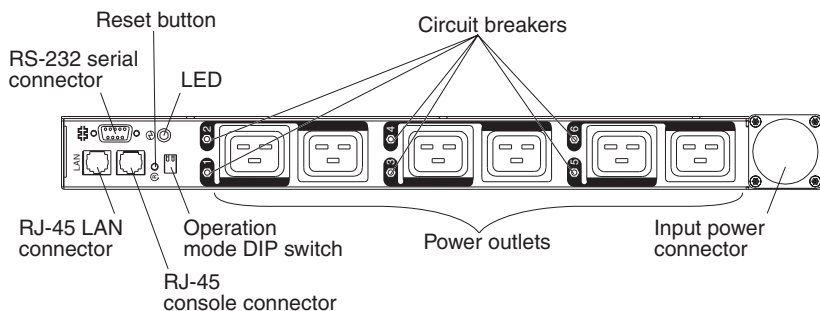

#### RS-232 serial connector

Use the RS-232 serial connector to update the PDU firmware.

#### Reset button

Use this button to reset the PDU for communication purposes only. Resetting the PDU does not affect the loads.

**LED** The green LED shows the PDU input voltage status. When this LED is lit, the PDU is receiving voltage. If the input voltage is too low, this LED is flashing.

#### Circuit breakers

If the load current rating for a power outlet exceeds 20 A, the associated circuit breaker is activated (the breaker pole pops out) and power to the



outlet is turned off automatically. To reset the circuit breaker, firmly press the breaker pole until it locks into place.

**Note:** To manually disconnect power to a device that is connected to the PDU, disconnect the device power cord from the PDU power outlet.

#### **Input power connector**

Connect a power cord to this connector.

**Note:** Some PDU models come with an attached power cord.

#### **Power outlets**

You can connect a device to each power outlet. There are either six or 12 power outlets on the front of the PDU, depending on the PDU model.

**Note:** There are three C13 power outlets on the rear of the DPI C19 PDU+ and the DPI C19 3-Phase PDU+ models.

#### **Operation mode DIP switch**

Use the switch to set the mode of operation for the PDU. The default mode is S1 off, S2 off for normal operation.

##### **1=Off, 2=Off**

The PDU will run normal operational firmware.

##### **1=On, 2=On**

The PDU will start in diagnostics mode.

##### **1=On, 2=Off**

Serial upgrade mode. You can upgrade the PDU firmware from the serial connection if the network upgrade is not available.

##### **1=Off 2=On**

Read-only mode. The device will run normal operational firmware, but no parameters of the device can be changed by a user.

#### **RJ-45 console connector**

Connect the DB9-to-RJ-45 cable that comes with the PDU to this connector and to the serial (COM) connector on a workstation or notebook computer, and use the workstation or notebook computer as a configuration console. You can also connect an environmental monitoring probe to this connector. The environmental monitoring probe monitors humidity and temperature. The connection of an environmental monitoring probe is automatically detected.

Green LED (on the left in a horizontal orientation; on the top in a vertical orientation):

- This LED is lit when the power to the PDU is turned on.
- This LED flashes while the PDU is starting to indicate startup status.

Amber LED (on the right in a horizontal orientation; on the bottom in a vertical orientation):

- This LED flashes while the PDU is communicating with a server or computer or when it is reading data from an environmental monitoring probe.

### RJ-45 Ethernet (LAN) connector

Use this connector to configure the PDU through a LAN. The Ethernet connector supports 10/100 auto sense network connection.

Green LED (on the left):

- This LED is lit when the PDU is connected to a 100 Mb network.
- This LED flashes while data is transmitted and received.

Amber LED (on the right):

- This LED is lit when the PDU is connected to a 10 Mb network.
- This LED flashes while data is transmitted and received.

## Rear view

The following illustration shows the rear of the DPI C13 PDU+ and the DPI C13 3-phase PDU+.



The following illustration shows the power outlets on the rear of the DPI C19 PDU+ and the DPI C19 3-Phase PDU+.

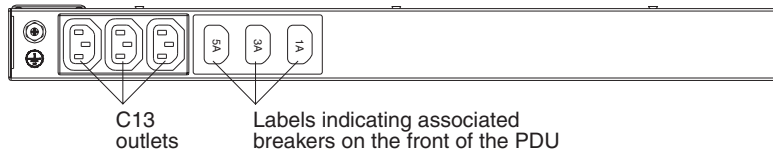

---

## PDU load groups

The PDU load groups are described in the following tables.

*Table 1. DPI C13 PDU+ and DPI C13 3-phase PDU+ load groups*

Circuit breaker number	Associated front outlets
1	1 and 2
2	3 and 4
3	5 and 6
4	7 and 8
5	9 and 10
6	11 and 12

*Table 2. DPI C19 PDU+ and DPI C19 3-phase PDU+ load groups*

<b>Circuit breaker number</b>	<b>Associated front outlet</b>	<b>Associated rear outlet</b>
1	1	1A
2	2	
3	3	3A
4	4	
5	5	5A
6	6	



---

## Chapter 2. Installing the PDU vertically in a rack cabinet

This chapter describes how to install the PDU vertically in a rack cabinet. To install the PDU in the side of an IBM Enterprise rack cabinet, see “Installing the PDU in the side of an IBM Enterprise rack cabinet only” on page 15.



### DANGER

Electrical voltage and current from power, telephone, and communication cables are hazardous.

**To avoid a shock hazard:**

- Do not connect or disconnect any cables or perform installation, maintenance, or reconfiguration of this product during an electrical storm.
- Connect all power cords to a properly wired and grounded electrical outlet. Ensure outlet supplies proper voltage and phase rotation according to the system rating plate.
- Connect any equipment that will be attached to this product to properly wired outlets.
- When possible, use one hand only to connect or disconnect signal cables.
- Never turn on any equipment when there is evidence of fire, water, or structural damage.
- Disconnect the attached power cords, telecommunications systems, networks, and modems before you open the device covers, unless instructed otherwise in the installation and configuration procedures.
- Connect and disconnect cables as described below when installing, moving, or opening covers on this product or attached devices.

**To Disconnect:**

1. Turn everything OFF (unless instructed otherwise).
2. Remove power cords from the outlet.
3. Remove the signal cables from connectors.
4. Remove all cables from devices.

**To Connect:**

1. Turn everything OFF (unless instructed otherwise).
2. Attach all cables to devices.
3. Attach signal cables to connectors.
4. Attach the power cords to outlets.
5. Turn device ON.

(D005)

---

## Installing the PDU in the side of a rack cabinet

The mounting holes on the upper and lower side braces in a rack side compartment must be between 48.6 cm (19.1 in.) and 56.9 cm (22.4 in.) apart. If your rack cabinet has movable side braces, see the rack cabinet documentation for information about relocating the side braces if they are not already spaced for this installation.

**Note:** Removing the rack doors and side panels might make installation easier. See the rack cabinet documentation for more information.

Review the documentation that comes with your rack cabinet for safety and cabling information. When you install the PDU in a rack cabinet, observe the following precautions:

- Make sure that the room air temperature is below 35°C (95°F).
- Do not block any air vents; usually 15 cm (6 in.) of air space provides proper airflow.
- Connect all power cords to properly wired and grounded electrical outlets.
- Do not overload the power outlet when you install multiple devices in the rack cabinet.

To install a PDU in the side of a rack cabinet by using the vertical mounting brackets, complete the following steps:

1. Align the vertical mounting brackets to the front of the PDU and attach the brackets to the PDU with two M3 x 5 screws per bracket. Use the screws that come with the PDU. You can install the PDU in a rack cabinet with the power outlets facing the rear or the front of the rack cabinet.

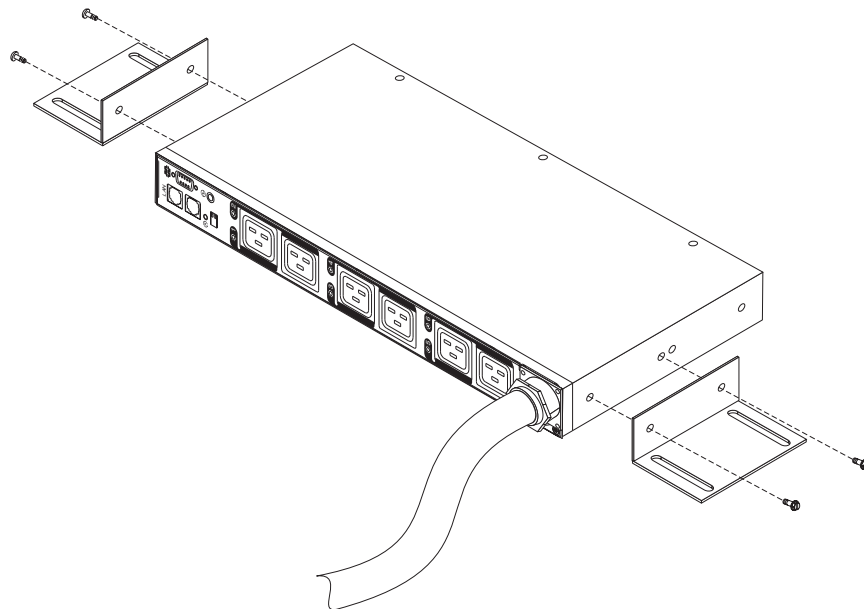

2. Hold the PDU in the side of the rack cabinet, and attach the vertical mounting brackets to the side braces with four M6 screws and nuts that come with the PDU.

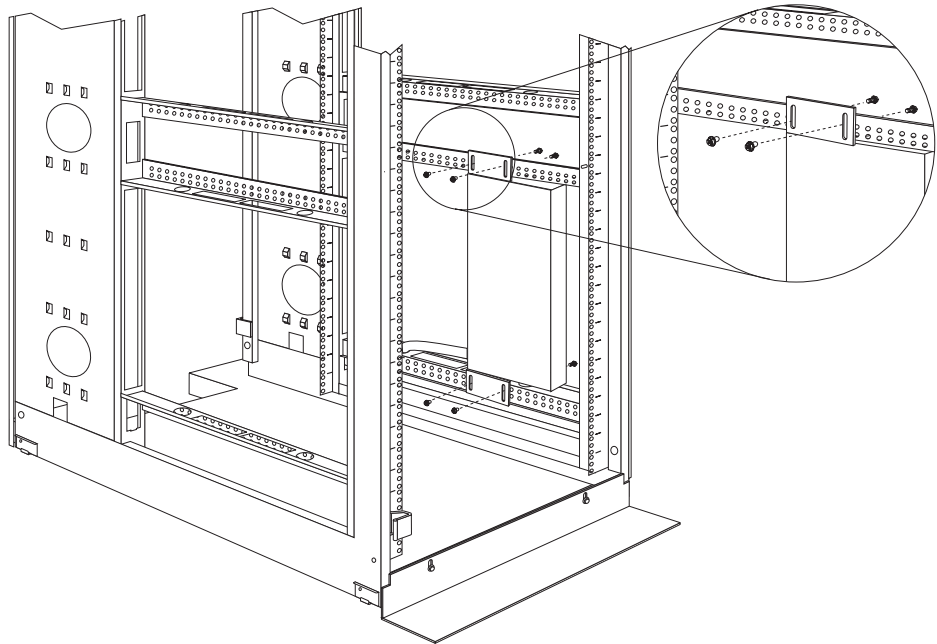

**Notes:**

- a. Leave enough space to connect, route, and disconnect power cords.
- b. If you are installing a cable-management bracket in the same side of the rack cabinet, leave enough space between the outlet side of the PDU and the EIA mounting flanges for the cable-management bracket installation.

**Attention:** You must disconnect the main input power before you connect or disconnect the input power cord from the PDU.

3. If the PDU comes with a detached power cord, connect the power cord. Align the connector on the power cord that comes with the PDU with the connector on the front of the PDU, turning as necessary for key alignment; then, turn the twist-lock on the connector clockwise until it locks into place.

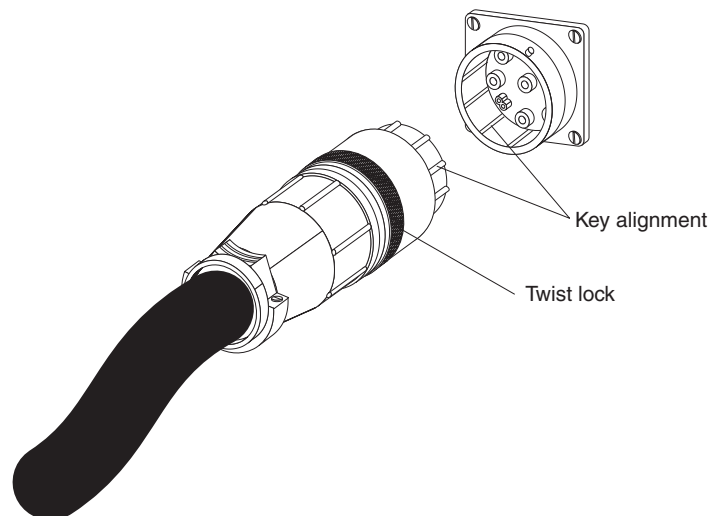

4. Install the optional cable-management bracket beside the PDU with four M6 screws and nuts that come with the PDU.

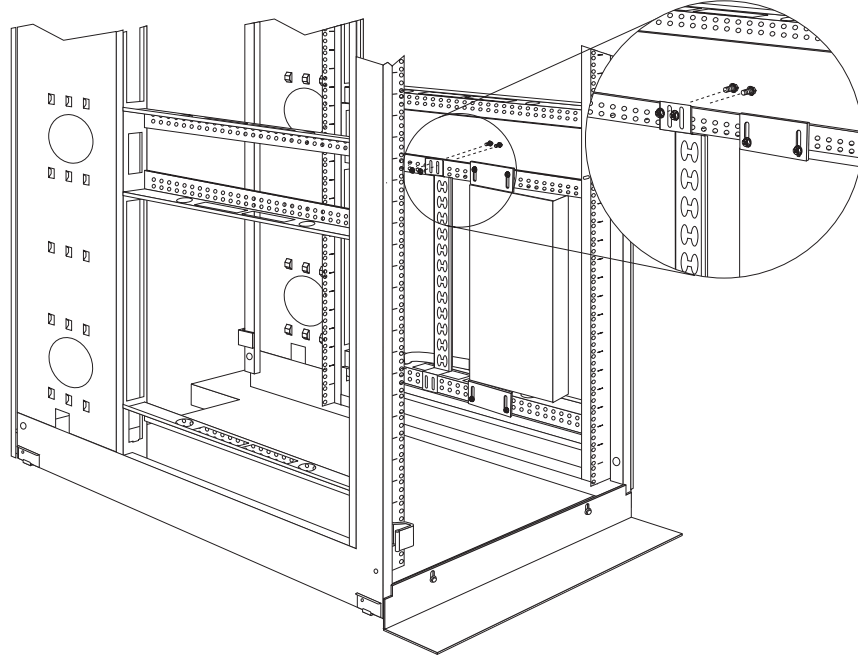

5. Route the power cord from the PDU toward the rack cabinet side braces; then, route the power cord along a side brace toward the back of the rack cabinet, and secure the power cord with the cable straps that come with the PDU.
6. Route the power cord toward a dedicated power source. Use the provided cable straps to secure the power cord along the way. If the power cord must exit the rack cabinet to connect to a power source, use the openings in the rack cabinet.
7. Connect the power cord to a properly wired and grounded dedicated power source. Then, you can connect servers or rack PDUs in the rack cabinet to the power outlets on the PDU.



- Route all the other power cords neatly, using the cable-management bracket if it is installed, and secure the power cords with cable straps.

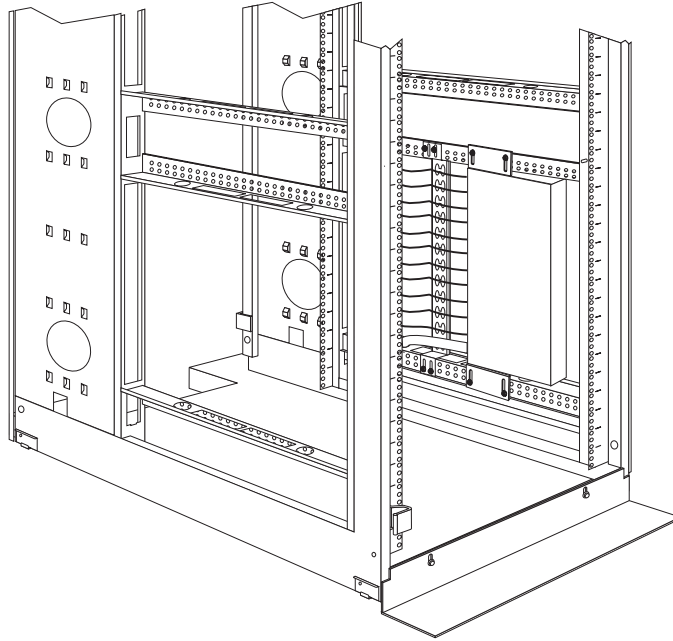

**Note:** To route a power cord through the cable-management bracket, route the cord through an opening in the bracket and against an upper or lower tab on the bracket, as shown in the following illustration. Use cable straps as required.

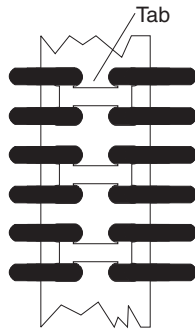

---

## Installing the PDU in the side of an IBM Enterprise rack cabinet only

**Note:** Removing the rack doors and side panels might make installation easier. See the rack cabinet documentation for more information.

Review the documentation that comes with your rack cabinet for safety and cabling information. When you install the PDU in a rack cabinet, observe the following precautions:

- Make sure that the room air temperature is below 35°C (95°F).
- Do not block any air vents; usually 15 cm (6 in.) of air space provides proper airflow.
- Connect all power cords to properly wired and grounded electrical outlets.
- Do not overload the power outlet when you install multiple devices in the rack.

You must use clip nuts to install the mounting brackets. Clip nuts come with the PDU and are installed on the rack mounting flanges, as shown in the following illustration.

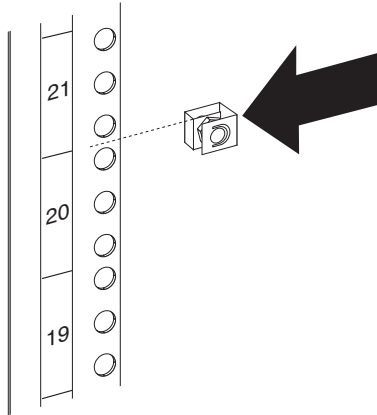

To install the PDU in the 1 U mounting space in the side of an IBM Enterprise rack cabinet, complete the following steps:

1. Align the vertical-mounting brackets to the front of the PDU. Make sure that you attach the brackets so that the power outlets face the rear of the rack cabinet.

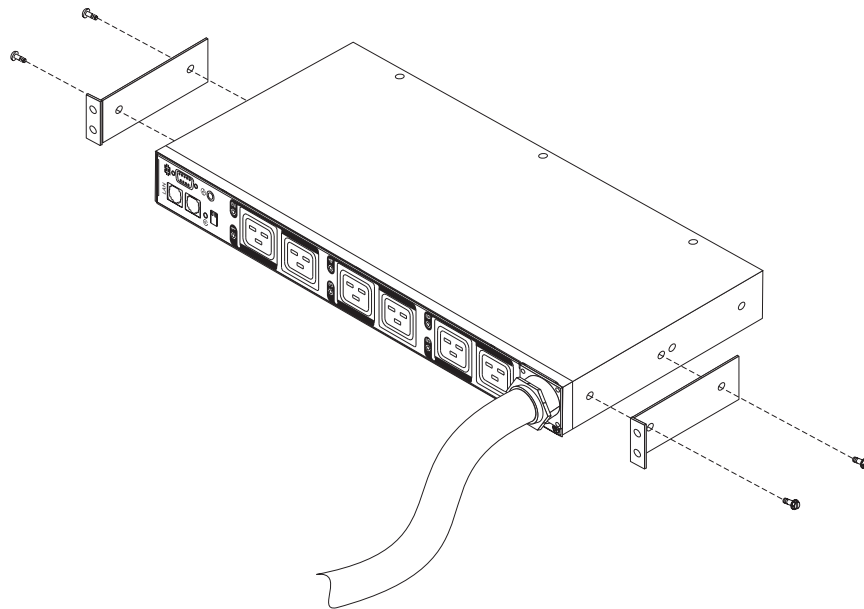

2. Attach the brackets to the PDU with two M3 x 5 screws per bracket. Use the screws that come with the PDU.

3. Align the PDU with the opening in the side of the rack cabinet; then, while you hold the PDU in place, attach the brackets to the rack-mounting flanges with four clip nuts and four M6 screws that come with the PDU.

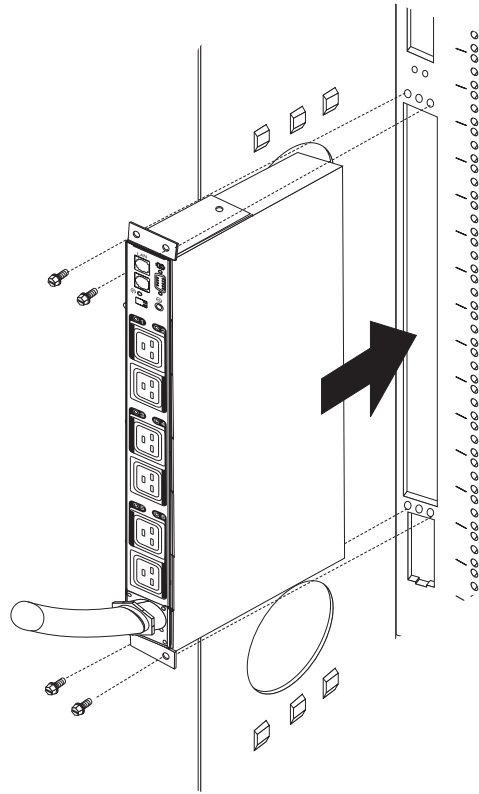

**Attention:** You must disconnect the main input power before you connect or disconnect the input power cord from the PDU.

4. If the PDU comes with a detached power cord, connect the power cord. Align the connector on the power cord that comes with the PDU with the connector on the front of the PDU, turning as necessary for key alignment; then, turn the twist-lock on the connector clockwise until it locks into place.

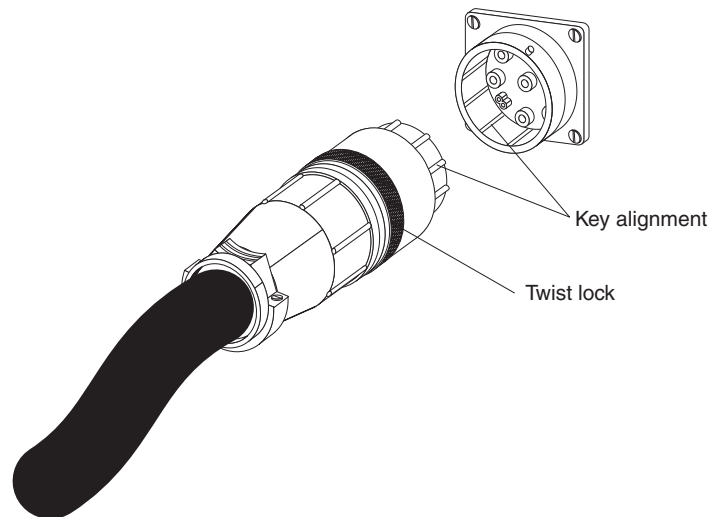

5. Route the power cord from the PDU toward the rack cabinet side braces; then, route the power cord along a side brace toward the back of the rack cabinet, and secure the power cord with the cable straps that come with the PDU.
6. Route the power cord toward a dedicated power source. Use the provided cable straps to secure the power cord along the way. If the power cord must exit the rack cabinet to connect to a power source, use the openings in the rack cabinet.
7. Connect the power cord to a properly wired and grounded dedicated power source. Then, you can connect servers or rack PDUs in the rack cabinet to the power outlets on the PDU.
8. Route all the other power cords neatly and secure the power cords with cable straps.

## Chapter 3. Installing the PDU horizontally in a rack cabinet

**Attention:** Horizontal installation of a PDU is not supported during relocation or shipping of a rack cabinet. You must remove any horizontally mounted PDUs from the EIA mounting space before you relocate the rack cabinet.

**Note:** Removing the rack doors and side panels might make installation easier. See the rack cabinet documentation for more information.

Review the documentation that comes with your rack cabinet for safety and cabling information. When you install the PDU in a rack cabinet, observe the following precautions:

- Make sure that the room air temperature is below 35°C (95°F).
- Do not block any air vents; usually 15 cm (6 in.) of air space provides proper airflow.
- Plan the device installation starting from the bottom of the rack cabinet.
- Install the heaviest device in the bottom of the rack cabinet.
- Do not extend more than one device out of the rack cabinet at the same time.
- Connect all power cords to properly wired and grounded electrical outlets.
- Do not overload the power outlet when you install multiple devices in the rack cabinet.

Use cage nuts for rack cabinets with square holes, and use clip nuts for rack cabinets with round holes. If your rack cabinet requires cage nuts, use a cage-nut-insertion tool or a flat-blade screwdriver to install them.

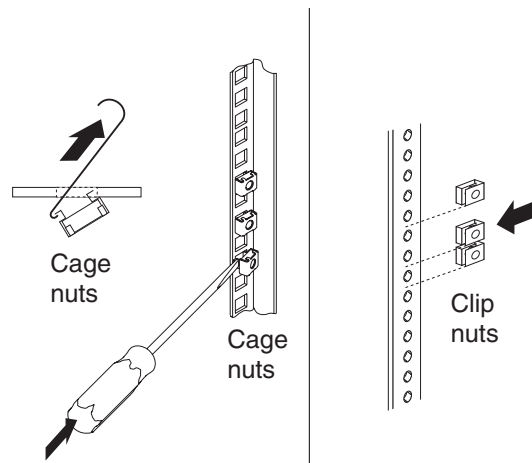



## **DANGER**

**Electrical voltage and current from power, telephone, and communication cables are hazardous.**

**To avoid a shock hazard:**

- **Do not connect or disconnect any cables or perform installation, maintenance, or reconfiguration of this product during an electrical storm.**
- **Connect all power cords to a properly wired and grounded electrical outlet. Ensure outlet supplies proper voltage and phase rotation according to the system rating plate.**
- **Connect any equipment that will be attached to this product to properly wired outlets.**
- **When possible, use one hand only to connect or disconnect signal cables.**
- **Never turn on any equipment when there is evidence of fire, water, or structural damage.**
- **Disconnect the attached power cords, telecommunications systems, networks, and modems before you open the device covers, unless instructed otherwise in the installation and configuration procedures.**
- **Connect and disconnect cables as described below when installing, moving, or opening covers on this product or attached devices.**

**To Disconnect:**

1. **Turn everything OFF (unless instructed otherwise).**
2. **Remove power cords from the outlet.**
3. **Remove the signal cables from connectors.**
4. **Remove all cables from devices.**

**To Connect:**

1. **Turn everything OFF (unless instructed otherwise).**
2. **Attach all cables to devices.**
3. **Attach signal cables to connectors.**
4. **Attach the power cords to outlets.**
5. **Turn device ON.**

**(D005)**

To install the PDU horizontally in a rack cabinet, complete the following steps:

1. Align the short mounting brackets with the holes in the front of the PDU and attach the brackets to the PDU with two M3 flat-head screws per bracket. Use the screws that come with the rack-mounting kit.

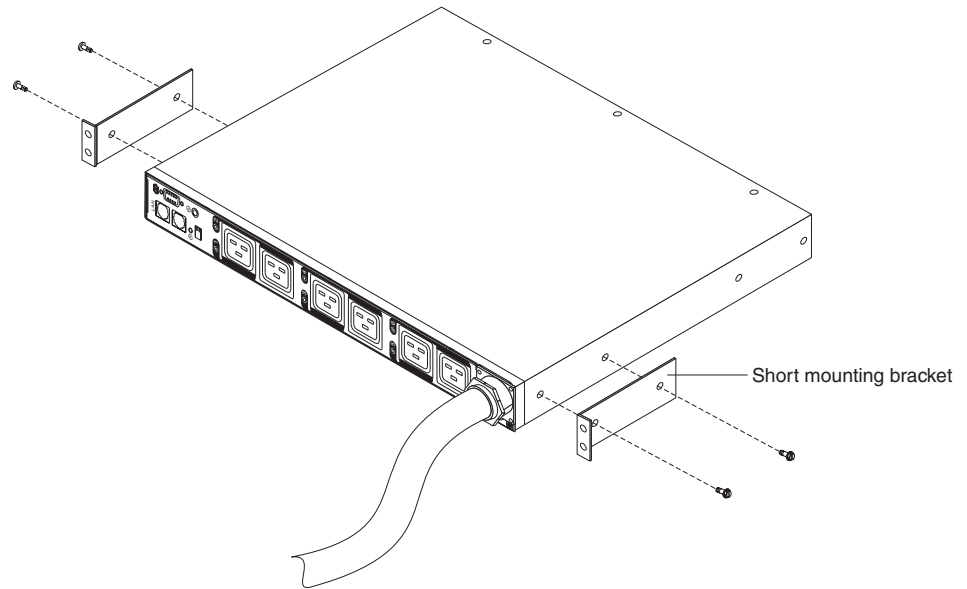

2. Align the long mounting brackets with the holes in the rear of the PDU and attach the brackets to the PDU with two M3 pan-head screws with captive lock washers per bracket. Use the screws that come with the rack-mounting kit.

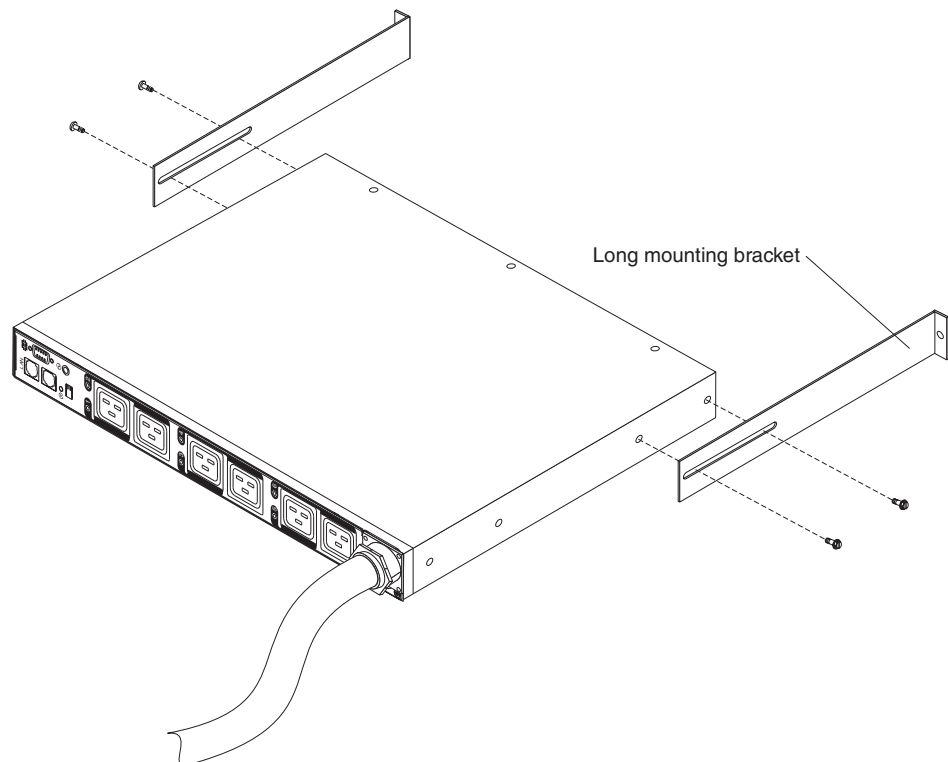

3. Hold the PDU at a slight angle and carefully insert it into the 1 U mounting space in the rack cabinet. Pushing in slightly on both of the long mounting brackets helps clear the brackets from the rack flanges.

- Secure the end of the PDU that has the short mounting brackets to the rack cabinet first. Make sure that the short mounting brackets are aligned with the outside of the rack flanges. Attach the brackets to the rack flanges with two M6 screws and two cage nuts or clip nuts per bracket. Use the cage nuts or clip nuts and the screws that come with the rack-mounting kit.

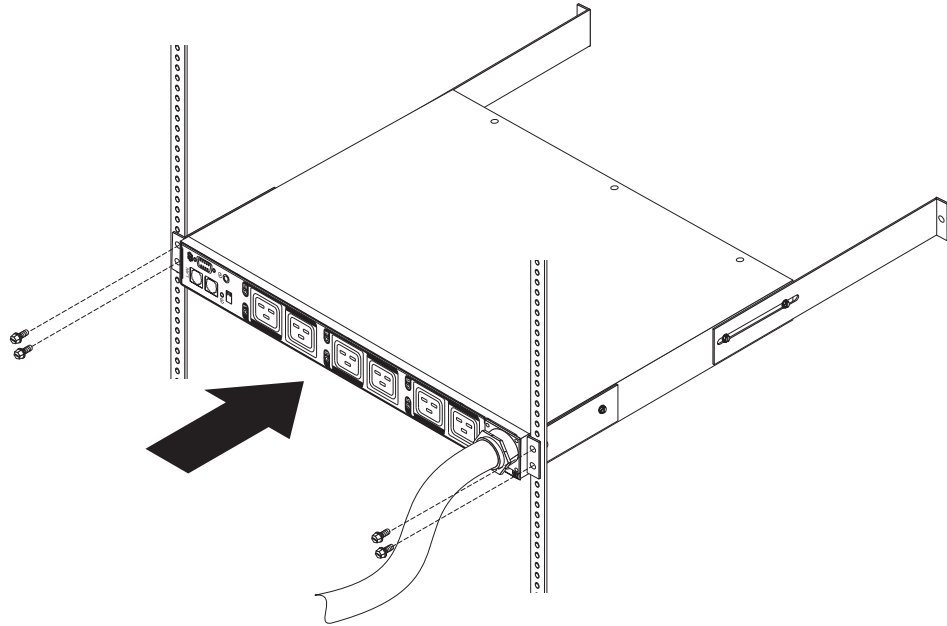

- Secure the long mounting brackets and the 1 U blank filler panel to the rack cabinet.

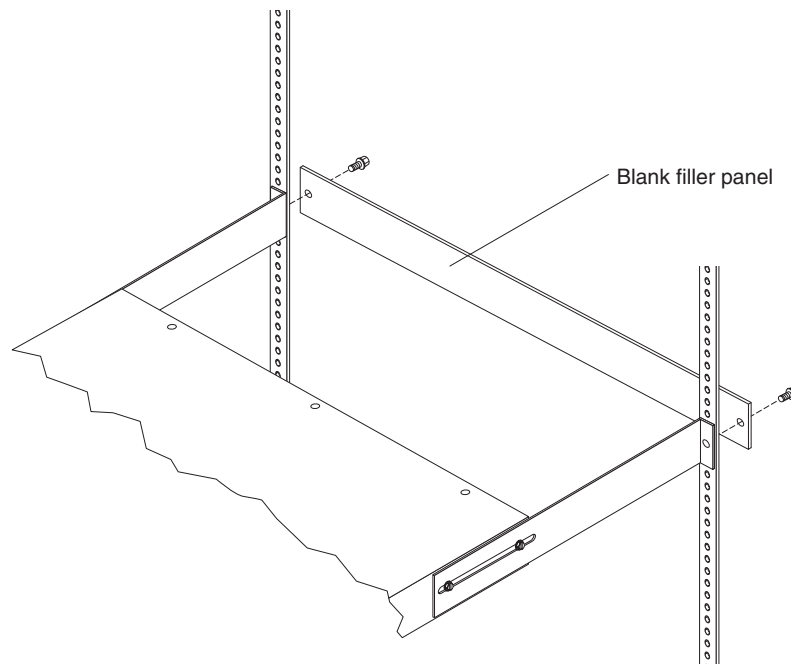

- Adjust the long mounting brackets to fit the depth of the rack cabinet.
- Make sure that the long mounting brackets are aligned with the inside of the rack flanges.



- c. Align the blank filler panel on the outside of the rack flanges.
  - d. Attach the filler panel to the rack flanges and then to the long mounting bracket with one M6 screw per bracket.
  - e. Tighten the M3 pan-head screws that secure the long mounting brackets to the PDU.
6. If the PDU comes with a detached power cord, connect the power cord. Align the connector on the power cord that comes with the PDU with the connector on the front of the PDU, turning as necessary for key alignment; then, turn the twist-lock on the connector clockwise until it locks into place.

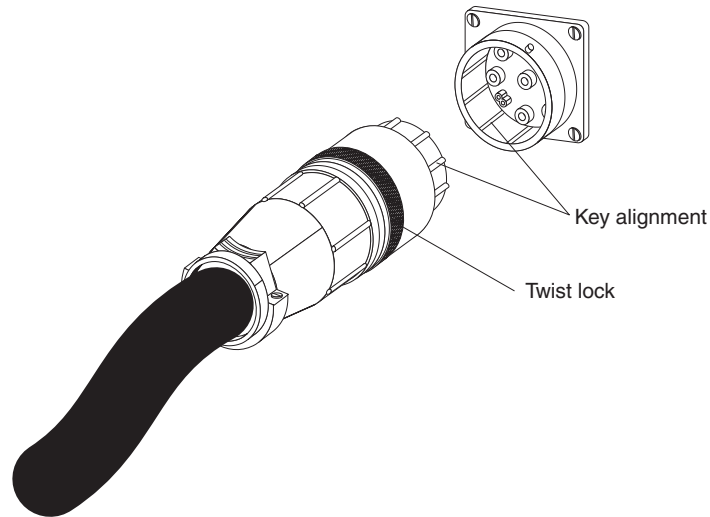

7. Route the power cord from the PDU toward the rack cabinet side braces; then, route the power cord along a side brace toward the back of the rack cabinet, and secure the power cord with the cable straps that come with the PDU.
8. Route the power cord toward a dedicated power source. Use the provided cable straps to secure the power cord along the way. If the power cord must exit the rack cabinet to connect to a power source, use the openings in the rack cabinet.
9. Connect the power cord to a properly wired and grounded dedicated power source. Then, you can connect servers or rack PDUs in the rack cabinet to the power outlets on the PDU.
10. Route all the other power cords neatly and secure the power cords with cable straps.



---

## Chapter 4. Cabling the PDU

This chapter provides information about cabling the PDU, connecting power, and connecting devices.

---

### Connecting the console

Use the DB9-to-RJ-45 cable that comes with the PDU to connect the serial (COM) connector on a workstation or notebook computer to the RJ-45 console connector on the PDU, as shown in the following illustration.

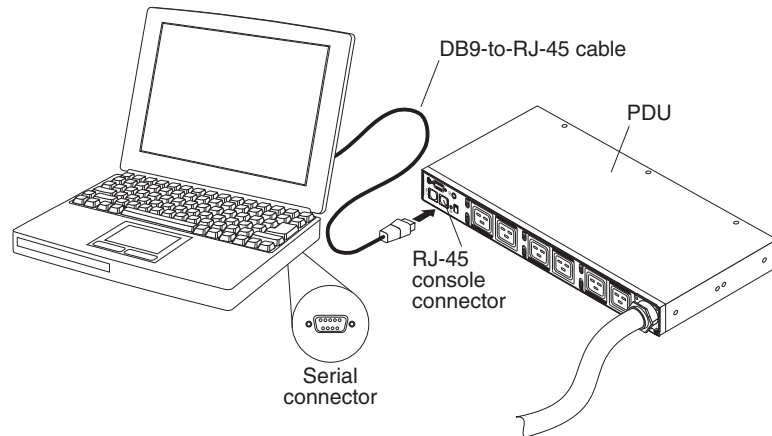

For more information, see “Using the IBM DPI Configuration Utility” on page 27.

---

### Connecting to a LAN

You can monitor the PDU power outlets and digital outputs over a network through the Web interface, using a LAN connection.

Connect a router or switch to the RJ-45 LAN connector on the PDU, using an Ethernet cable. You can then monitor the PDU from a workstation or notebook computer that is connected to the same network. For more information about how to monitor the PDU and its output devices through the Web, see “Using the Web interface” on page 33.

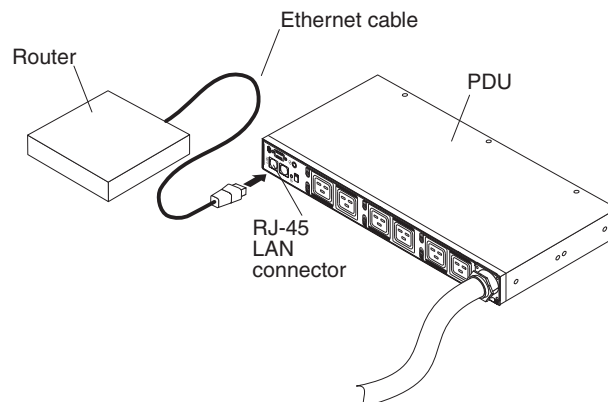

---

## Connecting output devices

The PDU has nine or 12 power outlets for connecting devices such as workstations, servers, and printers. You can monitor the power status of a connected device either manually or remotely through the LAN and console connectors. Connect a device that you want to monitor to a power outlet on the PDU with the power cord that comes with the device.

---

## Connecting an environmental monitoring probe

The environmental monitoring probe that comes with the PDU has a built-in temperature and humidity sensor and enables you to remotely monitor the temperature and humidity of the environment that the PDU is operating in. Connect the environmental monitoring probe to the RJ-45 console connector on the PDU, as shown in the following illustration.

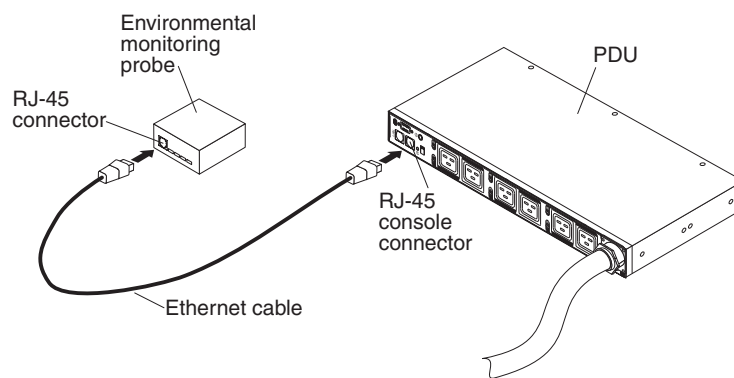

For more information about the environmental monitoring probe, see Chapter 6, "Using the environmental monitoring probe," on page 45.

---

## Chapter 5. Monitoring the power status

You can monitor the power status of any device that is connected to the PDU, either manually or remotely, through the PDU Web interface. You can use the IBM DPI Configuration Utility to initially set up the PDU and to configure PDU settings such as network parameters, access control table, and trap receivers table. You can also use IBM Systems Director Active Energy Manager to monitor power usage of the PDU+ and its load groups.

**Note:** All of the Configuration Utility configuration menu choices are available through the Web interface after the PDU is set up on the local network.

---

### Using the IBM DPI Configuration Utility

This section describes how to use the IBM DPI Configuration Utility to configure the PDU settings, such as the IP address, network parameters, access control table, and trap receivers table.

You can configure the PDU by using a workstation or notebook computer that is connected to the PDU. Connect the DB9-to-RJ-45 cable that comes with the PDU to the RJ-45 console connector on the PDU and to a RS-232 serial (COM) connector on a workstation or notebook computer. For more information, see “Connecting the console” on page 25.

### Using HyperTerminal

HyperTerminal is a terminal program in a Microsoft Windows operating system that you can use to configure or control a device, using command line parameters. You can configure the PDU parameters and its outlets, using numerical commands from a keyboard. You can also use Telnet or any other terminal program to configure the PDU after the IP address is set.

To start HyperTerminal and communicate with the PDU, complete the following steps:

1. To start HyperTerminal, click **Start** → **Programs** → **Accessories** → **Communications** → **HyperTerminal**. The Connection Description window opens.

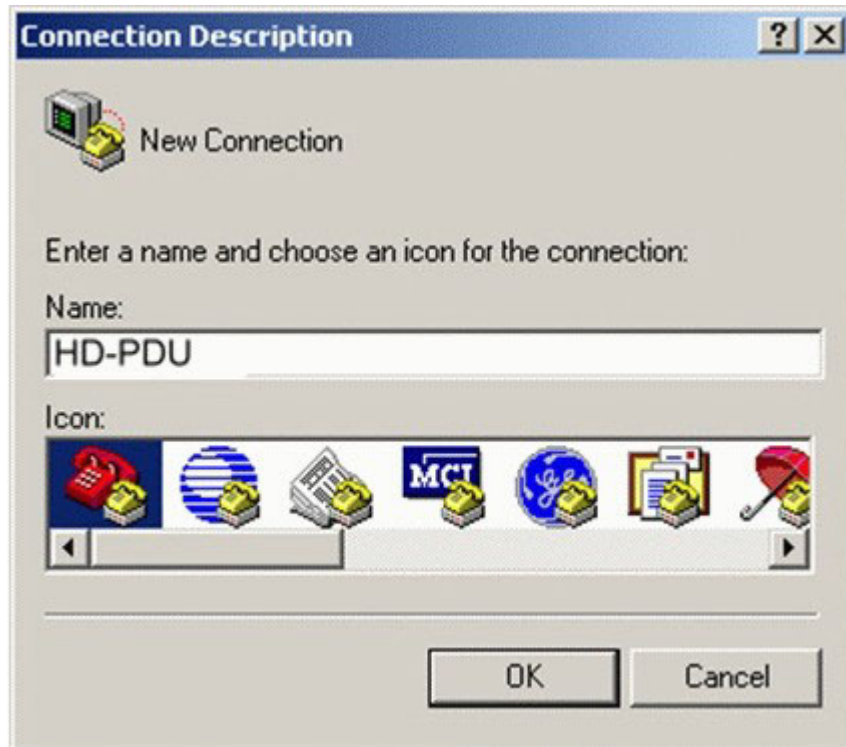

2. In the **Name** field, type the name for the connection and select an icon for the connection. Click **OK**. The Connect To window opens.



3. From the **Connect using** list, select the COM port that is connected to the PDU. Click **OK**. The Properties window opens.

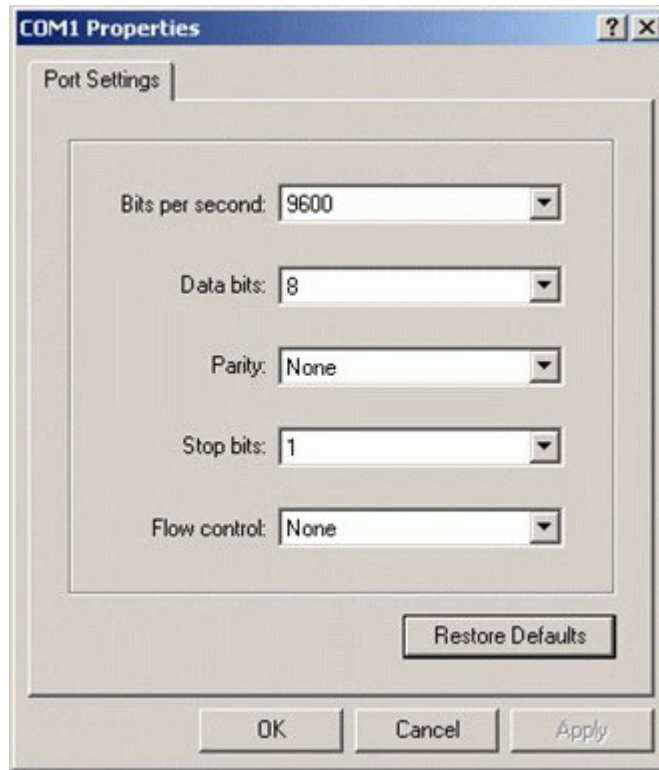

4. Click **Restore Defaults** to use the default settings. Make sure that **9600** is selected in the **Bits per second** list and that **None** is selected in the **Flow control** list. Click **OK**.

5. Press any key. The IBM DPI Configuration Utility main menu opens, and you are prompted for a password. Type passw0rd (all lowercase letters with a zero, not O) and press Enter.

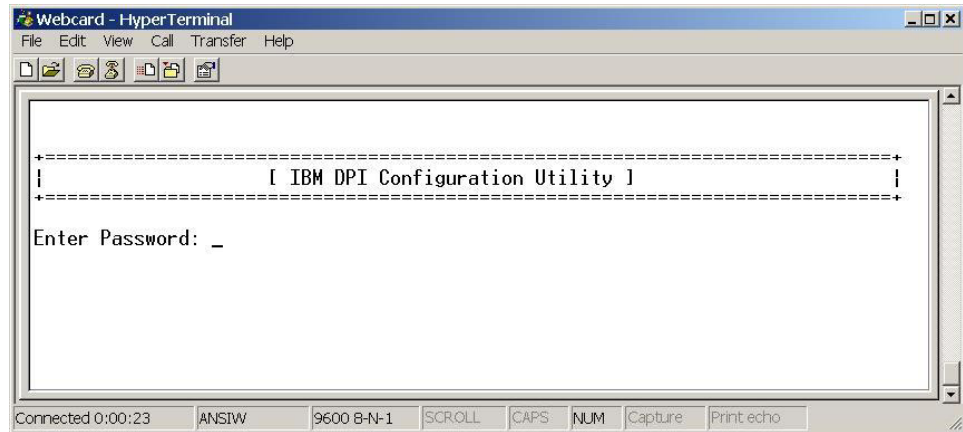

The IBM DPI Configuration Utility main window opens.

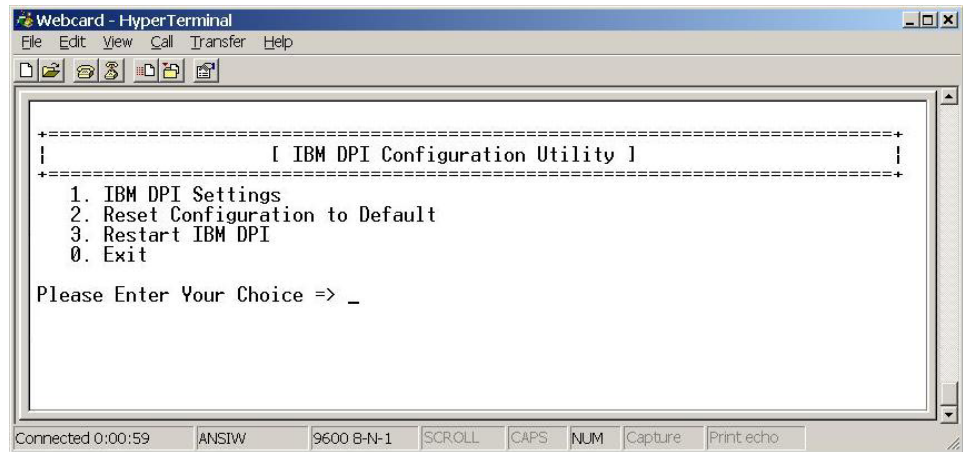

See "Configuration Utility menu choices" on page 31 for descriptions of the choices in this window.



## Configuration Utility menu choices

The following choices are on the Configuration Utility main menu:

- **IBM DPI Settings**

When you select **IBM DPI Settings**, the following window opens.

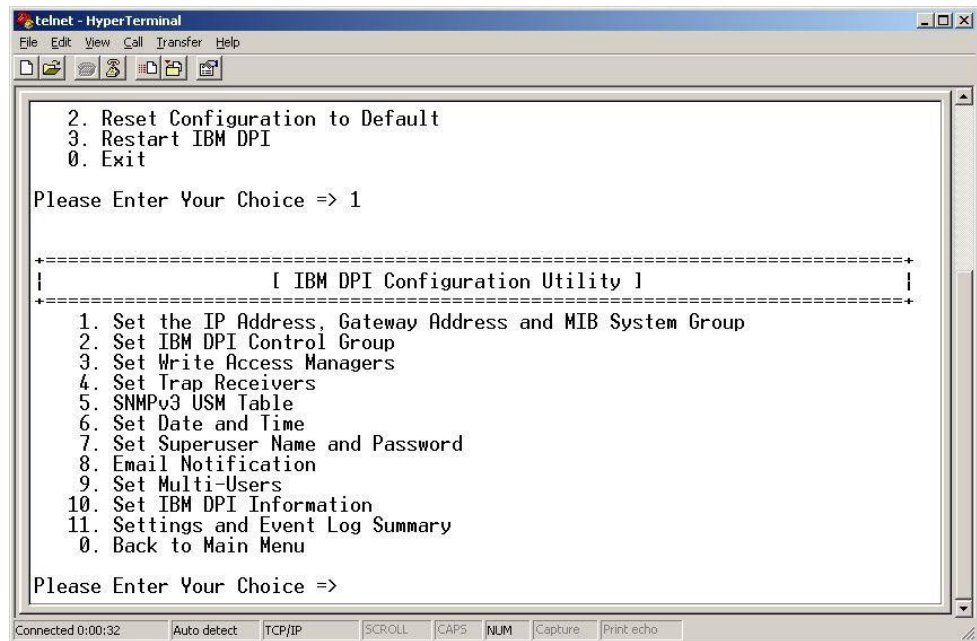

The following choices are available:

- **Set the IP Address, Gateway Address and MIB System Group**  
Select this choice to view and change the IP address, date, time, and MIB system information.
- **Set IBM DPI Control Group**  
Select this choice to set the administrator user name, password, and access protocols.
- **Set Write Access Managers**  
Select this choice to set up a list of users who can access and control the PDU.
- **Set Trap Receivers**  
Select this choice to configure remote network management system (NMS) servers to receive traps.
- **SNMPv3 USM Table**  
Select this choice to set the SNMPv3 USM Table to configure the PDU using SNMPv3 tools.
- **Set Date and Time**  
Select this choice to adjust the date and time information for the PDU.
- **Set Superuser Name and Password**  
Select this choice to set the user name and password of the administrator who will use a Web browser to configure the PDU.
- **E-mail Notification**  
Select this choice to set up a list of users who will be alerted with event messages if an unusual event is triggered on the PDU.

- **Set Multi-Users**  
Select this choice to configure other user and password logins and the read and write access levels.
- **Set IBM DPI Information**  
Select this choice to configure the PDU logging interval, refresh rate, and custom name fields for the load groups.
- **Settings and Event Log Summary**  
Select this choice to view all PDU configuration settings.
- **Reset Configuration to Default**  
Select this choice to reset all PDU settings to their factory default values.
- **Restart HD-PDU**  
Select this choice to restart the PDU.

## Setting the IP address

**Note:** You must set the IP address before you can use the Web interface.

To set the IP address of the PDU, in the Configuration Utility main menu, select **IBM DPI Settings** and then select **Set the IP Address, Gateway Address and MIB System Group**. You must set the IP address before you can access the PDU in an IP network (LAN/WAN). Contact your system administrator if you do not know the IP address.

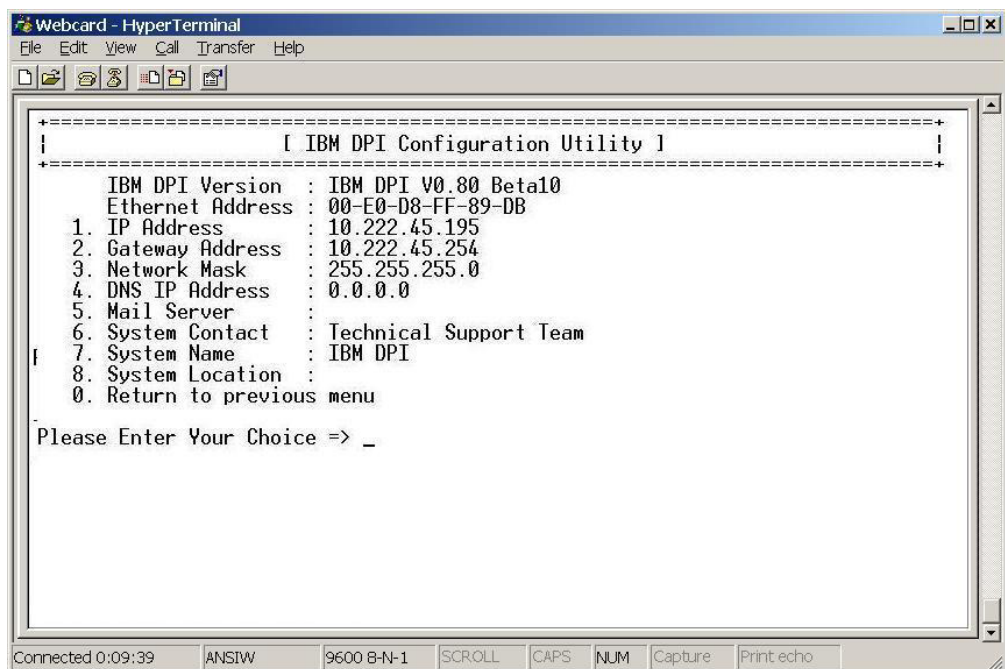

## Using the Web interface

This section provides information about using the Web interface to configure and monitor the PDU remotely. The PDU provides a graphical user interface that you can view from a Web browser. Using a Web browser, you can access and monitor the PDU power outlets and output devices remotely from a workstation or notebook computer.

## Starting the Web interface

To start the Web interface, complete the following steps:

1. Start a Web browser from a workstation or notebook computer and enter the IP address of the PDU in the address field. For more information about setting the IP address of the system, see “Setting the IP address” on page 32.
2. The “Connect to” window opens. In the **User name** field, type USERID (all uppercase letters). In the **Password** field, type passw0rd (all lowercase letters with a zero, not O).
3. Click **OK**. The main status page opens.

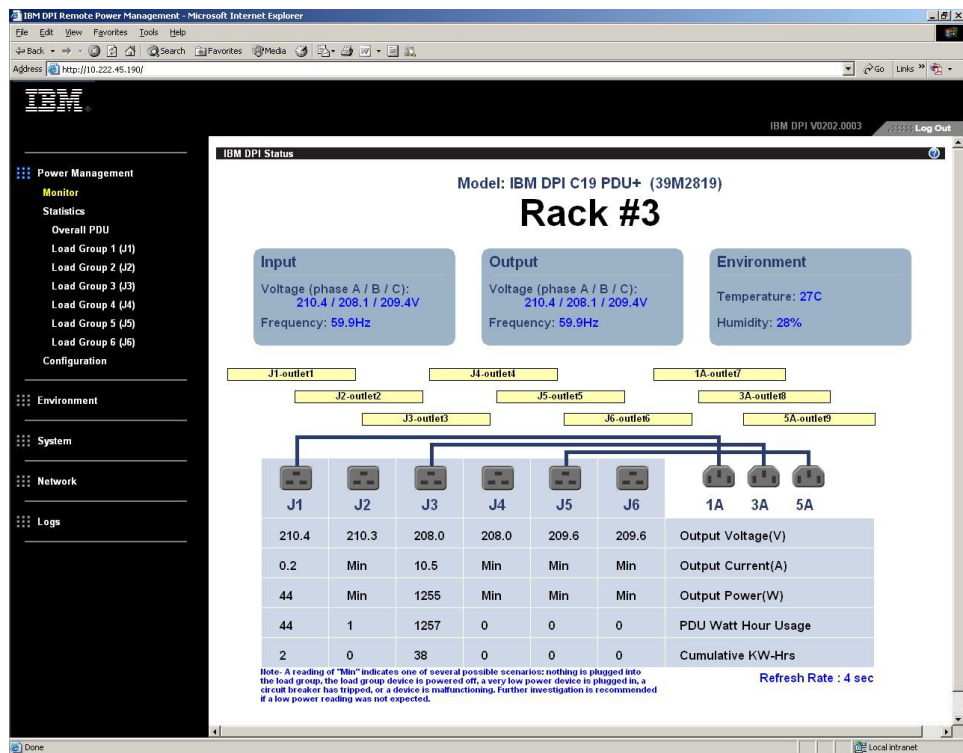

The main page shows a graphical representation of the PDU power outlets and input status:

- The left pane shows the menus and submenus for the PDU. Click a menu to display the menu choices, expand the menu items, and modify the menu choices as required.
- The graphic in the right pane shows the status of the outlets, input voltage, output voltage, frequency, current and power, watt-hour consumption, and cumulative kilowatt hour power consumption. If you connect an optional environmental monitoring probe, the temperature and humidity environment conditions are displayed.

Each menu page provides online help to assist you with configuring the PDU. Click the Help icon at the top of each page to view the help.

## Environment status and configuration

If an environmental monitoring probe is connected to the PDU, you can view the temperature and humidity information. For more information about installing and using the environmental monitoring probe, see Chapter 6, “Using the environmental monitoring probe,” on page 45.

### Viewing the status

On the Status of Environment Sensor page, you can view the environment status (temperature and humidity).

To view the status of an environmental monitoring probe that is connected to the PDU, click **Status** under **Environment**. The Status of Environment Sensor page opens, and the temperature and humidity of the environment sensor are displayed.

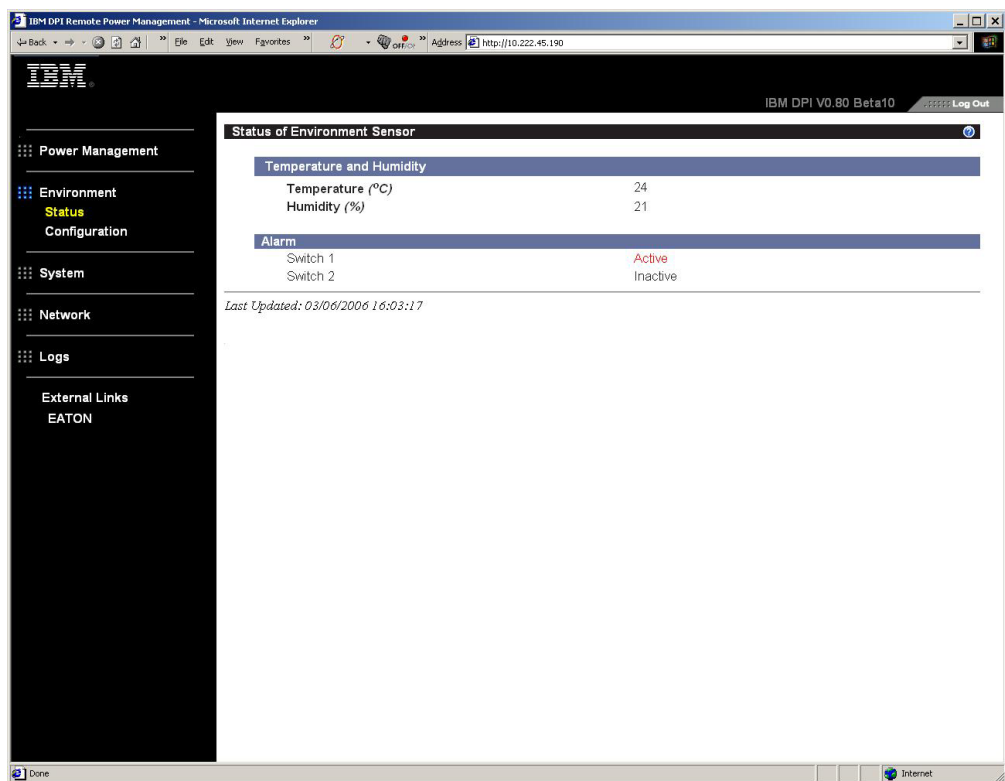

The screenshot shows a web browser window titled "IBM DPI Remote Power Management - Microsoft Internet Explorer". The address bar shows "http://10.222.45.190". The page content includes a navigation menu on the left with categories: Power Management, Environment (with sub-items Status and Configuration), System, Network, and Logs. Below the menu are External Links for EATON. The main content area is titled "Status of Environment Sensor" and contains the following data:

Temperature and Humidity	
Temperature (°C)	24
Humidity (%)	21

Alarm	
Switch 1	Active
Switch 2	Inactive

*Last Updated: 03/06/2006 16:03:17*

## Changing the configuration settings

On the Configuration of Environment Sensor page, you can change the system configuration of the environment sensor.

To configure the environmental monitoring probe that is connected to the PDU, click **Configuration** under **Environment**. You can set the sensor names, high and low set points, and the calibration offsets of the sensors.

The screenshot shows a web browser window titled "IBM DPI Remote Power Management - Microsoft Internet Explorer" with the address bar displaying "http://10.222.45.190". The page content is organized into a sidebar and a main configuration area. The sidebar on the left contains the following menu items: Power Management, Environment (with sub-items Status and Configuration), System, Network, and Logs. Below the sidebar are External Links for EATON. The main content area is titled "Configuration of Environment Sensor" and is divided into three sections: "Configure Temperature", "Configure Humidity", and "Configure Alarm".

Configure Temperature	
Display Degrees	Celsius
Temperature Upper Limit (0 - 70°C)	70
Temperature Lower Limit (0 - 70°C)	0
Temperature Hysteresis (0 - 10°C)	2

Configure Humidity	
Humidity Upper Limit (0 - 90%)	90
Humidity Lower Limit (0 - 90%)	0
Humidity Hysteresis (0 - 20%)	2

Configure Alarm	
Alarm-1 Summary Display Name	Switch 1
Alarm-1 Contact Type	Normally Open
Alarm-2 Summary Display Name	Switch 2
Alarm-2 Contact Type	Normally Closed

## Modifying the basic settings

Use the System menu to configure the PDU system parameters such as the superuser name, password, IP address, date, time, and so on. Some of these settings are described in the following sections.

### Changing the superuser name and password

On the Configuration page, you can set the user name and password of the administrator who will use a Web browser to configure the PDU.

To change the superuser name and password, complete the following steps:

1. From the main status page, in the left navigation pane, click **System**.
2. Click **Configuration** to view and modify the system configuration and superuser user name and password.

The screenshot shows the IBM DPI Remote Power Management web interface in a Microsoft Internet Explorer browser window. The browser title is "IBM DPI Remote Power Management - Microsoft Internet Explorer" and the address bar shows "http://10.222.45.192". The page title is "Configuration of IBM DPI".

The interface features a left navigation pane with the following menu items: Power Management, Environment, System (highlighted), Configuration (highlighted), Identification, Multi-User, Date & Time, Trap Receivers, Email Notification, External Links, Network, and Logs.

The main content area is titled "Configuration of IBM DPI" and contains several sections:

- Configure System:** A table with the following fields:

System Name	BARRMAN's PDU
System Contact	Technical Support Team
System Location	
SNMP Read Community	*****
SNMP Write Community	*****
History Log Interval (Sec)	60
Web Refresh Rate (Sec)	4
- Superuser User Name and Password:** A table with the following fields:

Superuser User Name	USERID
Superuser Password	*****
Confirm Superuser Password	*****
- Control:** Two buttons: "Reset to Default" and "Restart System".
- Upload & Download:** A "Download Configuration" button, an "Upload Configuration" button, and a "Browse..." button next to a file input field.

At the bottom of the page, there is a "Log Out" link and an "Internet" icon in the status bar.

## Identifying the PDU and Web/SNMP card

On the Identification of Power Management page, you can view the PDU and Web/SNMP card information.

To view the power management information of the PDU and Web/SNMP card, complete the following steps:

1. From the main status page, in the left navigation pane, click **System**.
2. Click **Identification** to view the PDU and Web/SNMP card information.

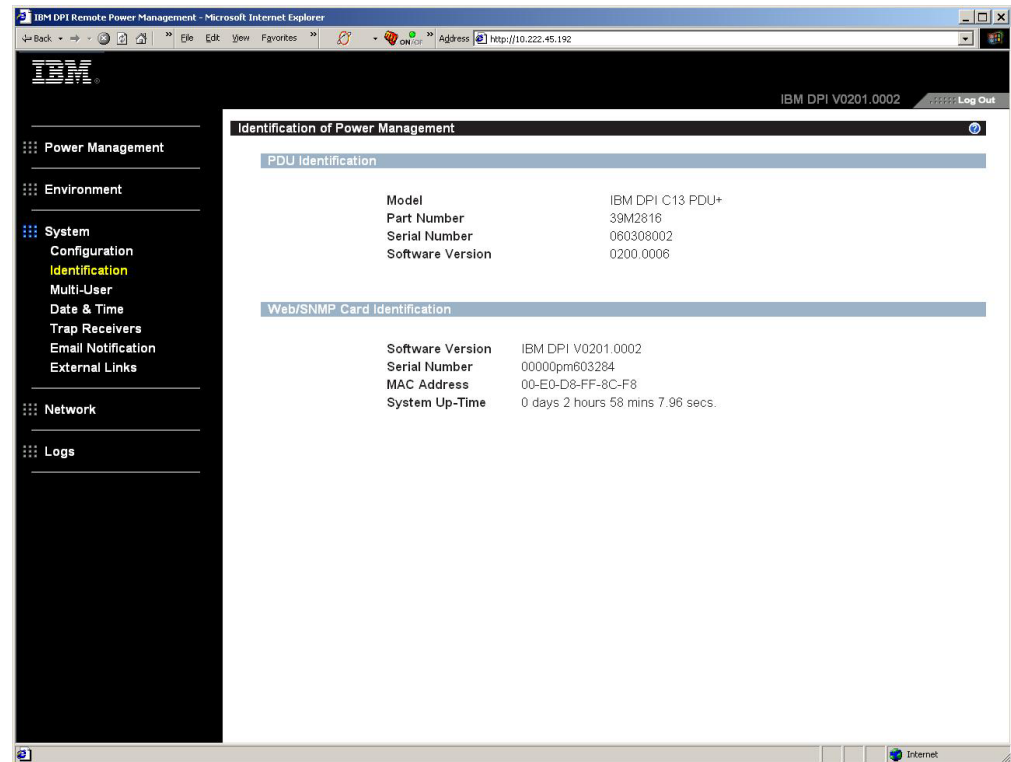

## Adding users

On the Multi-User Configuration page, you can add users who can access and control the PDU.

To create a list of users who can access and control the PDU, complete the following steps:

1. From the main status page, in the left navigation pane, click **System**.
2. Click **Multi-User**. You can add users who can only view the PDU status or users who can change the PDU settings.

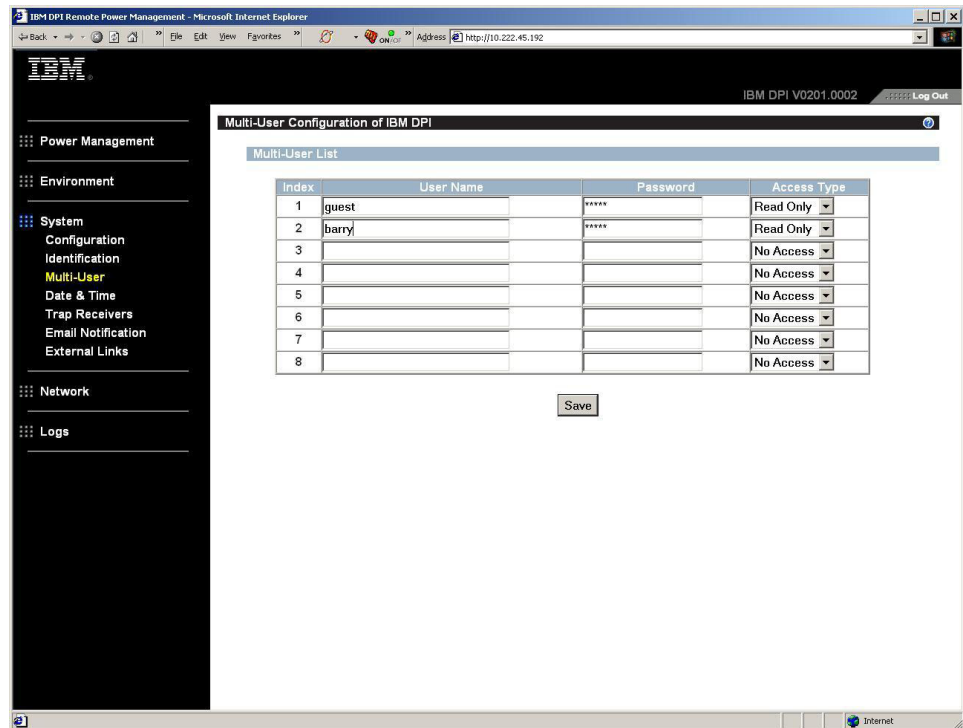



## Changing the date and time

On the Date and Time page, you can change the date and time of the PDU.

**Note:** Changing the PDU date and time affects other PDU settings such as e-mail, traps, and logs.

To change the date and time, complete the following steps:

1. From the main status page, in the left navigation pane, click **System**.
2. Click **Date and Time** to view and modify the system date and time. You can set the date and time manually, synchronize it with the computer time, or synchronize it with an NTP server.

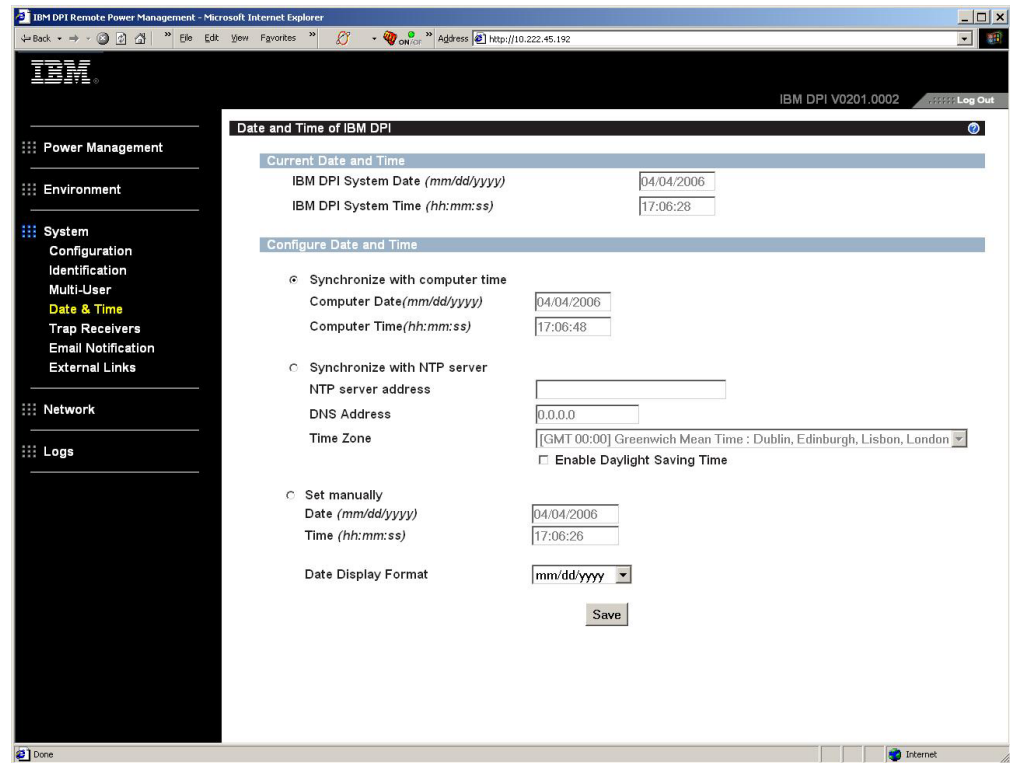

## Changing event alerts

On the SNMP Trap Receivers page, you can change event alerts.

To configure the PDU to send e-mail or SNMP trap alerts to specified users when specific events occur, complete the following steps:

1. From the main status page, in the left navigation pane, click **System**.
2. Click **Trap Receivers** to create a list of users or workstations who will be alerted with an SNMP trap message. You can specify the IP addresses of up to eight trap receivers, the community information, type of trap, severity of trap, and description of the events that cause the traps.

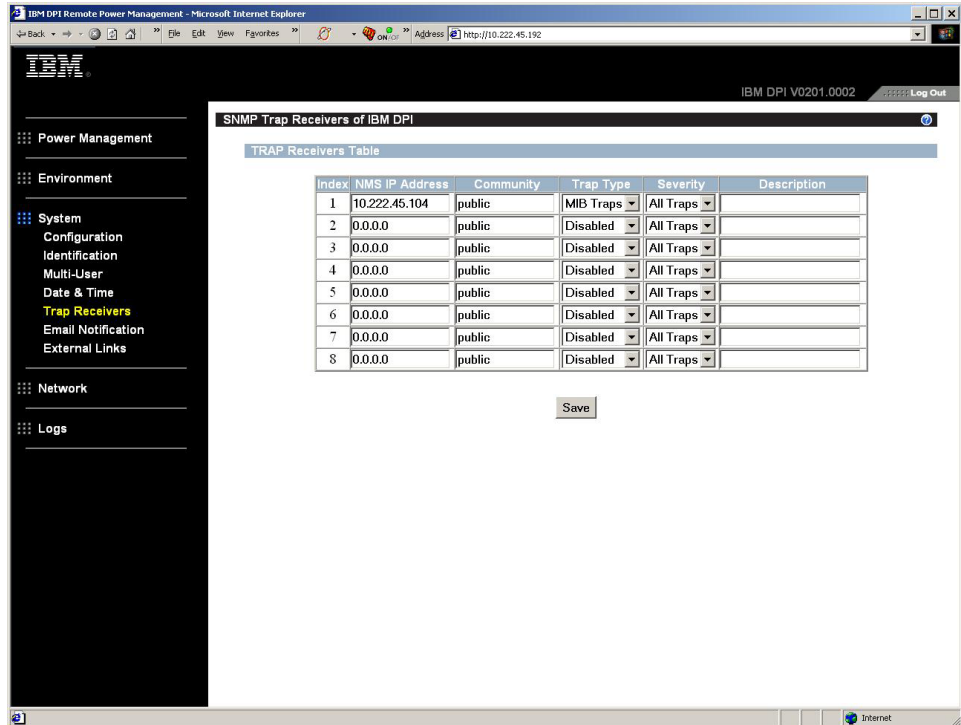

IBM DPI Remote Power Management - Microsoft Internet Explorer

IBM DPI V0201.0002 Log Out

SNMP Trap Receivers of IBM DPI

TRAP Receivers Table

Index	NMS IP Address	Community	Trap Type	Severity	Description
1	10.222.45.104	public	MIB Traps	All Traps	
2	0.0.0.0	public	Disabled	All Traps	
3	0.0.0.0	public	Disabled	All Traps	
4	0.0.0.0	public	Disabled	All Traps	
5	0.0.0.0	public	Disabled	All Traps	
6	0.0.0.0	public	Disabled	All Traps	
7	0.0.0.0	public	Disabled	All Traps	
8	0.0.0.0	public	Disabled	All Traps	

Save

3. Click **Email Notification** under **System** to create a list of up to four users who will be alerted with an e-mail. Use this menu to specify the mail server, user account, DNS, and other information that is necessary to set up a mail server for sending mail alerts. Use the Email Receivers Table to add the e-mail addresses.

IBM DPI Remote Power Management - Microsoft Internet Explorer

Address: http://10.222.45.192

IBM DPI V0201.0002 Log Out

**Email Notification of IBM DPI**

**Email Configuration**

Mail Server:

DNS Address: 0.0.0.0

Optional SMTP Username:

Optional SMTP Password:

Sender's Email Address: IBM\_DPI@10.222.45.192

SMTP Reply to Address: IBM\_DPI@10.222.45.192

SMTP Port Number: 25

**Email Receivers Table**

Index	Mail Account	Description	Mail Type	Event Level	Mail Daily Report Hour
1	<input type="text"/>	<input type="text"/>	None	All	00:00
2	<input type="text"/>	<input type="text"/>	None	All	18:00
3	<input type="text"/>	<input type="text"/>	None	All	00:00
4	<input type="text"/>	<input type="text"/>	None	All	00:00

Save Send Test

## Changing the network information

Use the Network menu to change the network information for the PDU, for example, the IP address.

## Changing the network configuration

To view or change the network configuration of the PDU, under **Network**, click **Configuration**. You can set the PDU IP address, gateway address, subnet mask, and Domain Name System (DNS) address.

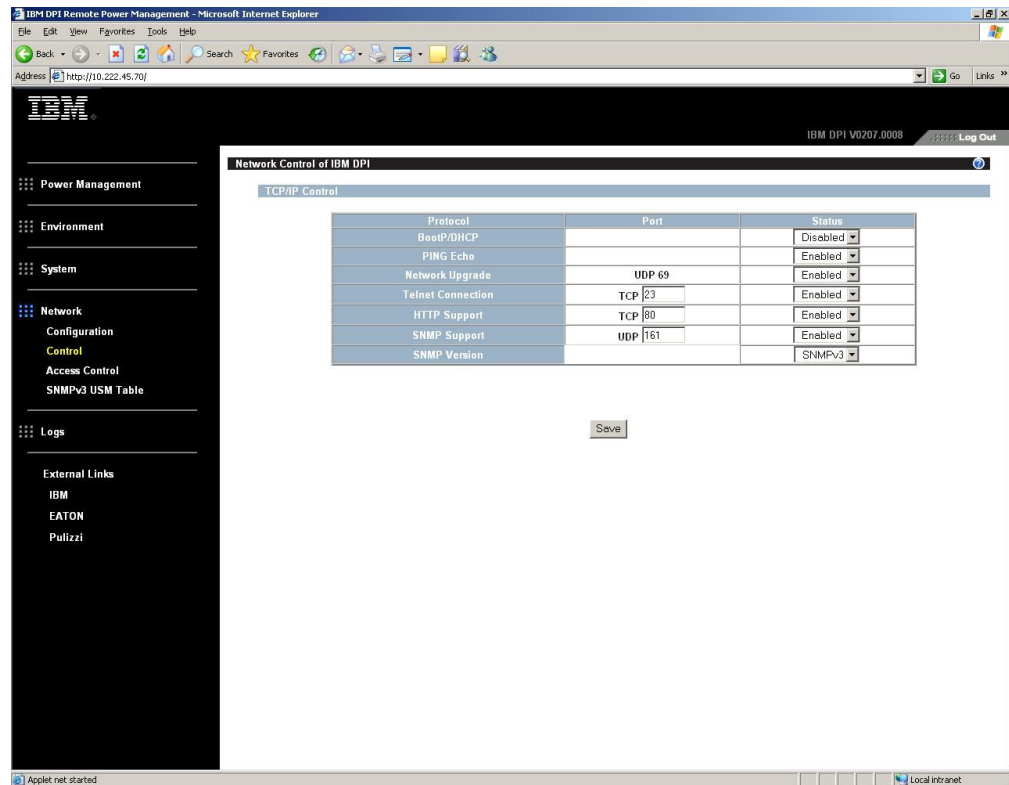

Click **Control** under **Network** to configure TCP/IP settings.

Click **Access Control** under **Network** to set access control to prevent unauthorized users from accessing the PDU.

Click **SNMPv3 USM Table** to configure SNMPv3 settings.

## History and event log summaries

The Logs menu provides a detailed description of all events and a record of the PDU status. System administrators can use this page to analyze problems with network equipment.

### Viewing the history log

On the History Log page, you can view the complete history of the PDU inputs, outputs, and environmental monitoring probe.

To view the history of the PDU, under **Logs**, click **History**. Each log file shows a record of the input power, output power of each outlet, and environmental monitoring probe temperature and humidity.

History Log of HD-PDU																		
Log Date (yyyy-mm-dd)	Log Time (hh:mm:ss)	Input						Output									EMP	
		Frequency (Hz)	Voltage A (V)	Voltage B (V)	Voltage C (V)	Frequency (Hz)	Voltage A (V)	Voltage B (V)	Voltage C (V)	Current A (V)	Current B (V)	Current C (V)	True Power A (V)	True Power B (V)	True Power C (V)	Temperature (C)	Humidity (%)	
2006-01-12	07:30:00	60.0	101.5	24.8	24.1	60.0	101.5	24.8	24.1	0.1	0.0	0.0	0	0	0	28	36	
2006-01-12	07:30:30	60.0	101.5	24.8	24.1	60.0	101.6	24.8	24.1	0.1	0.0	0.0	0	0	0	28	36	
2006-01-12	07:31:00	59.8	101.5	24.8	24.1	59.8	101.5	24.8	24.1	0.1	0.0	0.0	0	0	0	28	36	
2006-01-12	07:31:30	59.8	101.5	24.8	24.1	59.8	101.5	24.8	24.1	0.1	0.0	0.0	0	0	0	28	36	
2006-01-12	07:32:00	60.0	101.5	24.8	24.1	60.0	101.5	24.8	24.1	0.1	0.0	0.0	0	0	0	28	36	

### Viewing the event log

On the Event Log page, you can view the complete record of the PDU events.

To view the complete record of the PDU events, under **Logs**, click **Event**. Each event log file shows the time, date, and description of all the events that have occurred on the PDU.

Event Log of HD-PDU		
Date(yyyy-mm-dd)	Time(hh:mm:ss)	Event Description
2006-01-06	16:34:43	Date and Time change made by RTC
2006-01-06	16:34:45	HD-PDU Warm Boot
2006-01-06	16:34:53	External Contact Monitoring Cable Installed
2006-01-06	16:34:53	External Contact #1 Status Monitoring Enabled
2006-01-06	16:34:53	External Contact #2 Status Monitoring Enabled
2006-01-06	16:35:29	Communication with UPS/PDU restored
2006-01-06	16:43:24	Parameters reset to default
2006-01-06	16:43:25	External Contact #1 Status Monitoring Disabled
2006-01-06	16:43:25	External Contact #2 Status Monitoring Disabled
2006-01-06	16:47:33	HD-PDU Adapter Restart



---

## Chapter 6. Using the environmental monitoring probe

**Note:** The environmental monitoring probe comes with the PDU+ models, except the DPI C13 3-phase PDU+. For the DPI C13 3-phase PDU+, you can order the environmental monitoring probe at the time of purchase.

The environmental monitoring probe is a connectivity device that enables you to remotely monitor the temperature, humidity, and status of two contact devices through a standard Web browser, providing greater power management control and flexible monitoring.

You can use the environmental monitoring probe with any IBM DPI PDU+ models.

When the environmental monitoring probe is connected to the RJ-45 console connector on the PDU, temperature and humidity readings are automatically displayed in the Web interface. To access the readings, you must run the Web browser and connect to the PDU IP address.

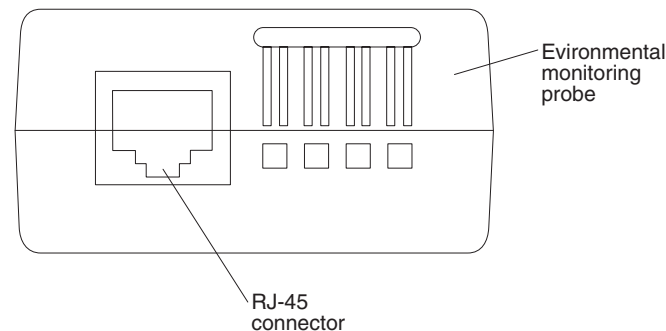

---

### Features

The environmental monitoring probe has the following features:

- The hot-swap feature simplifies installation by enabling you to install the probe safely without turning off power to the PDU or to the loads that are connected to it.
- It monitors temperature and humidity information of any environment that you want to protect your critical equipment.
- It measures temperatures between 0 and 80°C (32 and 176°F) with an accuracy of  $\pm 1^\circ\text{C}$ .
- It measures relative humidity between 10 and 90% with an accuracy of  $\pm 5\%$ .
- It can be located away from the PDU with a CAT5 network cable up to 20 m (65.6 ft) long.
- It monitors the status of the two user-provided contact devices.
- Temperature, humidity, and contact closure status can be displayed through a Web browser.
- User-selectable alarm thresholds enable you to define acceptable temperature or humidity limits
- E-mail notification through Simple Mail Transfer Protocol (SMTP), using e-mail client software when acceptable alarm limits are exceeded or contact status changes.

- Changes in contact closure status are logged in the PDU event history log.
- When temperature and humidity values exceed user-selectable limits, the event is logged in the PDU event history log.

## Installing the environmental monitoring probe

To install the environmental monitoring probe, complete the following steps:

1. If applicable, connect external contact closure inputs to the screw terminals on the environmental monitoring probe.

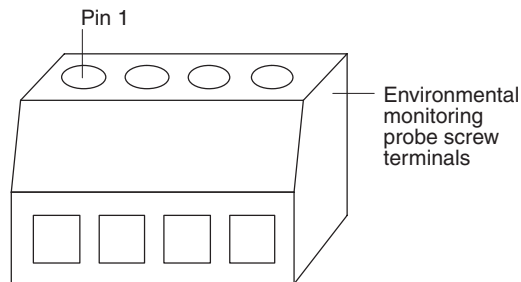

**Note:** Contact closure device 1 is connected between pins 1 and 2. Device 2 is connected between pins 3 and 4 (as labeled to show device 1 and 2). Contact closure devices can be normally open or normally closed.

Table 3. Environmental monitoring probe screw terminal pin assignment

Pin number	Description	Normally open/ normally closed
1	Contact 1 return	Normally closed
2	Contact 1 signal input	Normally open
3	Contact 2 return	Normally closed
4	Contact 2 signal input	Normally open

2. Connect the CAT5 network cable that comes with the PDU to the environmental monitoring probe RJ-45 connector and to the RJ-45 console connector on the PDU.

**Note:** If the cable is not long enough for your configuration, you can use a cable that is 20 m (65.6 ft) or less.

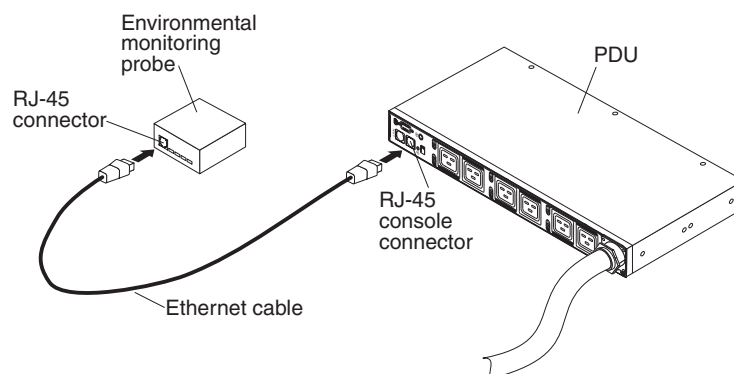

3. Make sure that the PDU has a network connection, the power cord is connected, and the power to the PDU is turned on. The environmental monitoring probe is automatically recognized by the PDU.



4. Start a Web browser and connect to the PDU IP address (for more information, see “Using the Web interface” on page 33). The Web interface main status page opens. Click **Environment**, and then click **Status**. The Status of Environment Sensor page opens. The temperature and humidity status is automatically displayed.

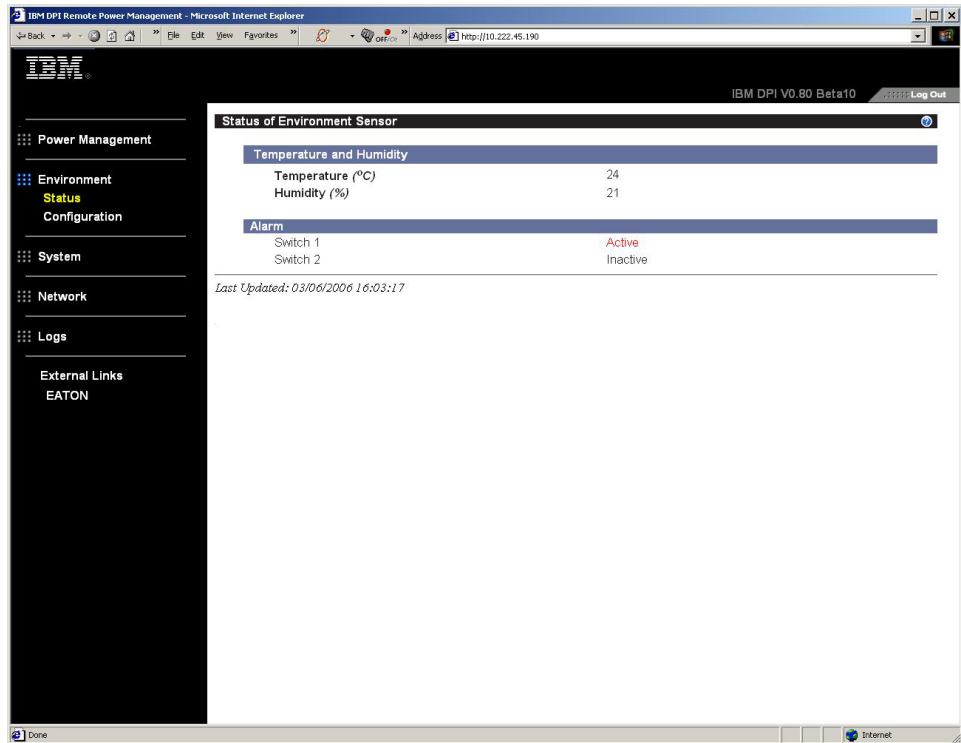

5. Before the status of the contact closures is displayed, you must configure and enable this feature on the PDU Web interface. Click **Environment**, and then click **Configuration**. The Configuration of Environment Sensor page opens.

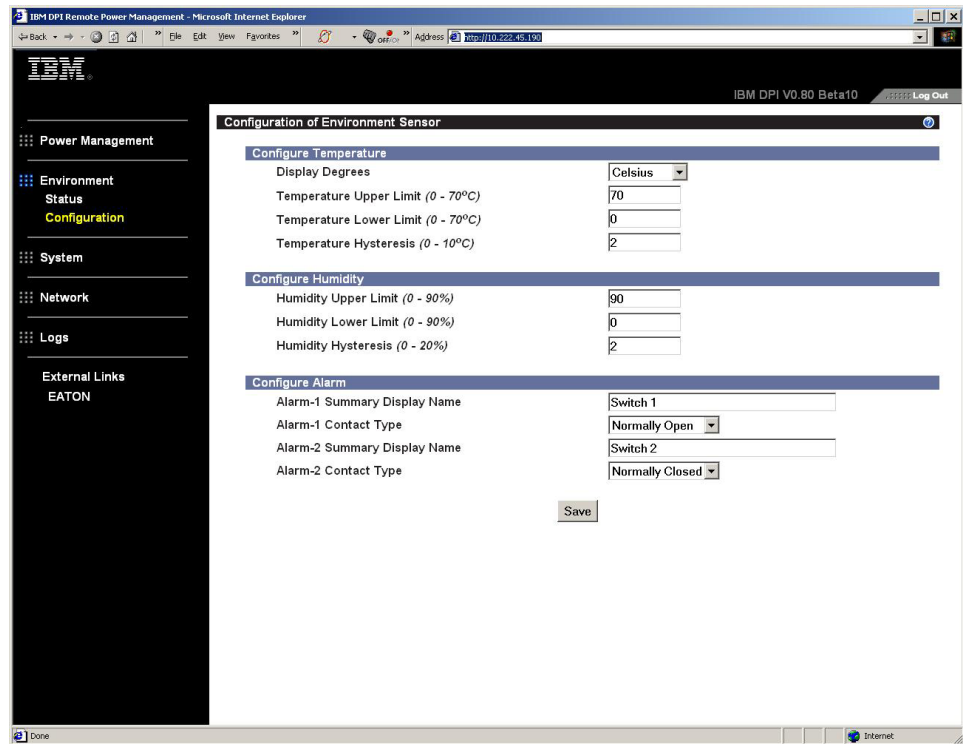

You can configure and enable both contacts and set upper and lower ranges of temperature and humidity that will generate SNMP traps and e-mail notification if the PDU is configured to do so.

## Chapter 7. Customer replaceable unit parts

Replaceable components are of three types:

- **Tier 1 customer replaceable unit (CRU):** Replacement of Tier 1 CRUs is your responsibility. If IBM installs a Tier 1 CRU at your request, you will be charged for the installation.
- **Tier 2 customer replaceable unit:** You may install a Tier 2 CRU yourself or request IBM to install it, at no additional charge, under the type of warranty service that is designated for your server.
- **Field replaceable unit (FRU):** FRUs must be installed only by trained service technicians.

For information about the terms of the warranty and getting service and assistance, see Appendix B, “IBM Statement of Limited Warranty Z125-4753-08 04/2004,” on page 57.

**Important:** The PDU does not contain any serviceable parts.

PDU description	PDU Tier 1 CRU part number	Power cord Tier 1 CRU part number
DPI 32 amp/250 V 1-phase Enterprise C13 PDU+ with IEC 309 2P+N+Gnd connector	40K9637	39M5428
DPI 60 amp/208 V 1-phase Enterprise C13 PDU+ with IEC 309 2P+Gnd connector	40K9637	39M5431
DPI 63 amp/250 V 1-phase Enterprise C13 PDU+ with IEC 309 2P+N+Gnd connector	40K9637	39M5429
DPI 32 amp/250 V 3-phase Enterprise C13 PDU+ with IEC 309 3P+N+Gnd connector	40K9637	39M5427
DPI 30 amp/208 V 1-phase Enterprise C13 PDU+ with Nema L6-30P connector	40K9637	39M5430
DPI 60 amp/208 V 3-phase Enterprise C13 PDU+ with IEC 309 3P+Gnd connector	43V5995	Cord comes attached to PDU
DPI 60 amp/208 V 1-phase Enterprise C19 PDU+ with IEC 309 2P+Gnd connector	40K9638	39M5431
DPI 63 amp/250 V 1-phase Enterprise C19 PDU+ with IEC 309 2P+N+Gnd connector	40K9638	39M5429
DPI 32 amp/250 V 3-phase Enterprise C19 PDU+ with IEC 309 3P+N+Gnd connector	40K9638	39M5427
DPI 60 amp/208 V 3-phase Enterprise C19 PDU+ with IEC 309 3P+Gnd connector	40K9639	Cord comes attached to PDU
Environmental monitoring probe kit	41Y9210	
Mounting hardware kit	41Y9284	
DB9-to-RJ-45 cable	40K9640	



## Chapter 8. PDU specifications

The following table contains the product specifications of the PDUs. The PDUs in the following list correspond by number to the rated voltages, maximum power ratings, and power cords that are listed in the table:

1. DPI 32 amp/250 V 1-phase Enterprise C13 PDU+ with IEC 309 2P+N+Gnd connector
2. DPI 60 amp/208 V 1-phase Enterprise C13 PDU+ with IEC 309 2P+Gnd connector
3. DPI 63 amp/250 V 1-phase Enterprise C13 PDU+ with IEC 309 2P+N+Gnd connector
4. DPI 32 amp/250 V 3-phase Enterprise C13 PDU+ with IEC 309 3P+N+Gnd connector
5. DPI 30 amp/208 V 1-phase Enterprise C13 PDU+ with Nema L6-30P connector
6. DPI 60 amp/208 V 3-phase Enterprise C13 PDU+ with IEC 309 3P+Gnd connector
7. DPI 60 amp/208 V 1-phase Enterprise C19 PDU+ with IEC 309 2P+Gnd connector
8. DPI 63 amp/250 V 1-phase Enterprise C19 PDU+ with IEC 309 2P+N+Gnd connector
9. DPI 32 amp/250 V 3-phase Enterprise C19 PDU+ with IEC 309 3P+N+Gnd connector
10. DPI 60 amp/208 V 3-phase Enterprise C19 PDU+ with IEC 309 3P+Gnd connector

<b>Height</b>	43.9 mm (1.73 in.)
<b>Width</b>	447 mm (17.6 in.)
<b>Depth</b>	350 mm (13.78 in.)
<b>Additional clearance</b>	25 mm (0.98 in.) for circuit breakers 3 mm (0.12 in.) for outlets
<b>Weight (not including power cord)</b>	6.3 kg (13.8 lb)
<b>Weight of power cord (approximate, varies by PDU model)</b>	5.4 kg (11.8 lb)
<b>Operating temperature at 0 - 914 m (0 - 3000 ft) (room ambient)</b>	10°- 35°C (50°- 95°F)
<b>Operating temperature at 914 -2133 m (3000 - 7000 ft) (room ambient)</b>	10°- 32°C (50°- 90°F)
<b>Operating humidity</b>	8 - 80% (noncondensing)
<b>Localized air temperature in PDU</b>	60°C (140°F) maximum

<b>Rated voltage</b>	<ol style="list-style-type: none"> <li>1. 220 - 240 V ac, 32 amps, single-phase</li> <li>2. 200 - 208 V ac, 48 amps, single-phase</li> <li>3. 220 - 240 V ac, 63 amps, single-phase</li> <li>4. 220 - 240 V ac, 32 amps, three-phase Wye</li> <li>5. 200 - 208 V ac, 24 amps, single-phase</li> <li>6. 200 - 208 V ac, 48 amps, three-phase Delta</li> <li>7. 200 - 208 V ac, 48 amps, single-phase</li> <li>8. 220 - 240 V ac, 63 amps, single-phase</li> <li>9. 220 - 240 V ac, 32 amps, three-phase Wye</li> <li>10. 200 - 208 V ac, 48 amps, three-phase Delta</li> </ol>
<b>Rated frequency</b>	50-60 Hz
<b>Maximum power rating</b>	<ol style="list-style-type: none"> <li>1. 7680 VA</li> <li>2. 9984 VA</li> <li>3. 15120 VA</li> <li>4. 23040 VA</li> <li>5. 4992 VA</li> <li>6. 17292 VA</li> <li>7. 9984 VA</li> <li>8. 15120 VA</li> <li>9. 23040 VA</li> <li>10. 17292 VA</li> </ol>
<b>Circuit breakers</b>	Six double-pole branch rated circuit breakers rated at 20 amps
<b>Power cord</b>	<ol style="list-style-type: none"> <li>1. One IEC 309 2P+N+Gnd connector rated at 32 amps</li> <li>2. One IEC 309 2P+Gnd connector rated at 60 amps</li> <li>3. One IEC 309 2P+N+Gnd connector rated at 63 amps</li> <li>4. One IEC 309 3P+N+Gnd connector rated at 32 amps</li> <li>5. One Nema L6-30P connector rated at 30 amps</li> <li>6. One IEC 309 3P+Gnd connector rated at 60 amps</li> <li>7. One IEC 309 2P+Gnd connector rated at 60 amps</li> <li>8. One IEC 309 2P+N+Gnd connector rated at 63 amps</li> <li>9. One IEC 309 3P+N+Gnd connector rated at 32 amps</li> <li>10. One IEC 309 3P+Gnd connector rated at 60 amps</li> </ol>
<b>Power outlets</b>	<p>Six IEC 320-C19 outlets rated at 16 amps (VDE) / 20 amps (UL/CSA)</p> <p>Twelve IEC 320-C13 outlets rated at 10 amps (VDE) / 15 amps (UL/CSA)</p>

You must connect the connector on the power cord that comes with your PDU to a properly wired and grounded outlet. The following table shows illustrations of the power cord connector and the correct outlet for each of the PDUs.

PDU	Plug	Outlet	Rating
<ul style="list-style-type: none"> <li>DPI 32 amp/250 V 3-phase Enterprise C13 PDU with IEC 309 3P+N+Gnd connector</li> <li>DPI 32 amp/250 V 3-phase Enterprise C19 PDU with IEC 309 3P+N+Gnd connector</li> </ul>			32 amps, 220-240/380-415 V ac IEC 309 3P+N+Gnd
<ul style="list-style-type: none"> <li>DPI 32 amp/250 V 1-phase Enterprise C13 PDU with IEC 309 2P+N+Gnd connector</li> </ul>			32 amps, 250 V ac IEC 309 P+N+Gnd
<ul style="list-style-type: none"> <li>DPI 63 amp/250 V 1-phase Enterprise C13 PDU with IEC 309 2P+N+Gnd connector</li> <li>DPI 63 amp/250 V 1-phase Enterprise C19 PDU with IEC 309 2P+N+Gnd connector</li> </ul>			63 amps, 250 V ac IEC 309 3P+N+Gnd
<ul style="list-style-type: none"> <li>DPI 30 amp/208 V 1-phase Enterprise C13 PDU with Nema L6-30P connector</li> </ul>			30 amps, 250 V ac NEMA L6-30
<ul style="list-style-type: none"> <li>DPI 60 amp/208 V 1-phase Enterprise C13 PDU with IEC 309 2P+Gnd connector</li> <li>DPI 60 amp/208 V 1-phase Enterprise C19 PDU with IEC 309 2P+Gnd connector</li> </ul>			60 amps, 250 V ac IEC 309 2P+Gnd
<ul style="list-style-type: none"> <li>DPI 60 amp/208 V 3-phase Enterprise C19 PDU with IEC 309 3P+Gnd connector</li> <li>DPI 60 amp/208 V 3-phase Enterprise C13 PDU with IEC 3P+Gnd connector</li> </ul>			60 amps, 208 V ac IEC 309 3P+Gnd





---

## Appendix A. Getting help and technical assistance

If you need help, service, or technical assistance or just want more information about IBM products, you will find a wide variety of sources available from IBM to assist you. This section contains information about where to go for additional information about IBM and IBM products, what to do if you experience a problem with your system, and whom to call for service, if it is necessary.

---

### Before you call

Before you call, make sure that you have taken these steps to try to solve the problem yourself:

- Check all cables to make sure that they are connected.
- Check the power switches to make sure that the system and any optional devices are turned on.
- Use the troubleshooting information in your system documentation, and use the diagnostic tools that come with your system. Information about diagnostic tools is in the *Problem Determination and Service Guide* on the *IBM Documentation CD* that comes with your system.
- Go to the IBM support Web site at <http://www.ibm.com/systems/support/> to check for technical information, hints, tips, and new device drivers or to submit a request for information.

You can solve many problems without outside assistance by following the troubleshooting procedures that IBM provides in the online help or in the documentation that is provided with your IBM product. The documentation that comes with IBM systems also describes the diagnostic tests that you can perform. Most systems, operating systems, and programs come with documentation that contains troubleshooting procedures and explanations of error messages and error codes. If you suspect a software problem, see the documentation for the operating system or program.

---

### Using the documentation

Information about your IBM system and preinstalled software, if any, or optional device is available in the documentation that comes with the product. That documentation can include printed documents, online documents, readme files, and help files. See the troubleshooting information in your system documentation for instructions for using the diagnostic programs. The troubleshooting information or the diagnostic programs might tell you that you need additional or updated device drivers or other software. IBM maintains pages on the World Wide Web where you can get the latest technical information and download device drivers and updates. To access these pages, go to <http://www.ibm.com/systems/support/> and follow the instructions. Also, some documents are available through the IBM Publications Center at <http://www.ibm.com/shop/publications/order/>.

---

### Getting help and information from the World Wide Web

On the World Wide Web, the IBM Web site has up-to-date information about IBM systems, optional devices, services, and support. The address for IBM System x™ and xSeries® information is <http://www.ibm.com/systems/x/>. The address for IBM BladeCenter® information is <http://www.ibm.com/systems/bladecenter/>. The address for IBM IntelliStation® information is <http://www.ibm.com/intellistation/>.

You can find service information for IBM systems and optional devices at <http://www.ibm.com/systems/support/>.

---

## Software service and support

Through IBM Support Line, you can get telephone assistance, for a fee, with usage, configuration, and software problems with System x and xSeries servers, BladeCenter products, IntelliStation workstations, and appliances. For information about which products are supported by Support Line in your country or region, see <http://www.ibm.com/services/sl/products/>.

For more information about Support Line and other IBM services, see <http://www.ibm.com/services/>, or see <http://www.ibm.com/planetwide/> for support telephone numbers. In the U.S. and Canada, call 1-800-IBM-SERV (1-800-426-7378).

---

## Hardware service and support

You can receive hardware service through IBM Services or through your IBM reseller, if your reseller is authorized by IBM to provide warranty service. See <http://www.ibm.com/planetwide/> for support telephone numbers, or in the U.S. and Canada, call 1-800-IBM-SERV (1-800-426-7378).

In the U.S. and Canada, hardware service and support is available 24 hours a day, 7 days a week. In the U.K., these services are available Monday through Friday, from 9 a.m. to 6 p.m.

---

## IBM Taiwan product service

台灣 IBM 產品服務聯絡方式：  
台灣國際商業機器股份有限公司  
台北市松仁路7號3樓  
電話：0800-016-888

IBM Taiwan product service contact information:

IBM Taiwan Corporation  
3F, No 7, Song Ren Rd.  
Taipei, Taiwan  
Telephone: 0800-016-888

---

# Appendix B. IBM Statement of Limited Warranty Z125-4753-08 04/2004

---

## Part 1 - General Terms

### Part 1 - General Terms

*This Statement of Limited Warranty includes Part 1 - General Terms, Part 2 - Country-unique Terms, and Part 3 - Warranty Information. The terms of Part 2 replace or modify those of Part 1. The warranties provided by IBM in this Statement of Limited Warranty apply only to Machines you purchase for your use, and not for resale. The term "Machine" means an IBM machine, its features, conversions, upgrades, elements, or accessories, or any combination of them. The term "Machine" does not include any software programs, whether pre-loaded with the Machine, installed subsequently or otherwise. **Nothing in this Statement of Limited Warranty affects any statutory rights of consumers that cannot be waived or limited by contract.***

### What this Warranty Covers

IBM warrants that each Machine 1) is free from defects in materials and workmanship and 2) conforms to IBM's Official Published Specifications ("Specifications") which are available on request. The warranty period for the Machine starts on the original Date of Installation and is specified in Part 3 - Warranty Information. The date on your invoice or sales receipt is the Date of Installation unless IBM or your reseller informs you otherwise. Many features, conversions, or upgrades involve the removal of parts and their return to IBM. A part that replaces a removed part will assume the warranty service status of the removed part. Unless IBM specifies otherwise, these warranties apply only in the country or region in which you purchased the Machine.

**THESE WARRANTIES ARE YOUR EXCLUSIVE WARRANTIES AND REPLACE ALL OTHER WARRANTIES OR CONDITIONS, EXPRESS OR IMPLIED, INCLUDING, BUT NOT LIMITED TO, THE IMPLIED WARRANTIES OR CONDITIONS OF MERCHANTABILITY AND FITNESS FOR A PARTICULAR PURPOSE. SOME STATES OR JURISDICTIONS DO NOT ALLOW THE EXCLUSION OF EXPRESS OR IMPLIED WARRANTIES, SO THE ABOVE EXCLUSION MAY NOT APPLY TO YOU. IN THAT EVENT, SUCH WARRANTIES ARE LIMITED IN DURATION TO THE WARRANTY PERIOD. NO WARRANTIES APPLY AFTER THAT PERIOD. SOME STATES OR JURISDICTIONS DO NOT ALLOW LIMITATIONS ON HOW LONG AN IMPLIED WARRANTY LASTS, SO THE ABOVE LIMITATION MAY NOT APPLY TO YOU.**

### What this Warranty Does not Cover

This warranty does not cover the following:

- any software programs, whether pre-loaded or shipped with the Machine, or installed subsequently;
- failure resulting from misuse (including but not limited to use of any Machine capacity or capability, other than that authorized by IBM in writing), accident, modification, unsuitable physical or operating environment, or improper maintenance by you;
- failure caused by a product for which IBM is not responsible; and
- any non-IBM products, including those that IBM may procure and provide with or integrate into an IBM Machine at your request.

The warranty is voided by removal or alteration of identification labels on the Machine or its parts.

IBM does not warrant uninterrupted or error-free operation of a Machine.

Any technical or other support provided for a Machine under warranty, such as assistance with “how-to” questions and those regarding Machine set-up and installation, is provided **WITHOUT WARRANTIES OF ANY KIND**.

### **How to Obtain Warranty Service**

If the Machine does not function as warranted during the warranty period, contact IBM or your reseller to obtain warranty service. If you do not register the Machine with IBM, you may be required to present proof of purchase as evidence of your entitlement to warranty service.

### **What IBM Will Do to Correct Problems**

When you contact IBM for service, you must follow the problem determination and resolution procedures that IBM specifies. An initial diagnosis of your problem can be made either by a technician over the telephone or electronically by access to an IBM website.

The type of warranty service applicable to your Machine is specified in Part 3 - Warranty Information.

You are responsible for downloading and installing designated Machine Code (microcode, basic input/output system code (called “BIOS”), utility programs, device drivers, and diagnostics delivered with an IBM Machine) and other software updates from an IBM Internet Web site or from other electronic media, and following the instructions that IBM provides.

If your problem can be resolved with a Customer Replaceable Unit (“CRU”) (e.g., keyboard, mouse, speaker, memory, hard disk drive), IBM will ship the CRU to you for you to install.

If the Machine does not function as warranted during the warranty period and your problem cannot be resolved over the telephone or electronically, through your application of Machine Code or software updates, or with a CRU, IBM or your reseller, if approved by IBM to provide warranty service, will either, at its discretion, 1) repair it to make it function as warranted, or 2) replace it with one that is at least functionally equivalent. If IBM is unable to do either, you may return the Machine to your place of purchase and your money will be refunded.

IBM or your reseller will also manage and install selected engineering changes that apply to the Machine.

### **Exchange of a Machine or Part**

When the warranty service involves the exchange of a Machine or part, the item IBM or your reseller replaces becomes its property and the replacement becomes yours. You represent that all removed items are genuine and unaltered. The replacement may not be new, but will be in good working order and at least functionally equivalent to the item replaced. The replacement assumes the warranty service status of the replaced item.

## **Your Additional Responsibilities**

Before IBM or your reseller exchanges a Machine or part, you agree to remove all features, parts, options, alterations, and attachments not under warranty service.

You also agree to:

1. ensure that the Machine is free of any legal obligations or restrictions that prevent its exchange;
2. obtain authorization from the owner to have IBM or your reseller service a Machine that you do not own; and
3. where applicable, before service is provided:
  - a. follow the service request procedures that IBM or your reseller provides;
  - b. backup or secure all programs, data, and funds contained in the Machine;
  - c. provide IBM or your reseller with sufficient, free, and safe access to your facilities to permit IBM to fulfill its obligations; and
  - d. inform IBM or your reseller of changes in the Machine's location.
4. (a) ensure all information about identified or identifiable individuals (Personal Data) is deleted from the Machine (to the extent technically possible), (b) allow IBM, your reseller or an IBM supplier to process on your behalf any remaining Personal Data as IBM or your reseller considers necessary to fulfill its obligations under this Statement of Limited Warranty (which may include shipping the Machine for such processing to other IBM service locations around the world), and (c) ensure that such processing complies with any laws applicable to such Personal Data.

## **Limitation of Liability**

IBM is responsible for loss of, or damage to, your Machine only while it is 1) in IBM's possession or 2) in transit in those cases where IBM is responsible for the transportation charges.

Neither IBM nor your reseller are responsible for any of your confidential, proprietary or personal information contained in a Machine which you return to IBM for any reason. You should remove all such information from the Machine prior to its return.

Circumstances may arise where, because of a default on IBM's part or other liability, you are entitled to recover damages from IBM. In each such instance, regardless of the basis on which you are entitled to claim damages from IBM (including fundamental breach, negligence, misrepresentation, or other contract or tort claim), except for any liability that cannot be waived or limited by applicable laws, IBM is liable for no more than

1. damages for bodily injury (including death) and damage to real property and tangible personal property; and
2. the amount of any other actual direct damages, up to the charges (if recurring, 12 months' charges apply) for the Machine that is subject of the claim. For purposes of this item, the term "Machine" includes Machine Code and Licensed Internal Code ("LIC").

This limit also applies to IBM's suppliers and your reseller. It is the maximum for which IBM, its suppliers, and your reseller are collectively responsible.

**UNDER NO CIRCUMSTANCES IS IBM, ITS SUPPLIERS OR RESELLERS LIABLE FOR ANY OF THE FOLLOWING EVEN IF INFORMED OF THEIR POSSIBILITY: 1) THIRD PARTY CLAIMS AGAINST YOU FOR DAMAGES (OTHER THAN THOSE UNDER THE FIRST ITEM LISTED ABOVE); 2) LOSS OF,**

OR DAMAGE TO, DATA; 3) SPECIAL, INCIDENTAL, OR INDIRECT DAMAGES OR FOR ANY ECONOMIC CONSEQUENTIAL DAMAGES; OR 4) LOST PROFITS, BUSINESS REVENUE, GOODWILL OR ANTICIPATED SAVINGS. SOME STATES OR JURISDICTIONS DO NOT ALLOW THE EXCLUSION OR LIMITATION OF INCIDENTAL OR CONSEQUENTIAL DAMAGES, SO THE ABOVE LIMITATION OR EXCLUSION MAY NOT APPLY TO YOU. SOME STATES OR JURISDICTIONS DO NOT ALLOW LIMITATIONS ON HOW LONG AN IMPLIED WARRANTY LASTS, SO THE ABOVE LIMITATION MAY NOT APPLY TO YOU.

### Governing Law

Both you and IBM consent to the application of the laws of the country in which you acquired the Machine to govern, interpret, and enforce all of your and IBM's rights, duties, and obligations arising from, or relating in any manner to, the subject matter of this Statement of Limited Warranty, without regard to conflict of law principles.

**THESE WARRANTIES GIVE YOU SPECIFIC LEGAL RIGHTS AND YOU MAY ALSO HAVE OTHER RIGHTS WHICH VARY FROM STATE TO STATE OR JURISDICTION TO JURISDICTION.**

### Jurisdiction

All of our rights, duties, and obligations are subject to the courts of the country in which you acquired the Machine.

---

## Part 2 - Country-unique Terms

### AMERICAS

#### **ARGENTINA**

**Jurisdiction:** *The following is added after the first sentence:*

Any litigation arising from this Statement of Limited Warranty will be settled exclusively by the Ordinary Commercial Court of the city of Buenos Aires.

#### **BOLIVIA**

**Jurisdiction:** *The following is added after the first sentence:*

Any litigation arising from this Statement of Limited Warranty will be settled exclusively by the courts of the city of La Paz.

#### **BRAZIL**

**Jurisdiction:** *The following is added after the first sentence:*

Any litigation arising from this Statement of Limited Warranty will be settled exclusively by the court of Rio de Janeiro, RJ.

#### **CHILE**

**Jurisdiction:** *The following is added after the first sentence:*

Any litigation arising from this Statement of Limited Warranty will be settled exclusively by the Civil Courts of Justice of Santiago.

## **COLOMBIA**

**Jurisdiction:** *The following is added after the first sentence:*

Any litigation arising from this Statement of Limited Warranty will be settled exclusively by the Judges of the Republic of Colombia.

## **EQUADOR**

**Jurisdiction:** *The following is added after the first sentence:*

Any litigation arising from this Statement of Limited Warranty will be settled exclusively by the Judges of Quito.

## **MEXICO**

**Jurisdiction:** *The following is added after the first sentence:*

Any litigation arising from this Statement of Limited Warranty will be settled exclusively by the Federal Courts of Mexico City, Federal District.

## **PARAGUAY**

**Jurisdiction:** *The following is added after the first sentence:*

Any litigation arising from this Statement of Limited Warranty will be settled exclusively by the courts of the city of Asuncion.

## **PERU**

**Limitation of Liability:** *The following is added at the end of this section:*

In accordance with Article 1328 of the Peruvian Civil Code the limitations and exclusions specified in this section will not apply to damages caused by IBM's willful misconduct ("dolo") or gross negligence ("culpa inexcusable").

## **URUGUAY**

**Jurisdiction:** *The following is added after the first sentence:*

Any litigation arising from this Statement of Limited Warranty will be settled exclusively by the City of Montevideo Court's Jurisdiction.

## **VENEZUELA**

**Jurisdiction:** *The following is added after the first sentence:*

Any litigation arising from this Statement of Limited Warranty will be settled exclusively by the Courts of the Metropolitan Area Of the City of Caracas.

## **NORTH AMERICA**

**How to Obtain Warranty Service:** *The following is added to this Section:*

To obtain warranty service from IBM in Canada or the United States, call 1-800-IBM-SERV (426-7378).

## CANADA

**Limitation of Liability:** *The following replaces item 1 of this section:*

1. damages for bodily injury (including death) or physical harm to real property and tangible personal property caused by IBM's negligence; and

**Governing Law:** *The following replaces "laws of the country in which you acquired the Machine" in the first sentence:*

laws in the Province of Ontario.

## UNITED STATES

**Governing Law:** *The following replaces "laws of the country in which you acquired the Machine" in the first sentence:*

laws of the State of New York.

## ASIA PACIFIC

### AUSTRALIA

**What this Warranty Covers:** *The following paragraph is added to this section:*

The warranties specified in this Section are in addition to any rights you may have under the Trade Practices Act 1974 or other similar legislation and are only limited to the extent permitted by the applicable legislation.

**Limitation of Liability:** *The following is added to this section:*

Where IBM is in breach of a condition or warranty implied by the Trade Practices Act 1974 or other similar legislation, IBM's liability is limited to the repair or replacement of the goods or the supply of equivalent goods. Where that condition or warranty relates to right to sell, quiet possession or clear title, or the goods are of a kind ordinarily acquired for personal, domestic or household use or consumption, then none of the limitations in this paragraph apply.

**Governing Law:** *The following replaces "laws of the country in which you acquired the Machine" in the first sentence:*

laws of the State or Territory.

### CAMBODIA AND LAOS

**Governing Law:** *The following replaces "laws of the country in which you acquired the Machine" in the first sentence:*

laws of the State of New York, United States of America.

### CAMBODIA, INDONESIA, AND LAOS

**Arbitration:** *The following is added under this heading:*

Disputes arising out of or in connection with this Statement of Limited Warranty shall be finally settled by arbitration which shall be held in Singapore in accordance with the Arbitration Rules of Singapore International Arbitration Center ("SIAC Rules") then in effect. The arbitration award shall be final and binding for the parties without appeal and shall be in writing and set forth the findings of fact and the conclusions of law.

The number of arbitrators shall be three, with each side to the dispute being entitled to appoint one arbitrator. The two arbitrators appointed by the parties shall appoint a third arbitrator who shall act as chairman of the proceedings. Vacancies in the



post of chairman shall be filled by the president of the SIAC. Other vacancies shall be filled by the respective nominating party. Proceedings shall continue from the stage they were at when the vacancy occurred.

If one of the parties refuses or otherwise fails to appoint an arbitrator within 30 days of the date the other party appoints its, the first appointed arbitrator shall be the sole arbitrator, provided that the arbitrator was validly and properly appointed.

All proceedings shall be conducted, including all documents presented in such proceedings, in the English language. The English language version of this Statement of Limited Warranty prevails over any other language version.

## **HONG KONG S.A.R. OF CHINA AND MACAU S.A.R. OF CHINA**

**Governing Law:** *The following replaces “laws of the country in which you acquired the Machine” in the first sentence:*  
laws of Hong Kong Special Administrative Region of China.

## **INDIA**

**Limitation of Liability:** *The following replaces items 1 and 2 of this section:*

1. liability for bodily injury (including death) or damage to real property and tangible personal property will be limited to that caused by IBM's negligence; and
2. as to any other actual damage arising in any situation involving nonperformance by IBM pursuant to, or in any way related to the subject of this Statement of Limited Warranty, the charge paid by you for the individual Machine that is the subject of the claim. For purposes of this item, the term “Machine” includes Machine Code and Licensed Internal Code (“LIC”).

**Arbitration:** *The following is added under this heading:*

Disputes arising out of or in connection with this Statement of Limited Warranty shall be finally settled by arbitration which shall be held in Bangalore, India in accordance with the laws of India then in effect. The arbitration award shall be final and binding for the parties without appeal and shall be in writing and set forth the findings of fact and the conclusions of law.

The number of arbitrators shall be three, with each side to the dispute being entitled to appoint one arbitrator. The two arbitrators appointed by the parties shall appoint a third arbitrator who shall act as chairman of the proceedings. Vacancies in the post of chairman shall be filled by the president of the Bar Council of India. Other vacancies shall be filled by the respective nominating party. Proceedings shall continue from the stage they were at when the vacancy occurred.

If one of the parties refuses or otherwise fails to appoint an arbitrator within 30 days of the date the other party appoints its, the first appointed arbitrator shall be the sole arbitrator, provided that the arbitrator was validly and properly appointed.

All proceedings shall be conducted, including all documents presented in such proceedings, in the English language. The English language version of this Statement of Limited Warranty prevails over any other language version.

## **JAPAN**

**Governing Law:** *The following sentence is added to this section:*

Any doubts concerning this Statement of Limited Warranty will be initially resolved between us in good faith and in accordance with the principle of mutual trust.

## **MALAYSIA**

**Limitation of Liability:** *The word “SPECIAL” in item 3 of the fifth paragraph is deleted.*

## **NEW ZEALAND**

**What this Warranty Covers:** *The following paragraph is added to this section:*

The warranties specified in this section are in addition to any rights you may have under the Consumer Guarantees Act 1993 or other legislation which cannot be excluded or limited. The Consumer Guarantees Act 1993 will not apply in respect of any goods which IBM provides, if you require the goods for the purposes of a business as defined in that Act.

**Limitation of Liability:** *The following is added to this section:*

Where Machines are not acquired for the purposes of a business as defined in the Consumer Guarantees Act 1993, the limitations in this section are subject to the limitations in that Act.

## **PEOPLE’S REPUBLIC OF CHINA (PRC)**

**Governing Law:** *The following replaces “laws of the country in which you acquired the Machine” in the first sentence:*

laws of the State of New York, United States of America (except when local law requires otherwise).

## **PHILIPPINES**

**Limitation of Liability:** *Item 3 in the fifth paragraph is replaced by the following:*

**SPECIAL (INCLUDING NOMINAL AND EXEMPLARY DAMAGES), MORAL, INCIDENTAL, OR INDIRECT DAMAGES FOR ANY ECONOMIC CONSEQUENTIAL DAMAGES; OR**

**Arbitration:** *The following is added under this heading:*

Disputes arising out of or in connection with this Statement of Limited Warranty shall be finally settled by arbitration which shall be held in Metro Manila, Philippines in accordance with the laws of the Philippines then in effect. The arbitration award shall be final and binding for the parties without appeal and shall be in writing and set forth the findings of fact and the conclusions of law.

The number of arbitrators shall be three, with each side to the dispute being entitled to appoint one arbitrator. The two arbitrators appointed by the parties shall appoint a third arbitrator who shall act as chairman of the proceedings. Vacancies in the post of chairman shall be filled by the president of the Philippine Dispute Resolution Center, Inc. Other vacancies shall be filled by the respective nominating party. Proceedings shall continue from the stage they were at when the vacancy occurred.

If one of the parties refuses or otherwise fails to appoint an arbitrator within 30 days of the date the other party appoints its, the first appointed arbitrator shall be the sole arbitrator, provided that the arbitrator was validly and properly appointed.

All proceedings shall be conducted, including all documents presented in such proceedings, in the English language. The English language version of this Statement of Limited Warranty prevails over any other language version.

## **SINGAPORE**

**Limitation of Liability:** *The words “SPECIAL” and “ECONOMIC” in item 3 in the fifth paragraph are deleted.*

## **EUROPE, MIDDLE EAST, AFRICA (EMEA)**

### ***THE FOLLOWING TERMS APPLY TO ALL EMEA COUNTRIES:***

The terms of this Statement of Limited Warranty apply to Machines purchased from IBM or an IBM reseller.

### **How to Obtain Warranty Service:**

*Add the following paragraph in **Western Europe** (Andorra, Austria, Belgium, Cyprus, Czech Republic, Denmark, Estonia, Finland, France, Germany, Greece, Hungary, Iceland, Ireland, Italy, Latvia, Liechtenstein, Lithuania, Luxembourg, Malta, Monaco, Netherlands, Norway, Poland, Portugal, San Marino, Slovakia, Slovenia, Spain, Sweden, Switzerland, United Kingdom, Vatican State, and any country subsequently added to the European Union, as from the date of accession):*

The warranty for Machines acquired in Western Europe shall be valid and applicable in all Western Europe countries provided the Machines have been announced and made available in such countries.

If you purchase a Machine in one of the Western European countries, as defined above, you may obtain warranty service for that Machine in any of those countries from either (1) an IBM reseller approved to perform warranty service or (2) from IBM, provided the Machine has been announced and made available by IBM in the country in which you wish to obtain service.

If you purchased a Personal Computer Machine in Albania, Armenia, Belarus, Bosnia and Herzegovina, Bulgaria, Croatia, Czech Republic, Georgia, Hungary, Kazakhstan, Kyrgyzstan, Federal Republic of Yugoslavia, Former Yugoslav Republic of Macedonia (FYROM), Moldova, Poland, Romania, Russia, Slovak Republic, Slovenia, or Ukraine, you may obtain warranty service for that Machine in any of those countries from either (1) an IBM reseller approved to perform warranty service or (2) from IBM.

If you purchase a Machine in a Middle Eastern or African country, you may obtain warranty service for that Machine from the IBM entity within the country of purchase, if that IBM entity provides warranty service in that country, or from an IBM reseller, approved by IBM to perform warranty service on that Machine in that country. Warranty service in Africa is available within 50 kilometers of an IBM approved service provider. You are responsible for transportation costs for Machines located outside 50 kilometers of an IBM approved service provider.

### **Governing Law:**

*The phrase “the laws of the country in which you acquired the Machine” is replaced by:*

1) “the laws of Austria” in **Albania, Armenia, Azerbaijan, Belarus, Bosnia-Herzegovina, Bulgaria, Croatia, Georgia, Hungary, Kazakhstan, Kyrgyzstan, FYR Macedonia, Moldova, Poland, Romania, Russia, Slovakia, Slovenia, Tajikistan, Turkmenistan, Ukraine, Uzbekistan, and FR Yugoslavia**; 2) “the laws of France” in **Algeria, Benin, Burkina Faso, Cameroon, Cape Verde, Central African Republic, Chad, Comoros, Congo Republic, Djibouti, Democratic Republic of Congo, Equatorial Guinea, French Guiana, French Polynesia, Gabon, Gambia, Guinea, Guinea-Bissau, Ivory Coast, Lebanon, Madagascar, Mali, Mauritania, Mauritius, Mayotte, Morocco, New Caledonia, Niger, Reunion, Senegal, Seychelles, Togo, Tunisia, Vanuatu, and Wallis & Futuna**; 3) “the laws of Finland” in **Estonia, Latvia, and Lithuania**; 4) “the laws of England” in **Angola, Bahrain, Botswana, Burundi, Egypt, Eritrea, Ethiopia, Ghana, Jordan, Kenya, Kuwait, Liberia, Malawi, Malta, Mozambique, Nigeria, Oman, Pakistan, Qatar, Rwanda, Sao Tome, Saudi Arabia, Sierra Leone, Somalia, Tanzania, Uganda, United Arab Emirates, the United Kingdom, West Bank/Gaza, Yemen, Zambia, and Zimbabwe**; and 5) “the laws of South Africa” in **South Africa, Namibia, Lesotho and Swaziland**.

**Jurisdiction:** *The following exceptions are added to this section:*

1) **In Austria** the choice of jurisdiction for all disputes arising out of this Statement of Limited Warranty and relating thereto, including its existence, will be the competent court of law in Vienna, Austria (Inner-City); 2) **in Angola, Bahrain, Botswana, Burundi, Egypt, Eritrea, Ethiopia, Ghana, Jordan, Kenya, Kuwait, Liberia, Malawi, Malta, Mozambique, Nigeria, Oman, Pakistan, Qatar, Rwanda, Sao Tome, Saudi Arabia, Sierra Leone, Somalia, Tanzania, Uganda, United Arab Emirates, West Bank/Gaza, Yemen, Zambia, and Zimbabwe** all disputes arising out of this Statement of Limited Warranty or related to its execution, including summary proceedings, will be submitted to the exclusive jurisdiction of the English courts; 3) **in Belgium and Luxembourg**, all disputes arising out of this Statement of Limited Warranty or related to its interpretation or its execution, the law, and the courts of the capital city, of the country of your registered office and/or commercial site location only are competent; 4) **in France, Algeria, Benin, Burkina Faso, Cameroon, Cape Verde, Central African Republic, Chad, Comoros, Congo Republic, Djibouti, Democratic Republic of Congo, Equatorial Guinea, French Guiana, French Polynesia, Gabon, Gambia, Guinea, Guinea-Bissau, Ivory Coast, Lebanon, Madagascar, Mali, Mauritania, Mauritius, Mayotte, Morocco, New Caledonia, Niger, Reunion, Senegal, Seychelles, Togo, Tunisia, Vanuatu, and Wallis & Futuna** all disputes arising out of this Statement of Limited Warranty or related to its violation or execution, including summary proceedings, will be settled exclusively by the Commercial Court of Paris; 5) **in Russia**, all disputes arising out of or in relation to the interpretation, the violation, the termination, the nullity of the execution of this Statement of Limited Warranty shall be settled by Arbitration Court of Moscow; 6) **in South Africa, Namibia, Lesotho and Swaziland**, both of us agree to submit all disputes relating to this Statement of Limited Warranty to the jurisdiction of the High Court in Johannesburg; 7) **in Turkey** all disputes arising out of or in connection with this Statement of Limited Warranty shall be resolved by the Istanbul Central (Sultanahmet) Courts and Execution Directorates of Istanbul, the Republic of Turkey; 8) in each of the following specified countries, any legal claim arising out of this Statement of Limited Warranty will be brought before, and settled exclusively by, the competent court of a) Athens for **Greece**, b) Tel Aviv-Jaffa for **Israel**, c) Milan for **Italy**, d) Lisbon for **Portugal**, and e)

Madrid for **Spain**; and 9) **in the United Kingdom**, both of us agree to submit all disputes relating to this Statement of Limited Warranty to the jurisdiction of the English courts.

**Arbitration:** *The following is added under this heading:*

**In Albania, Armenia, Azerbaijan, Belarus, Bosnia-Herzegovina, Bulgaria, Croatia, Georgia, Hungary, Kazakhstan, Kyrgyzstan, FYR Macedonia, Moldova, Poland, Romania, Russia, Slovakia, Slovenia, Tajikistan, Turkmenistan, Ukraine, Uzbekistan, and FR Yugoslavia** all disputes arising out of this Statement of Limited Warranty or related to its violation, termination or nullity will be finally settled under the Rules of Arbitration and Conciliation of the International Arbitral Center of the Federal Economic Chamber in Vienna (Vienna Rules) by three arbitrators appointed in accordance with these rules. The arbitration will be held in Vienna, Austria, and the official language of the proceedings will be English. The decision of the arbitrators will be final and binding upon both parties. Therefore, pursuant to paragraph 598 (2) of the Austrian Code of Civil Procedure, the parties expressly waive the application of paragraph 595 (1) figure 7 of the Code. IBM may, however, institute proceedings in a competent court in the country of installation.

**In Estonia, Latvia and Lithuania** all disputes arising in connection with this Statement of Limited Warranty will be finally settled in arbitration that will be held in Helsinki, Finland in accordance with the arbitration laws of Finland then in effect. Each party will appoint one arbitrator. The arbitrators will then jointly appoint the chairman. If arbitrators cannot agree on the chairman, then the Central Chamber of Commerce in Helsinki will appoint the chairman.

## **EUROPEAN UNION (EU)**

### ***THE FOLLOWING TERMS APPLY TO ALL EU COUNTRIES:***

The warranty for Machines acquired in EU countries is valid and applicable in all EU countries provided the Machines have been announced and made available in such countries.

**How to Obtain Warranty Service:** *The following is added to this section:*

To obtain warranty service from IBM in EU countries, see the telephone listing in Part 3 - Warranty Information.

You may contact IBM at the following address:

IBM Warranty & Service Quality Dept.  
PO Box 30  
Spango Valley  
Greenock  
Scotland PA16 0AH

## **CONSUMERS**

Consumers have legal rights under applicable national legislation governing the sale of consumer goods. Such rights are not affected by the warranties provided in this Statement of Limited Warranty.

**AUSTRIA, DENMARK, FINLAND, GREECE, ITALY, NETHERLANDS, NORWAY, PORTUGAL, SPAIN, SWEDEN AND SWITZERLAND**

**Limitation of Liability:** *The following replaces the terms of this section in its entirety:*

Except as otherwise provided by mandatory law:

1. IBM's liability for any damages and losses that may arise as a consequence of the fulfillment of its obligations under or in connection with this Statement of Limited Warranty or due to any other cause related to this Statement of Limited Warranty is limited to the compensation of only those damages and losses proved and actually arising as an immediate and direct consequence of the non-fulfillment of such obligations (if IBM is at fault) or of such cause, for a maximum amount equal to the charges you paid for the Machine. For purposes of this item, the term "Machine" includes Machine Code and Licensed Internal Code ("LIC").

The above limitation shall not apply to damages for bodily injuries (including death) and damages to real property and tangible personal property for which IBM is legally liable.

2. **UNDER NO CIRCUMSTANCES IS IBM, ITS SUPPLIERS OR RESELLERS LIABLE FOR ANY OF THE FOLLOWING, EVEN IF INFORMED OF THEIR POSSIBILITY: 1) LOSS OF, OR DAMAGE TO, DATA; 2) INCIDENTAL OR INDIRECT DAMAGES, OR FOR ANY ECONOMIC CONSEQUENTIAL DAMAGES; 3) LOST PROFITS, EVEN IF THEY ARISE AS AN IMMEDIATE CONSEQUENCE OF THE EVENT THAT GENERATED THE DAMAGES; OR 4) LOSS OF BUSINESS, REVENUE, GOODWILL, OR ANTICIPATED SAVINGS.**

## **FRANCE AND BELGIUM**

**Limitation of Liability:** *The following replaces the terms of this section in its entirety:*

Except as otherwise provided by mandatory law:

1. IBM's liability for any damages and losses that may arise as a consequence of the fulfillment of its obligations under or in connection with this Statement of Limited Warranty is limited to the compensation of only those damages and losses proved and actually arising as an immediate and direct consequence of the non-fulfillment of such obligations (if IBM is at fault), for a maximum amount equal to the charges you paid for the Machine that has caused the damages. For purposes of this item, the term "Machine" includes Machine Code and Licensed Internal Code ("LIC").

The above limitation shall not apply to damages for bodily injuries (including death) and damages to real property and tangible personal property for which IBM is legally liable.

2. **UNDER NO CIRCUMSTANCES IS IBM, ITS SUPPLIERS OR RESELLERS LIABLE FOR ANY OF THE FOLLOWING, EVEN IF INFORMED OF THEIR POSSIBILITY: 1) LOSS OF, OR DAMAGE TO, DATA; 2) INCIDENTAL OR INDIRECT DAMAGES, OR FOR ANY ECONOMIC CONSEQUENTIAL DAMAGES; 3) LOST PROFITS, EVEN IF THEY ARISE AS AN IMMEDIATE CONSEQUENCE OF THE EVENT THAT GENERATED THE DAMAGES; OR 4) LOSS OF BUSINESS, REVENUE, GOODWILL, OR ANTICIPATED SAVINGS.**

**THE FOLLOWING TERMS APPLY TO THE COUNTRY SPECIFIED:**

## **AUSTRIA**

**The provisions of this Statement of Limited Warranty replace any applicable statutory warranties.**

**What this Warranty Covers:** *The following replaces the first sentence of the first paragraph of this section:*

The warranty for an IBM Machine covers the functionality of the Machine for its normal use and the Machine's conformity to its Specifications.

*The following paragraphs are added to this section:*

The limitation period for consumers in action for breach of warranty is the statutory period as a minimum. In case IBM or your reseller is unable to repair an IBM Machine, you can alternatively ask for a partial refund as far as justified by the reduced value of the unrepaired Machine or ask for a cancellation of the respective agreement for such Machine and get your money refunded.

*The second paragraph does not apply.*

**What IBM Will Do to Correct Problems:** *The following is added to this section:*

During the warranty period, IBM will reimburse you for the transportation charges for the delivery of the failing Machine to IBM.

**Limitation of Liability:** *The following paragraph is added to this section:*

The limitations and exclusions specified in the Statement of Limited Warranty will not apply to damages caused by IBM with fraud or gross negligence and for express warranty.

*The following sentence is added to the end of item 2:*

IBM's liability under this item is limited to the violation of essential contractual terms in cases of ordinary negligence.

## **EGYPT**

**Limitation of Liability:** *The following replaces item 2 in this section:*

as to any other actual direct damages, IBM's liability will be limited to the total amount you paid for the Machine that is the subject of the claim. For purposes of this item, the term "Machine" includes Machine Code and Licensed Internal Code ("LIC").

*Applicability of suppliers and resellers (unchanged).*

## **FRANCE**

**Limitation of Liability:** *The following replaces the second sentence of the first paragraph of this section:*

In such instances, regardless of the basis on which you are entitled to claim damages from IBM, IBM is liable for no more than: (items 1 and 2 unchanged).

## **GERMANY**

**What this Warranty Covers:** *The following replaces the first sentence of the first paragraph of this section:*

The warranty for an IBM Machine covers the functionality of the Machine for its normal use and the Machine's conformity to its Specifications.

*The following paragraphs are added to this section:*

The minimum warranty period for Machines is twelve months. In case IBM or your reseller is unable to repair an IBM Machine, you can alternatively ask for a partial refund as far as justified by the reduced value of the unrepaired Machine or ask for a cancellation of the respective agreement for such Machine and get your money refunded.

*The second paragraph does not apply.*

**What IBM Will Do to Correct Problems:** *The following is added to this section:*

During the warranty period, transportation for delivery of the failing Machine to IBM will be at IBM's expense.

**Limitation of Liability:** *The following paragraph is added to this section:*

The limitations and exclusions specified in the Statement of Limited Warranty will not apply to damages caused by IBM with fraud or gross negligence and for express warranty.

*The following sentence is added to the end of item 2:*

IBM's liability under this item is limited to the violation of essential contractual terms in cases of ordinary negligence.

## **HUNGARY**

**Limitation of Liability:** *The following is added at the end of this section:*

The limitation and exclusion specified herein shall not apply to liability for a breach of contract damaging life, physical well-being, or health that has been caused intentionally, by gross negligence, or by a criminal act.

The parties accept the limitations of liability as valid provisions and state that the Section 314.(2) of the Hungarian Civil Code applies as the acquisition price as well as other advantages arising out of the present Statement of Limited Warranty balance this limitation of liability.

## **IRELAND**

**What this Warranty Covers:** *The following is added to this section:*

Except as expressly provided in these terms and conditions, all statutory conditions, including all warranties implied, but without prejudice to the generality of the foregoing all warranties implied by the Sale of Goods Act 1893 or the Sale of Goods and Supply of Services Act 1980 are hereby excluded.

**Limitation of Liability:** *The following replaces the terms of this section in its entirety:*

For the purposes of this section, a "Default" means any act, statement, omission, or negligence on the part of IBM in connection with, or in relation to, the subject matter of this Statement of Limited Warranty in respect of which IBM is legally liable to



you, whether in contract or tort. A number of Defaults which together result in, or contribute to, substantially the same loss or damage will be treated as one Default occurring on the date of occurrence of the last such Default.

Circumstances may arise where, because of a Default, you are entitled to recover damages from IBM.

This section sets out the extent of IBM's liability and your sole remedy.

1. IBM will accept unlimited liability for death or personal injury caused by the negligence of IBM.
2. Subject always to the **Items for Which IBM is Not Liable** below, IBM will accept unlimited liability for physical damage to your tangible property resulting from the negligence of IBM.
3. Except as provided in items 1 and 2 above, IBM's entire liability for actual damages for any one Default will not in any event exceed the greater of 1) EUR 125,000, or 2) 125% of the amount you paid for the Machine directly relating to the Default.

#### **Items for Which IBM is Not Liable**

Save with respect to any liability referred to in item 1 above, under no circumstances is IBM, its suppliers or resellers liable for any of the following, even if IBM or they were informed of the possibility of such losses:

1. loss of, or damage to, data;
2. special, indirect, or consequential loss; or
3. loss of profits, business, revenue, goodwill, or anticipated savings.

#### **SLOVAKIA**

**Limitation of Liability:** *The following is added to the end of the last paragraph:*

The limitations apply to the extent they are not prohibited under §§ 373-386 of the Slovak Commercial Code.

#### **SOUTH AFRICA, NAMIBIA, BOTSWANA, LESOTHO AND SWAZILAND**

**Limitation of Liability:** *The following is added to this section:*

IBM's entire liability to you for actual damages arising in all situations involving nonperformance by IBM in respect of the subject matter of this Statement of Warranty will be limited to the charge paid by you for the individual Machine that is the subject of your claim from IBM.

#### **UNITED KINGDOM**

**Limitation of Liability:** *The following replaces the terms of this section in its entirety:*

For the purposes of this section, a "Default" means any act, statement, omission, or negligence on the part of IBM in connection with, or in relation to, the subject matter of this Statement of Limited Warranty in respect of which IBM is legally liable to you, whether in contract or tort. A number of Defaults which together result in, or contribute to, substantially the same loss or damage will be treated as one Default.

Circumstances may arise where, because of a Default, you are entitled to recover damages from IBM.

This section sets out the extent of IBM's liability and your sole remedy.

1. IBM will accept unlimited liability for:
  - a. death or personal injury caused by the negligence of IBM; and
  - b. any breach of its obligations implied by Section 12 of the Sale of Goods Act 1979 or Section 2 of the Supply of Goods and Services Act 1982, or any statutory modification or re-enactment of either such Section.
2. IBM will accept unlimited liability, subject always to the **Items for Which IBM is Not Liable** below, for physical damage to your tangible property resulting from the negligence of IBM.
3. IBM's entire liability for actual damages for any one Default will not in any event, except as provided in items 1 and 2 above, exceed the greater of 1) Pounds Sterling 75,000, or 2) 125% of the total purchase price payable or the charges for the Machine directly relating to the Default.

These limits also apply to IBM's suppliers and resellers. They state the maximum for which IBM and such suppliers and resellers are collectively responsible.

#### **Items for Which IBM is Not Liable**

Save with respect to any liability referred to in item 1 above, under no circumstances is IBM or any of its suppliers or resellers liable for any of the following, even if IBM or they were informed of the possibility of such losses:

1. loss of, or damage to, data;
2. special, indirect, or consequential loss; or
3. loss of profits, business, revenue, goodwill, or anticipated savings.

---

## **Part 3 - Warranty Information**

This Part 3 provides information regarding the warranty applicable to your Machine, including the warranty period and type of warranty service IBM provides.

### **Warranty Period**

The warranty period may vary by country or region and is specified in the table below.

**Note:** "Region" means either Hong Kong or Macau Special Administrative Region of China.

A warranty period of 3 years on parts and 1 year on labor means that IBM provides warranty service without charge for:

1. parts and labor during the first year of the warranty period; and
2. parts only, on an exchange basis, in the second and third years of the warranty period. IBM will charge you for any labor provided in performance of the repair or replacement(s) in the second and third year of the warranty period.

### **IBM DPI C13 PDU+, IBM DPI C13 3-phase PDU+, IBM DPI C19 PDU+, and IBM DPI C19 3-phase PDU+**

<b>Country or Region of Purchase</b>	<b>Warranty Period</b>	<b>Type of Warranty Service*</b>
Worldwide	1 year	1
* See " <u>Types of Warranty Service</u> " for the legend and explanations of warranty-service types.		

## **Types of Warranty Service**

If required, IBM provides repair or exchange service depending on the type of warranty service specified for your Machine in the above table and as described below. Warranty service may be provided by your reseller if approved by IBM to perform warranty service. Scheduling of service will depend upon the time of your call and is subject to parts availability. Service levels are response time objectives and are not guaranteed. The specified level of warranty service may not be available in all worldwide locations, additional charges may apply outside IBM's normal service area, contact your local IBM representative or your reseller for country and location specific information.

### **1. Customer Replaceable Unit (“CRU”) Service**

IBM provides replacement CRUs to you for you to install. CRU information and replacement instructions are shipped with your Machine and are available from IBM at any time on your request. Installation of Tier 1 CRUs is your responsibility. If IBM installs a Tier 1 CRU at your request, you will be charged for the installation. You may install a Tier 2 CRU yourself or request IBM to install it, at no additional charge, under the type of warranty service designated for your Machine. IBM specifies in the materials shipped with a replacement CRU whether a defective CRU must be returned to IBM. When return is required, 1) return instructions and a container are shipped with the replacement CRU, and 2) you may be charged for the replacement CRU if IBM does not receive the defective CRU within 30 days of your receipt of the replacement.

### **2. On-site Service**

IBM or your reseller will either repair or exchange the failing Machine at your location and verify its operation. You must provide suitable working area to allow disassembly and reassembly of the IBM Machine. The area must be clean, well lit and suitable for the purpose. For some Machines, certain repairs may require sending the Machine to an IBM service center.

### **3. Courier or Depot Service\***

You will disconnect the failing Machine for collection arranged by IBM. IBM will provide you with a shipping container for you to return your Machine to a designated service center. A courier will pick up your Machine and deliver it to the designated service center. Following its repair or exchange, IBM will arrange the return delivery of the Machine to your location. You are responsible for its installation and verification.

### **4. Customer Carry-In or Mail-In Service**

You will deliver or mail as IBM specifies (prepaid unless IBM specifies otherwise) the failing Machine suitably packaged to a location IBM designates. After IBM has repaired or exchanged the Machine, IBM will make it available for your collection or, for Mail-in Service, IBM will return it to you at IBM's expense, unless IBM specifies otherwise. You are responsible for the subsequent installation and verification of the Machine.

### **5. CRU and On-site Service**

This type of Warranty Service is a combination of Type 1 and Type 2 (see above).

### **6. CRU and Courier or Depot Service**

This type of Warranty Service is a combination of Type 1 and Type 3 (see above).

### **7. CRU and Customer Carry-In or Mail-In Service**

This type of Warranty Service is a combination of Type 1 and Type 4 (see above).

**When a 5, 6 or 7 type of warranty service is listed, IBM will determine which type of warranty service is appropriate for the repair.**

\* This type of service is called ThinkPad EasyServ or EasyServ in some countries.

The IBM Machine Warranty World Wide Web site at [http://www.ibm.com/servers/support/machine\\_warranties/](http://www.ibm.com/servers/support/machine_warranties/) provides a worldwide overview of IBM's Limited Warranty for Machines, a Glossary of IBM definitions, Frequently Asked Questions (FAQs) and Support by Product (Machine) with links to Product Support pages. **The IBM Statement of Limited Warranty is also available on this site in 29 languages.**

To obtain warranty service contact IBM or your IBM reseller. In Canada or the United States, call 1-800-IBM-SERV (426-7378). In the EU countries, see the telephone numbers below.

### **EU Country Telephone List**

Phone numbers are subject to change without notice. For the warranty service contact telephone number in a country subsequently added to the EU and not yet reflected in the list below, contact IBM in that country or visit the website above for a current telephone listing.

Austria -- +43-1-24592-5901	Latvia -- +386-61-1796-699
Belgium -- +32-70-23-3392	Lithuania -- +386-61-1796-699
Cyprus -- +357-22-841100	Luxembourg -- +352-298-977-5063
Czech Republic -- +420-2-7213-1316	Malta -- +356-23-4175
Denmark -- +45-4520-8200	Netherlands -- +31-20-514-5770
Estonia -- +386-61-1796-699	Poland -- +48-22-878-6999
Finland -- +358-8001-4260	Portugal -- +351-21-892-7147
France -- +33-238-557-450	Slovakia -- +421-2-4954-1217
Germany -- +49-1805-253553	Slovenia -- +386-1-4796-699
Greece -- +30-210-680-1700	Spain -- +34-91-714-7983
Hungary -- +36-1-382-5720	Sweden -- +46-8-477-4420
Ireland -- +353-1-815-4000	United Kingdom -- +44-0870-550-0900
Italy -- +39-800-820-094	

---

## Appendix C. Notices

This information was developed for products and services offered in the U.S.A.

IBM may not offer the products, services, or features discussed in this document in other countries. Consult your local IBM representative for information on the products and services currently available in your area. Any reference to an IBM product, program, or service is not intended to state or imply that only that IBM product, program, or service may be used. Any functionally equivalent product, program, or service that does not infringe any IBM intellectual property right may be used instead. However, it is the user's responsibility to evaluate and verify the operation of any non-IBM product, program, or service.

IBM may have patents or pending patent applications covering subject matter described in this document. The furnishing of this document does not give you any license to these patents. You can send license inquiries, in writing, to:

*IBM Director of Licensing  
IBM Corporation  
North Castle Drive  
Armonk, NY 10504-1785  
U.S.A.*

INTERNATIONAL BUSINESS MACHINES CORPORATION PROVIDES THIS PUBLICATION "AS IS" WITHOUT WARRANTY OF ANY KIND, EITHER EXPRESS OR IMPLIED, INCLUDING, BUT NOT LIMITED TO, THE IMPLIED WARRANTIES OF NON-INFRINGEMENT, MERCHANTABILITY OR FITNESS FOR A PARTICULAR PURPOSE. Some states do not allow disclaimer of express or implied warranties in certain transactions, therefore, this statement may not apply to you.

This information could include technical inaccuracies or typographical errors. Changes are periodically made to the information herein; these changes will be incorporated in new editions of the publication. IBM may make improvements and/or changes in the product(s) and/or the program(s) described in this publication at any time without notice.

Any references in this information to non-IBM Web sites are provided for convenience only and do not in any manner serve as an endorsement of those Web sites. The materials at those Web sites are not part of the materials for this IBM product, and use of those Web sites is at your own risk.

IBM may use or distribute any of the information you supply in any way it believes appropriate without incurring any obligation to you.

---

## Trademarks

The following terms are trademarks of International Business Machines Corporation in the United States, other countries, or both:

IBM	FlashCopy	TechConnect
IBM (logo)	i5/OS	Tivoli
Active Memory	IntelliStation	Tivoli Enterprise
Active PCI	NetBAY	Update Connector
Active PCI-X	Netfinity	Wake on LAN

AIX	PowerExecutive	XA-32
Alert on LAN	Predictive Failure Analysis	XA-64
BladeCenter	ServeRAID	X-Architecture
Chipkill	ServerGuide	XpandOnDemand
e-business logo	ServerProven	xSeries
@server	System x	

Intel, Intel Xeon, Itanium, and Pentium are trademarks of Intel Corporation in the United States, other countries, or both.

Microsoft, Windows, and Windows NT are trademarks of Microsoft Corporation in the United States, other countries, or both.

Adobe and PostScript are either registered trademarks or trademarks of Adobe Systems Incorporated in the United States, other countries, or both.

UNIX is a registered trademark of The Open Group in the United States and other countries.

Java and all Java-based trademarks are trademarks of Sun Microsystems, Inc. in the United States, other countries, or both.

Adaptec and HostRAID are trademarks of Adaptec, Inc., in the United States, other countries, or both.

Linux is a registered trademark of Linus Torvalds in the United States, other countries, or both.

Red Hat, the Red Hat “Shadow Man” logo, and all Red Hat-based trademarks and logos are trademarks or registered trademarks of Red Hat, Inc., in the United States and other countries.

Other company, product, or service names may be trademarks or service marks of others.

---

## Important notes

Processor speed indicates the internal clock speed of the microprocessor; other factors also affect application performance.

CD or DVD drive speed is the variable read rate. Actual speeds vary and are often less than the possible maximum.

When referring to processor storage, real and virtual storage, or channel volume, KB stands for 1024 bytes, MB stands for 1 048 576 bytes, and GB stands for 1 073 741 824 bytes.

When referring to hard disk drive capacity or communications volume, MB stands for 1 000 000 bytes, and GB stands for 1 000 000 000 bytes. Total user-accessible capacity can vary depending on operating environments.

Maximum internal hard disk drive capacities assume the replacement of any standard hard disk drives and population of all hard disk drive bays with the largest currently supported drives that are available from IBM.

Maximum memory might require replacement of the standard memory with an optional memory module.

IBM makes no representation or warranties regarding non-IBM products and services that are ServerProven<sup>®</sup>, including but not limited to the implied warranties of merchantability and fitness for a particular purpose. These products are offered and warranted solely by third parties.

IBM makes no representations or warranties with respect to non-IBM products. Support (if any) for the non-IBM products is provided by the third party, not IBM.

Some software might differ from its retail version (if available) and might not include user manuals or all program functionality.

---

## Product recycling and disposal

This unit must be recycled or discarded according to applicable local and national regulations. IBM encourages owners of information technology (IT) equipment to responsibly recycle their equipment when it is no longer needed. IBM offers a variety of product return programs and services in several countries to assist equipment owners in recycling their IT products. Information on IBM product recycling offerings can be found on IBM's Internet site at <http://www.ibm.com/ibm/environment/products/index.shtml>.

Esta unidad debe reciclarse o desecharse de acuerdo con lo establecido en la normativa nacional o local aplicable. IBM recomienda a los propietarios de equipos de tecnología de la información (TI) que reciclen responsablemente sus equipos cuando éstos ya no les sean útiles. IBM dispone de una serie de programas y servicios de devolución de productos en varios países, a fin de ayudar a los propietarios de equipos a reciclar sus productos de TI. Se puede encontrar información sobre las ofertas de reciclado de productos de IBM en el sitio web de IBM <http://www.ibm.com/ibm/environment/products/index.shtml>.

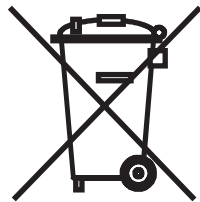

**Notice:** This mark applies only to countries within the European Union (EU) and Norway.

This appliance is labeled in accordance with European Directive 2002/96/EC concerning waste electrical and electronic equipment (WEEE). The Directive determines the framework for the return and recycling of used appliances as applicable throughout the European Union. This label is applied to various products to indicate that the product is not to be thrown away, but rather reclaimed upon end of life per this Directive.

注意: このマークは EU 諸国およびノルウェーにおいてのみ適用されます。

この機器には、EU 諸国に対する廃電気電子機器指令 2002/96/EC(WEEE) のラベルが貼られています。この指令は、EU 諸国に適用する使用済み機器の回収とリサイクルの骨子を定めています。このラベルは、使用済みになった時に指令に従って適正な処理をする必要があることを知らせるために種々の製品に貼られています。

**Remarque :** Cette marque s'applique uniquement aux pays de l'Union Européenne et à la Norvège.

L'étiquette du système respecte la Directive européenne 2002/96/EC en matière de Déchets des Equipements Electriques et Electroniques (DEEE), qui détermine les dispositions de retour et de recyclage applicables aux systèmes utilisés à travers l'Union européenne. Conformément à la directive, ladite étiquette précise que le produit sur lequel elle est apposée ne doit pas être jeté mais être récupéré en fin de vie.

In accordance with the European WEEE Directive, electrical and electronic equipment (EEE) is to be collected separately and to be reused, recycled, or recovered at end of life. Users of EEE with the WEEE marking per Annex IV of the WEEE Directive, as shown above, must not dispose of end of life EEE as unsorted municipal waste, but use the collection framework available to customers for the return, recycling, and recovery of WEEE. Customer participation is important to minimize any potential effects of EEE on the environment and human health due to the potential presence of hazardous substances in EEE. For proper collection and treatment, contact your local IBM representative.

---

## Battery return program

This product may contain a sealed lead acid, nickel cadmium, nickel metal hydride, lithium, or lithium ion battery. Consult your user manual or service manual for specific battery information. The battery must be recycled or disposed of properly. Recycling facilities may not be available in your area. For information on disposal of batteries outside the United States, go to <http://www.ibm.com/ibm/environment/products/index.shtml> or contact your local waste disposal facility.

In the United States, IBM has established a return process for reuse, recycling, or proper disposal of used IBM sealed lead acid, nickel cadmium, nickel metal hydride, and battery packs from IBM equipment. For information on proper disposal of these batteries, contact IBM at 1-800-426-4333. Have the IBM part number listed on the battery available prior to your call.

**For Taiwan:** Please recycle batteries.



**For the European Union:**



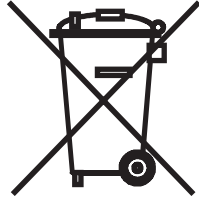

**Notice:** This mark applies only to countries within the European Union (EU).

Batteries or packaging for batteries are labeled in accordance with European Directive 2006/66/EC concerning batteries and accumulators and waste batteries and accumulators. The Directive determines the framework for the return and recycling of used batteries and accumulators as applicable throughout the European Union. This label is applied to various batteries to indicate that the battery is not to be thrown away, but rather reclaimed upon end of life per this Directive.

Les batteries ou emballages pour batteries sont étiquetés conformément aux directives européennes 2006/66/EC, norme relative aux batteries et accumulateurs en usage et aux batteries et accumulateurs usés. Les directives déterminent la marche à suivre en vigueur dans l'Union Européenne pour le retour et le recyclage des batteries et accumulateurs usés. Cette étiquette est appliquée sur diverses batteries pour indiquer que la batterie ne doit pas être mise au rebut mais plutôt récupérée en fin de cycle de vie selon cette norme.

バッテリーあるいはバッテリー用のパッケージには、EU 諸国に対する廃電気電子機器指令 2006/66/EC のラベルが貼られています。この指令は、バッテリーと蓄電池、および廃棄バッテリーと蓄電池に関するものです。この指令は、使用済みバッテリーと蓄電池の回収とリサイクルの骨子を定めているもので、EU 諸国にわたって適用されます。このラベルは、使用済みになったときに指令に従って適正な処理をする必要があることを知らせるために種々のバッテリーに貼られています。

In accordance with the European Directive 2006/66/EC, batteries and accumulators are labeled to indicate that they are to be collected separately and recycled at end of life. The label on the battery may also include a chemical symbol for the metal concerned in the battery (Pb for lead, Hg for mercury, and Cd for cadmium). Users of batteries and accumulators must not dispose of batteries and accumulators as unsorted municipal waste, but use the collection framework available to customers for the return, recycling, and treatment of batteries and accumulators. Customer participation is important to minimize any potential effects of batteries and accumulators on the environment and human health due to the potential presence of hazardous substances. For proper collection and treatment, contact your local IBM representative.

**For California:**

Perchlorate material – special handling may apply. See <http://www.dtsc.ca.gov/hazardouswaste/perchlorate/>.

The foregoing notice is provided in accordance with California Code of Regulations Title 22, Division 4.5 Chapter 33. Best Management Practices for Perchlorate Materials. This product/part may include a lithium manganese dioxide battery which contains a perchlorate substance.

---

## Electronic emission notices

### Federal Communications Commission (FCC) statement

**Note:** This equipment has been tested and found to comply with the limits for a Class A digital device, pursuant to Part 15 of the FCC Rules. These limits are designed to provide reasonable protection against harmful interference when the equipment is operated in a commercial environment. This equipment generates, uses, and can radiate radio frequency energy and, if not installed and used in accordance with the instruction manual, may cause harmful interference to radio communications. Operation of this equipment in a residential area is likely to cause harmful interference, in which case the user will be required to correct the interference at his own expense.

Properly shielded and grounded cables and connectors must be used in order to meet FCC emission limits. IBM is not responsible for any radio or television interference caused by using other than recommended cables and connectors or by unauthorized changes or modifications to this equipment. Unauthorized changes or modifications could void the user's authority to operate the equipment.

This device complies with Part 15 of the FCC Rules. Operation is subject to the following two conditions: (1) this device may not cause harmful interference, and (2) this device must accept any interference received, including interference that may cause undesired operation.

### Industry Canada Class A emission compliance statement

This Class A digital apparatus complies with Canadian ICES-003.

### Avis de conformité à la réglementation d'Industrie Canada

Cet appareil numérique de la classe A est conforme à la norme NMB-003 du Canada.

### Australia and New Zealand Class A statement

**Attention:** This is a Class A product. In a domestic environment this product may cause radio interference in which case the user may be required to take adequate measures.

### United Kingdom telecommunications safety requirement

#### Notice to Customers

This apparatus is approved under approval number NS/G/1234/J/100003 for indirect connection to public telecommunication systems in the United Kingdom.

### European Union EMC Directive conformance statement

This product is in conformity with the protection requirements of EU Council Directive 2004/108/EC on the approximation of the laws of the Member States relating to electromagnetic compatibility. IBM cannot accept responsibility for any failure to satisfy the protection requirements resulting from a nonrecommended modification of the product, including the fitting of non-IBM option cards.

This product has been tested and found to comply with the limits for Class A Information Technology Equipment according to CISPR 22/European Standard EN

55022. The limits for Class A equipment were derived for commercial and industrial environments to provide reasonable protection against interference with licensed communication equipment.

**Attention:** This is a Class A product. In a domestic environment this product may cause radio interference in which case the user may be required to take adequate measures.

European Community contact:  
IBM Technical Regulations  
Pascalstr. 100, Stuttgart, Germany 70569  
Telephone: 0049 (0)711 785 1176  
Fax: 0049 (0)711 785 1283  
E-mail: tjahn@de.ibm.com

### Taiwanese Class A warning statement

警告使用者：  
這是甲類的資訊產品，在  
居住的環境中使用時，可  
能會造成射頻干擾，在這  
種情況下，使用者會被要  
求採取某些適當的對策。

### Chinese Class A warning statement

聲 明  
此為 A 級產品。在生活環境中，  
該產品可能會造成無線電干擾。  
在這種情況下，可能需要用戶對其  
干擾採取切实可行的措施。

### Japanese Voluntary Control Council for Interference (VCCI) statement

この装置は、情報処理装置等電波障害自主規制協議会（VCCI）の基準に  
基づくクラスA情報技術装置です。この装置を家庭環境で使用すると電波妨害を  
引き起こすことがあります。この場合には使用者が適切な対策を講ずるよう要求  
されることがあります。

## Korean Class A warning statement

이 기기는 업무용으로 전자파 적합등록을 받은 기기 이오니, 판매자 또는 사용자는 이점을 주의하시기 바라며, 만약 잘못 구입하셨을 때에는 구입한 곳에서 비업무용으로 교환하시기 바랍니다.

---

# Index

## A

assistance, getting 55  
attention notices 3

## B

battery return program 78

## C

caution statements 3  
Class A electronic emission notice 80  
components and controls, PDU front 6  
Configuration Utility  
    using to configure PDU 31  
connecting the PDU  
    to a LAN 25  
    to an environmental monitoring probe 26  
    to output devices 26  
    to the console 25  
CRU part numbers 49

## D

danger statements 3  
documentation CD 1

## E

electronic emission Class A notice 80  
environmental monitoring probe  
    connecting to PDU 26  
    features 45  
    installing 46  
    using 45

## F

FCC Class A notice 80  
features of PDU 5

## G

getting help 55  
green LED 6

## H

hardware service and support 56  
help, getting 55

## I

IBM Support Line 56  
important notices 3  
installation requirements 3

## L

LED, green 6  
load groups, PDU 8

## M

monitoring power status 27

## N

notes 3  
notes, important 76  
notices 75  
    electronic emission 80  
    FCC, Class A 80  
notices and statements 3

## O

option package contents 4

## P

parts that come with PDU 4  
PDU  
    connecting an environmental monitoring probe 26  
    connecting output devices 26  
    connecting the console 25  
    connecting the power cord 13, 17  
    connecting to a LAN 25  
    CRU part numbers 49  
    features 5  
    front view components and controls 6  
    installation requirements 3  
    load groups 8  
    monitoring power status 27  
    parts that come with 4  
    rear view 8  
    specifications 51  
    starting Web interface 33  
    using Configuration Utility 31  
    using terminal program to configure 28  
    vertical mounting in rack cabinet 12  
power cord, connecting 17  
power status, monitoring 27  
product recycling and disposal 77

## R

rack-mounting  
    vertical 12  
recycling and disposal, product 77  
requirements, installation 3  
RJ-45 console connector 7  
routing power cords (vertical rack-mounting) 15

## S

- setting PDU IP address
  - using Configuration Utility 32
  - using Web interface 42
- software service and support 56
- specifications, PDU 51
- statements and notices 3
- support, web site 55

## T

- telephone numbers 56
- terminal program, using to configure PDU 28
- trademarks 75

## U

- United States electronic emission Class A notice 80
- United States FCC Class A notice 80

## W

- Web interface
  - Environment page
    - changing configuration 35
    - viewing status 34
  - History page
    - viewing history log 43
  - Network page
    - changing network configuration 42
  - starting 33
  - System page
    - adding users 38
    - changing date and time 39
    - changing event alerts 40
    - changing superuser name and password 36
    - viewing power management information 37
- web site
  - publication ordering 55
  - support 55
  - support line, telephone numbers 56





Part Number: 43V6030

Printed in USA

(1P) P/N: 43V6030

