

Lenovo NeXtScale n1200 Enclosure Installation and Service Guide

Machine Type: 5456

Note

Before using this information and the product it supports, read the general information in [Appendix B “Getting help and technical assistance” on page 123](#), [Appendix C “Notices” on page 127](#), the *Warranty Information* document, and the *Safety Information* and *Environmental Notices and User Guide* documents.

Tenth Edition (June 2022)

© Copyright Lenovo 2015, 2022.

LIMITED AND RESTRICTED RIGHTS NOTICE: If data or software is delivered pursuant to a General Services Administration (GSA) contract, use, reproduction, or disclosure is subject to restrictions set forth in Contract No. GS-35F-05925.

Contents

| | |
|---------------------------|----------|
| Contents | i |
|---------------------------|----------|

| | |
|-------------------------|-------------|
| Safety | .iii |
|-------------------------|-------------|

| | |
|--|----|
| Guidelines for trained service technicians | iv |
| Inspecting for unsafe conditions | iv |
| Guidelines for servicing electrical equipment. | v |
| Safety statements | vi |

| | |
|--|----------|
| Chapter 1. The NeXtScale n1200 Enclosure Types 5456 | 1 |
|--|----------|

| | |
|--|----|
| The Documentation CD | 3 |
| Hardware and software requirements | 3 |
| The Documentation Browser | 3 |
| Related documentation | 4 |
| Brocade documentation | 5 |
| Notices and statements in this document. | 5 |
| Features and specifications | 6 |
| Major chassis components | 8 |
| Front view | 9 |
| Rear view | 10 |

| | |
|--|-----------|
| Chapter 2. Parts listing, NeXtScale n1200 Enclosure Types 5456. | 17 |
|--|-----------|

| | |
|---|----|
| Replaceable server components | 17 |
| Structural parts | 20 |
| Power cords | 20 |

| | |
|---|-----------|
| Chapter 3. Removing and replacing components | 23 |
|---|-----------|

| | |
|---|----|
| Installation guidelines | 23 |
| System reliability guidelines | 24 |
| Handling static-sensitive devices | 25 |
| Returning a device or component | 25 |
| Removing and replacing structural parts | 25 |
| Removing the shipping bracket | 25 |
| Replacing the shipping bracket | 26 |
| Removing and replacing Tier 1 CRUs | 27 |
| Removing a 1-bay compute node | 27 |
| Replacing a 1-bay compute node | 28 |
| Removing a fan module | 29 |
| Replacing a fan module | 30 |
| Removing the fan power control | 31 |
| Replacing an fan power control | 32 |
| Removing the battery from the fan power control | 33 |
| Replacing the battery in the fan power control | 35 |

| | |
|--|----|
| Removing the USB flash drive | 37 |
| Installing the USB flash drive | 37 |
| Removing a hot-swap DC power supply | 38 |
| Replacing a hot-swap DC power supply | 41 |
| Removing an AC power supply | 46 |
| Replacing an AC power supply | 47 |
| Removing and replacing FRUs | 55 |
| Removing the chassis midplane. | 55 |
| Replacing the chassis midplane. | 58 |

| | |
|---|-----------|
| Chapter 4. Using the web interface | 63 |
|---|-----------|

| | |
|---|----|
| Starting the web interface | 63 |
| Resetting the FPC to manufacturing defaults | 63 |

| | |
|---|-----------|
| Chapter 5. Web interface options | 65 |
|---|-----------|

| | |
|--------------------------------------|----|
| Summary options | 65 |
| Power options | 66 |
| Cooling options | 70 |
| System information options | 71 |
| Events log options | 73 |
| Configuration options | 74 |

| | |
|---|-----------|
| Appendix A. Fan power control (FPC) error codes. | 83 |
|---|-----------|

| | |
|---|----|
| List of fan power control (FPC) error codes | 84 |
|---|----|

| | |
|--|------------|
| Appendix B. Getting help and technical assistance | 123 |
|--|------------|

| | |
|--|-----|
| Before you call | 123 |
| Using the documentation | 124 |
| Getting help and information from the World Wide Web | 124 |
| How to send DSA data | 124 |
| Creating a personalized support web page | 124 |
| Software service and support | 124 |
| Hardware service and support | 125 |
| Taiwan product service | 125 |

| | |
|---------------------------------------|------------|
| Appendix C. Notices. | 127 |
|---------------------------------------|------------|

| | |
|---|-----|
| Trademarks | 127 |
| Important notes | 128 |
| Recycling information | 128 |
| Particulate contamination | 129 |
| Telecommunication regulatory statement | 130 |
| Electronic emission notices | 130 |
| Federal Communications Commission (FCC) statement | 130 |

| | |
|--|-----|
| Industry Canada Class A emission compliance statement | 130 |
| Avis de conformité à la réglementation d'Industrie Canada. | 130 |
| Australia and New Zealand Class A statement | 130 |
| European Union EMC Directive conformance statement | 130 |
| Germany Class A statement | 131 |
| Japanese electromagnetic compatibility statements | 132 |
| Korea Communications Commission (KCC) statement | 133 |

| | |
|--|-----|
| Russia Electromagnetic Interference (EMI) Class A statement | 133 |
| People's Republic of China Class A electronic emission statement | 133 |
| Taiwan Class A compliance statement | 133 |
| Taiwan BSMI RoHS declaration. | 134 |

Appendix D. German Ordinance for Work gloss statement135

Index137

Safety

Before installing this product, read the Safety Information.

قبل تركيب هذا المنتج، يجب قراءة الملاحظات الأمنية

Antes de instalar este produto, leia as Informações de Segurança.

在安裝本產品之前，請仔細閱讀 **Safety Information**
(安全信息)。

安裝本產品之前，請先閱讀「安全資訊」。

Prije instalacije ovog produkta obavezno pročitajte Sigurnosne Upute.

Před instalací tohoto produktu si přečtěte příručku bezpečnostních instrukcí.

Læs sikkerhedsforskrifterne, før du installerer dette produkt.

Lees voordat u dit product installeert eerst de veiligheidsvoorschriften.

Ennen kuin asennat tämän tuotteen, lue turvaohjeet kohdasta Safety Information.

Avant d'installer ce produit, lisez les consignes de sécurité.

Vor der Installation dieses Produkts die Sicherheitshinweise lesen.

Πριν εγκαταστήσετε το προϊόν αυτό, διαβάστε τις πληροφορίες ασφάλειας
(safety information).

לפני שתתקינו מוצר זה, קראו את הוראות הבטיחות.

A termék telepítése előtt olvassa el a Biztonsági előírásokat!

Prima di installare questo prodotto, leggere le Informazioni sulla Sicurezza.

製品の設置の前に、安全情報をお読みください。

본 제품을 설치하기 전에 안전 정보를 읽으십시오.

Пред да се инсталира овој продукт, прочитајте информацијата за безбедност.

بِسْمِ اللَّهِ الرَّحْمَنِ الرَّحِيمِ
بِسْمِ اللَّهِ الرَّحْمَنِ الرَّحِيمِ
بِسْمِ اللَّهِ الرَّحْمَنِ الرَّحِيمِ
بِسْمِ اللَّهِ الرَّحْمَنِ الرَّحِيمِ
بِسْمِ اللَّهِ الرَّحْمَنِ الرَّحِيمِ
بِسْمِ اللَّهِ الرَّحْمَنِ الرَّحِيمِ
بِسْمِ اللَّهِ الرَّحْمَنِ الرَّحِيمِ
بِسْمِ اللَّهِ الرَّحْمَنِ الرَّحِيمِ
بِسْمِ اللَّهِ الرَّحْمَنِ الرَّحِيمِ
بِسْمِ اللَّهِ الرَّحْمَنِ الرَّحِيمِ

Les sikkerhetsinformasjonen (Safety Information) før du installerer dette produktet.

Przed zainstalowaniem tego produktu, należy zapoznać się
z książką "Informacje dotyczące bezpieczeństwa" (Safety Information).

Antes de instalar este produto, leia as Informações sobre Segurança.

Перед установкой продукта прочтите инструкции по технике безопасности.

Pred inštaláciou tohto zariadenia si pečítajte Bezpečnostné predpisy.

Pred namestitvijo tega proizvoda preberite Varnostne informacije.

Antes de instalar este producto, lea la información de seguridad.

Läs säkerhetsinformationen innan du installerar den här produkten.

ཐོན་ཁུངས་འདི་བདེ་སྤྱོད་མ་བྱས་གོང་། རྒྱུ་རྐྱེད་ཡིད་གཟབ་
བྱ་འདྲ་མིན་ཡོད་པའི་འོད་སྤེར་བལྟ་དགོས།

Bu ürünü kurmadan önce güvenlik bilgilerini okuyun.

مەزكۇر مەھسۇلاتنى ئورنىتىشتىن بۇرۇن بىخەتەرلىك ئۇچۇرلىرىنى ئوقۇپ چىقىڭ.

Youq mwngz yungh canjbinj neix gaxgonq, itdingh aeu doeg aen
canjbinj soengq cungj vahgangj ancien siusik.

Guidelines for trained service technicians

This section contains information for trained service technicians.

Inspecting for unsafe conditions

Use this information to help you identify potential unsafe conditions in an IBM producta device that you are working on.

Each IBM productThis device, as it was designed and manufactured, has required safety items to protect users and service technicians from injury. The information in this section addresses only those items. Use good judgment to identify potential unsafe conditions that might be caused by non-IBMunsupported alterations or attachment of non-IBMunsupported features or optional devices that are not addressed in this section. If you identify an unsafe condition, you must determine how serious the hazard is and whether you must correct the problem before you work on the product.

Consider the following conditions and the safety hazards that they present:

- Electrical hazards, especially primary power. Primary voltage on the frame can cause serious or fatal electrical shock.
- Explosive hazards, such as a damaged CRT face or a bulging capacitor.
- Mechanical hazards, such as loose or missing hardware.

To inspect the product for potential unsafe conditions, complete the following steps:

1. Make sure that the power is off and the power cords are disconnected.
2. Make sure that the exterior cover is not damaged, loose, or broken, and observe any sharp edges.
3. Check the power cords:
 - Make sure that the third-wire ground connector is in good condition. Use a meter to measure third-wire ground continuity for 0.1 ohm or less between the external ground pin and the frame ground.
 - Make sure that the power cords are the correct type.
 - Make sure that the insulation is not frayed or worn.

4. Remove the cover.
5. Check for any obvious non-IBMunsupported alterations. Use good judgment as to the safety of any non-IBMunsupported alterations.
6. Check inside the system for any obvious unsafe conditions, such as metal filings, contamination, water or other liquid, or signs of fire or smoke damage.
7. Check for worn, frayed, or pinched cables.
8. Make sure that the power-supply cover fasteners (screws or rivets) have not been removed or tampered with.

Guidelines for servicing electrical equipment

Observe these guidelines when you service electrical equipment.

- Check the area for electrical hazards such as moist floors, nongrounded power extension cords, and missing safety grounds.
- Use only approved tools and test equipment. Some hand tools have handles that are covered with a soft material that does not provide insulation from live electrical current.
- Regularly inspect and maintain your electrical hand tools for safe operational condition. Do not use worn or broken tools or testers.
- Do not touch the reflective surface of a dental mirror to a live electrical circuit. The surface is conductive and can cause personal injury or equipment damage if it touches a live electrical circuit.
- Some rubber floor mats contain small conductive fibers to decrease electrostatic discharge. Do not use this type of mat to protect yourself from electrical shock.
- Do not work alone under hazardous conditions or near equipment that has hazardous voltages.
- Locate the emergency power-off (EPO) switch, disconnecting switch, or electrical outlet so that you can turn off the power quickly in the event of an electrical accident.
- Disconnect all power before you perform a mechanical inspection, work near power supplies, or remove or install main units.
- Before you work on the equipment, disconnect the power cord. If you cannot disconnect the power cord, have the customer power-off the wall box that supplies power to the equipment and lock the wall box in the off position.
- Never assume that power has been disconnected from a circuit. Check it to make sure that it has been disconnected.
- If you have to work on equipment that has exposed electrical circuits, observe the following precautions:
 - Make sure that another person who is familiar with the power-off controls is near you and is available to turn off the power if necessary.
 - When you work with powered-on electrical equipment, use only one hand. Keep the other hand in your pocket or behind your back to avoid creating a complete circuit that could cause an electrical shock.
 - When you use a tester, set the controls correctly and use the approved probe leads and accessories for that tester.
 - Stand on a suitable rubber mat to insulate you from grounds such as metal floor strips and equipment frames.
- Use extreme care when you measure high voltages.
- To ensure proper grounding of components such as power supplies, pumps, blowers, fans, and motor generators, do not service these components outside of their normal operating locations.
- If an electrical accident occurs, use caution, turn off the power, and send another person to get medical aid.

Safety statements

These statements provide the caution and danger information that is used in this documentation.

Important: Each caution and danger statement in this documentation is labeled with a number. This number is used to cross reference an English-language caution or danger statement with translated versions of the caution or danger statement in the *Safety Information* document.

For example, if a caution statement is labeled Statement 1, translations for that caution statement are in the *Safety Information* document under Statement 1.

Be sure to read all caution and danger statements in this documentation before you perform the procedures. Read any additional safety information that comes with your system or optional device before you install the device.

Statement 1



Electrical current from power, telephone, and communication cables is hazardous.

To avoid a shock hazard:

- **Do not connect or disconnect any cables or perform installation, maintenance, or reconfiguration of this product during an electrical storm.**
- **Connect all power cords to a properly wired and grounded electrical outlet.**
- **Connect to properly wired outlets any equipment that will be attached to this product.**
- **When possible, use one hand only to connect or disconnect signal cables.**
- **Never turn on any equipment when there is evidence of fire, water, or structural damage.**
- **Disconnect the attached power cords, telecommunications systems, networks, and modems before you open the device covers, unless instructed otherwise in the installation and configuration procedures.**
- **Connect and disconnect cables as described in the following table when installing, moving, or opening covers on this product or attached devices.**

Table for Safety Statement 1 that explains the steps to connect and disconnect cables.

To Connect:

1. Turn everything OFF.
2. First, attach all cables to devices.
3. Attach signal cables to connectors.
4. Attach power cords to outlet.
5. Turn device ON.

To Disconnect:

1. Turn everything OFF.
2. First, remove power cords from outlet.
3. Remove signal cables from connectors.
4. Remove all cables from devices.

Statement 2



CAUTION:

When replacing the lithium battery, use only Part Number 33F8354 or an equivalent type battery recommended by the manufacturer. If your system has a module containing a lithium battery, replace it only with the same module type made by the same manufacturer. The battery contains lithium and can explode if not properly used, handled, or disposed of. *Do not:*

- Throw or immerse into water
- Heat to more than 100°C (212°F)
- Repair or disassemble

Dispose of the battery as required by local ordinances or regulations.

Statement 3



CAUTION:

When laser products (such as CD-ROMs, DVD drives, fiber optic devices, or transmitters) are installed, note the following:

- Do not remove the covers. Removing the covers of the laser product could result in exposure to hazardous laser radiation. There are no serviceable parts inside the device.
- Use of controls or adjustments or performance of procedures other than those specified herein might result in hazardous radiation exposure.



Some laser products contain an embedded Class 3A or Class 3B laser diode. Note the following. Laser radiation when open. Do not stare into the beam, do not view directly with optical instruments, and avoid direct exposure to the beam.

Statement 4



Three graphic illustrations for safety practices when lifting.

CAUTION: Use safe practices when lifting.

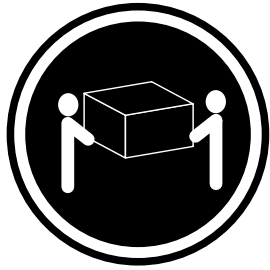

≥ 18 kg (39.7 lb)

≥ 32 kg (70.5 lb)

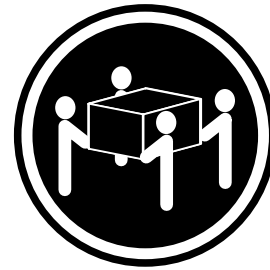

≥ 55 kg (121.2 lb)

Statement 5



CAUTION:

The power control button on the device and the power switch on the power supply do not turn off the electrical current supplied to the device. The device also might have more than one power cord. To remove all electrical current from the device, ensure that all power cords are disconnected from the power source.



Statement 6



CAUTION:

If you install a strain-relief bracket option over the end of the power cord that is connected to the device, you must connect the other end of the power cord to an easily accessible power source.

Statement 7



CAUTION:

If the device has doors, be sure to remove or secure the doors before moving or lifting the device to avoid personal injury. The doors will not support the weight of the device.

Statement 8



CAUTION:

Never remove the cover on a power supply or any part that has the following label attached.

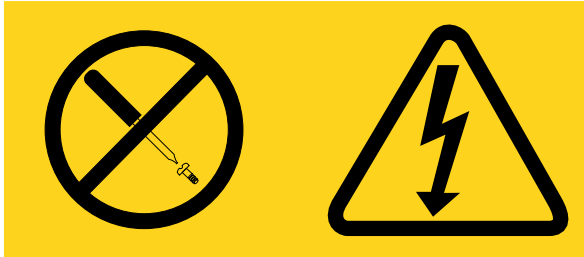

Hazardous voltage, current, and energy levels are present inside any component that has this label attached. There are no serviceable parts inside these components. If you suspect a problem with one of these parts, contact a service technician.

Statement 9



CAUTION:

To avoid personal injury, disconnect the hot-swap fan cables before removing the fan from the device.

Statement 10



CAUTION:

Do not place any object weighing more than 82 kg (180 lb) on top of rack-mounted devices.



>82 kg (180 lb)

Statement 11



CAUTION:

The following label indicates sharp edges, corners, or joints nearby.

Statement 12



CAUTION:

The following label indicates a hot surface nearby.



Statement 13



Overloading a branch circuit is potentially a fire hazard and a shock hazard under certain conditions. To avoid these hazards, ensure that your system electrical requirements do not exceed branch circuit protection requirements. Refer to the information that is provided with your device for electrical specifications.

Statement 14



CAUTION:

Hazardous voltage, current, and energy levels might be present. Only a qualified service technician is authorized to remove the covers where the following label is attached.

Statement 15



CAUTION:

Make sure that the rack is secured properly to avoid tipping when the server unit is extended.

Statement 16



CAUTION:

Some accessory or option board outputs exceed Class 2 or limited power source limits and must be installed with appropriate interconnecting cabling in accordance with the national electric code.

Statement 17



CAUTION:

The following label indicates moving parts nearby.

Statement 18



CAUTION:

To reduce the risk of electric shock or energy hazards:

- This equipment must be installed by trained service personnel in a restricted-access location, as defined by the NEC and IEC 60950, Third Edition, The Standard for Safety of Information Technology Equipment.
- Connect the equipment to a reliably grounded safety extra low voltage (SELV) source. An SELV source is a secondary circuit that is designed so that normal and single fault conditions do not cause the voltages to exceed a safe level (60 V direct current).
- The branch circuit overcurrent protection must be rated at a minimum of 5 A to a maximum of 15 A.
- Use 14 American Wire Gauge (AWG) or 2.5 mm² copper conductor only, not exceeding 3 meters in length.
- Torque the wiring-terminal screws to 12 inch-pounds (1.4 newton-meters).
- Incorporate a readily available approved and rated disconnect device in the field wiring.

Statement 19



CAUTION:

The power-control button on the device does not turn off the electrical current supplied to the device. The device also might have more than one connection to dc power. To remove all electrical current from the device, ensure that all connections to dc power are disconnected at the dc power input terminals.

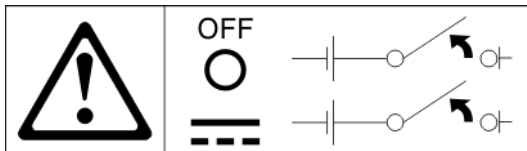

Statement 20



CAUTION:

To avoid personal injury, before lifting the unit, remove all the blades to reduce the weight.

Statement 21



CAUTION:

Hazardous energy is present when the blade is connected to the power source. Always replace the blade cover before installing the blade.

Statement 22



CAUTION:

To reduce the risk of electric shock or energy hazards:

- This equipment must be installed by trained service personnel in a restricted-access location, as defined by the NEC and IEC 60950, Third Edition, The Standard for Safety of Information Technology Equipment.
- Connect the equipment to a reliably grounded safety extra low voltage (SELV) source. An SELV source is a secondary circuit that is designed so that normal and single fault conditions do not cause the voltages to exceed a safe level (60 V direct current).
- The branch circuit overcurrent protection must be rated at a minimum of 13 A to a maximum of 15 A.
- Use 16 American Wire Gauge (AWG) or 1.3 mm² copper conductor only, not exceeding 3 meters in length.
- Torque the wiring-terminal screws to 12 inch-pounds (1.4 newton-meters).
- Incorporate a readily available approved and rated disconnect device in the field wiring.

Statement 23



CAUTION:

Do not place any object weighing more than 50 kg (110 lb) on top of rack-mounted devices.

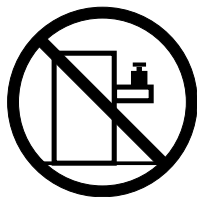

>50 kg (110 lb)

Statement 24



CAUTION:

To reduce the risk of electric shock or energy hazards:

- This equipment must be installed by trained service personnel in a restricted-access location, as defined by the NEC and IEC 60950, Third Edition, The Standard for Safety of Information Technology Equipment.
- Connect the equipment to a reliably grounded safety extra low voltage (SELV) source. An SELV source is a secondary circuit that is designed so that normal and single fault conditions do not cause the voltages to exceed a safe level (60 V direct current).
- The branch circuit overcurrent protection must be rated at a minimum of 12 A to a maximum of 15 A.
- Use 14 American Wire Gauge (AWG) or 2.5 mm² copper conductor only, not exceeding 3 meters in length.
- Torque the wiring-terminal screws to 12 inch-pounds (1.4 newton-meters).
- Incorporate a readily available approved and rated disconnect device in the field wiring.

Statement 25



CAUTION:

This product contains a Class 1M laser. Do not view directly with optical instruments.

Statement 26



CAUTION:

Do not place any object on top of rack-mounted devices.

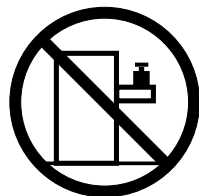

Statement 27



CAUTION:

Hazardous moving parts are nearby.



Statement 28



CAUTION:

The battery is a lithium ion battery. To avoid possible explosion, do not burn the battery. Exchange it only with an approved part. Recycle or discard the battery as instructed by local regulations.

Statement 29



CAUTION:

This equipment is designed to permit the connection of the earthed conductor of the dc supply circuit to the earthing conductor at the equipment. If this connection is made, all of the following conditions must be met:

- This equipment shall be connected directly to the dc supply system earthing electrode conductor or to a bonding jumper from an earthing terminal bar or bus to which the dc supply system earthing electrode conductor is connected.
- This equipment shall be located in the same immediate area (such as, adjacent cabinets) as any other equipment that has a connection between the earthed conductor of the same dc supply circuit and the earthing conductor, and also the point of earthing of the dc system. The dc system shall not be earthed elsewhere.
- The dc supply source shall be located within the same premises as this equipment.
- Switching or disconnecting devices shall not be in the earthed circuit conductor between the dc source and the point of connection of the earthing electrode conductor.

Statement 30



CAUTION:

To reduce the risk of electric shock or energy hazards:

- This equipment must be installed by trained service personnel in a restricted-access location, as defined by the NEC and IEC 60950-1, First Edition, The Standard for Safety of Information Technology Equipment.
- Connect the equipment to a reliably grounded safety extra low voltage (SELV) source. An SELV source is a secondary circuit that is designed so that normal and single fault conditions do not cause the voltages to exceed a safe level (60 V direct current).
- The branch circuit overcurrent protection must be rated 20 A.
- Use 12 American Wire Gauge (AWG) or 2.5 mm² copper conductor only, not exceeding 4.5 meters in length.
- Incorporate a readily available approved and rated disconnect device in the field wiring.

Statement 31



Electrical current from power, telephone, and communication cables is hazardous.

To avoid a shock hazard:

- **Do not connect or disconnect any cables or perform installation, maintenance, or reconfiguration of this product during an electrical storm.**
- **Connect all power cords to a properly wired and grounded power source.**
- **Connect to properly wired power sources any equipment that will be attached to this product.**
- **When possible, use one hand only to connect or disconnect signal cables.**
- **Never turn on any equipment when there is evidence of fire, water, or structural damage.**
- **Disconnect the attached ac power cords, dc power sources, network connections, telecommunications systems, and serial cables before you open the device covers, unless you are instructed otherwise in the installation and configuration procedures.**
- **Connect and disconnect cables as described in the following table when you install, move, or open covers on this product or attached devices.**

To Connect:

1. Turn OFF all power sources and equipment that is to be attached to this product.
2. Attach signal cables to the product.
3. Attach power cords to the product.
 - For ac systems, use appliance inlets.
 - For dc systems, ensure correct polarity of -48 V dc connections: RTN is + and -48 V dc is -. Earth ground should use a two-hole lug for safety.
4. Attach signal cables to other devices.
5. Connect power cords to their sources.
6. Turn ON all the power sources.

To Disconnect:

1. Turn OFF all power sources and equipment that is to be attached to this product.
 - For ac systems, remove all power cords from the chassis power receptacles or interrupt power at the ac power distribution unit.
 - For dc systems, disconnect dc power sources at the breaker panel or by turning off the power source. Then, remove the dc cables.
2. Remove the signal cables from the connectors.
3. Remove all cables from the devices.

Statement 32



CAUTION:

To avoid personal injury, before lifting the unit, remove all the blades, power supplies, and removable modules to reduce the weight.

Statement 33



Statement 33 illustrations and caution statement for disconnecting all power cords.

CAUTION: This device does not provide a power control button. Removing power supply modules or turning off the server blades does not turn off the electrical current supplied to the device. The device also might have more than one power cord. To remove all electrical current from the device, ensure that all power cords are disconnected from the power source.

Statement 34



CAUTION:

To reduce the risk of electric shock or energy hazards:

- This equipment must be installed by trained service personnel in a restricted-access location, as defined by the NEC and IEC 60950-1, First Edition, The Standard for Safety of Information Technology Equipment.
- Connect the equipment to a properly grounded safety extra low voltage (SELV) source. A SELV source is a secondary circuit that is designed so that normal and single fault conditions do not cause the voltages to exceed a safe level (60 V direct current).
- Incorporate a readily available approved and rated disconnect device in the field wiring.
- See the specifications in the product documentation for the required circuit-breaker rating for branch circuit overcurrent protection.
- Use copper wire conductors only. See the specifications in the product documentation for the required wire size.
- See the specifications in the product documentation for the required torque values for the wiring-terminal screws.

Statement 37



When you populate a rack cabinet, adhere to the following guidelines:

- Always lower the leveling pads on the rack cabinet.
- Always install the stabilizer brackets on the rack cabinet.
- Always install the heaviest devices in the bottom of the rack cabinet.
- Do not extend multiple devices from the rack cabinet simultaneously, unless the rack-mounting instructions direct you to do so. Multiple devices extended into the service position can cause your rack cabinet to tip.
- If you are not using the IBM 9308 rack cabinet, securely anchor the rack cabinet to ensure its stability.

Rack Safety Information, Statement 2



 **DANGER**

- **Always lower the leveling pads on the rack cabinet.**
- **Always install stabilizer brackets on the rack cabinet.**
- **Always install servers and optional devices starting from the bottom of the rack cabinet.**
- **Always install the heaviest devices in the bottom of the rack cabinet.**

UL regulatory information

This device is for use only with Listed chassis.

Attention: This product is suitable for use on an IT power distribution system whose maximum phase-to-phase-voltage is 240 V under any distribution fault condition.

Chapter 1. The NeXtScale n1200 Enclosure Types 5456

The NeXtScale n1200 Enclosure Types 5456 chassis is a 6U next-generation server platform with integrated fan power control. It is a compact, high-density, high-performance, rack-mounted, scalable server platform system.

The NeXtScale n1200 Enclosure Types 5456 chassis has twelve node bays. A 1-bay compute node occupies one node bay in the chassis. A 2-bay storage tray or GPU tray occupies two node bays in the chassis. The nodes share common resources, such as power and cooling in the chassis.

The NeXtScale n1200 Enclosure can support the following components:

- Up to twelve 1-bay compute nodes.
- Up to six power supplies.
- Ten fan modules.
- One fan power control.

The chassis system provides the following features:

- **Compute node expansion capabilities**

You can install up to twelve 1-bay compute nodes in the chassis. Some compute nodes have connectors for additional optional devices that you can use to add capabilities to the compute nodes.

- **High-availability design**

The following components in the chassis enable continued operation if one of the components fails:

- **Power supplies**

The power supplies support a single power domain that provides power to all of the chassis components. If a power supply fails, the other power supplies can continue to provide power. The PSU Redundancy mode that you have applied for the chassis determines the result of a power-supply failure.

- **Fan modules**

The fan modules provide cooling to all of the chassis components and the power supplies have their own fans to provide the cooling.

- **Fan power control**

The fan power control enables the Integrated Management Module to monitor the fans and control fan speed.

- **Chassis midplane**

The chassis midplane provides the following features:

- Power distribution to all nodes and modules

The midplane provides hot-swap connectors for the following components:

- Twelve 1-bay compute nodes
- Six power supplies
- Ten fan modules
- Fan power control

Record information about the NeXtScale n1200 Enclosure in the following table. You will need this information for future reference.

Four column table for documenting the product name, machine type, model number, and serial number.

| Product name | Machine Type (s) | Model number | Serial number |
|---------------------------|------------------|--------------|---------------|
| NeXtScale n1200 Enclosure | 5456 | | |

The serial number and model number are on the top, front, and rear of the chassis. The following illustration shows the location of the label on the front of the chassis.

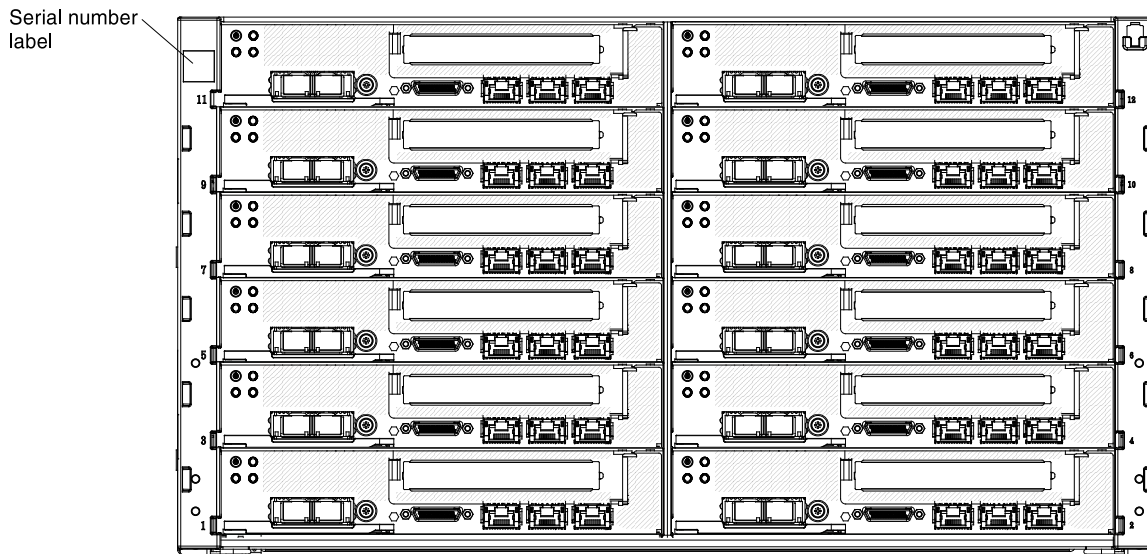

Figure 1. The location of the serial number and model number

If the chassis comes with an RFID tag, it is attached to the upper-left corner of the bezel. The following illustration shows the location of the RFID tag on the front of the chassis.

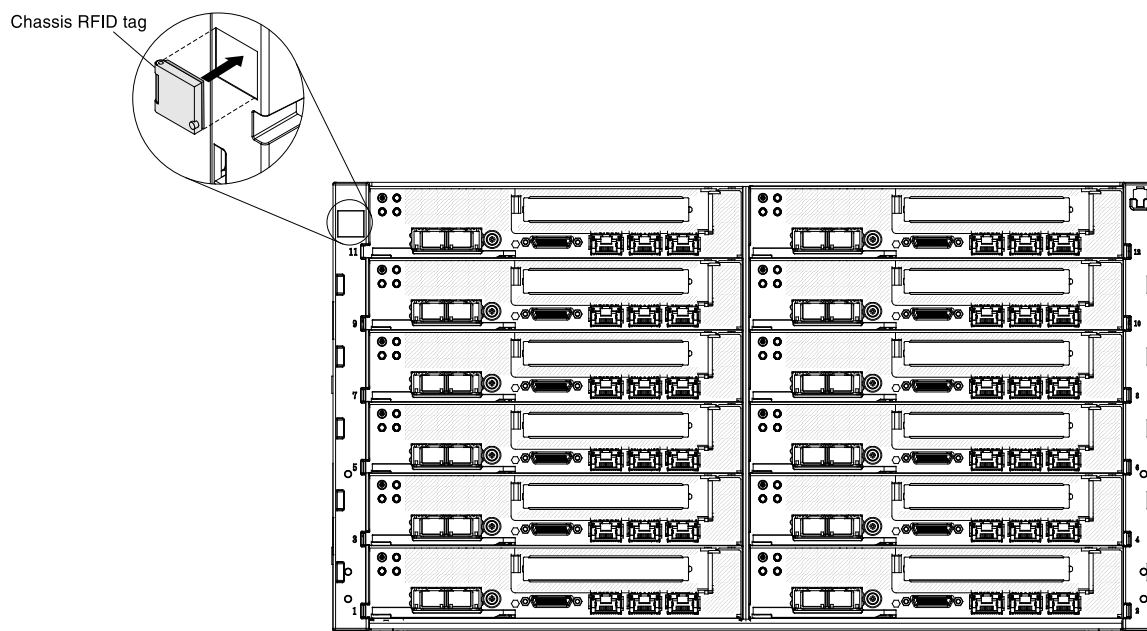

Figure 2. The location of the Chassis RFID tag

The Documentation CD

The *Documentation CD* contains documentation for the server in Portable Document Format (PDF) and includes the Documentation Browser to help you find information quickly.

Hardware and software requirements

The hardware and software requirements of the *Documentation CD*.

The *Documentation CD* requires the following minimum hardware and software:

- Microsoft Windows or Red Hat Linux
- 100 MHz microprocessor
- 32 MB of RAM
- Adobe Acrobat Reader 3.0 (or later) or xpdf, which comes with Linux operating systems

The Documentation Browser

Use the Documentation Browser to browse the contents of the CD, read brief descriptions of the documents, and view documents, using Adobe Acrobat Reader or xpdf.

The Documentation Browser automatically detects the regional settings in use in your server and displays the documents in the language for that region (if available). If a document is not available in the language for that region, the English-language version is displayed. Use one of the following procedures to start the Documentation Browser:

- If Autostart is enabled, insert the CD into the CD or DVD drive. The Documentation Browser starts automatically.
- If Autostart is disabled or is not enabled for all users, use one of the following procedures:
 - If you are using a Windows operating system, insert the CD into the CD or DVD drive and click **Start → Run**. In the Open field, type: `e:\win32.bat` where `e` is the drive letter of the CD or DVD drive, and click **OK**.

- If you are using Red Hat Linux, insert the CD into the CD or DVD drive; then, run the following command from the `/mnt/cdrom` directory: `sh runlinux.sh`

Select the server from the **Product** menu. The **Available Topics** list displays all the documents for the server. Some documents might be in folders. A plus sign (+) indicates each folder or document that has additional documents under it. Click the plus sign to display the additional documents.

When you select a document, a description of the document is displayed under **Topic Description**. To select more than one document, press and hold the Ctrl key while you select the documents. Click **View Book** to view the selected document or documents in Acrobat Reader or xpdf. If you selected more than one document, all the selected documents are opened in Acrobat Reader or xpdf.

To search all the documents, type a word or word string in the **Search** field and click **Search**. The documents in which the word or word string appears are listed in order of the most occurrences. Click a document to view it, and press Ctrl+F to use the Acrobat search function, or press Alt+F to use the xpdf search function within the document.

Click **Help** for detailed information about using the Documentation Browser.

Related documentation

This *Installation and Service Guide* contains general information about the NeXtScale n1200 Enclosure Types 5456 chassis including information to help you solve problems yourself and instructions for removing and installing components, and it contains information for service technicians.

The following documentation is also available:

- *Warranty Information*

This document is in printed format and comes with the server. It contains warranty terms and a pointer to the Statement of Limited Warranty on the website.

- *Important Notices*

This document is in printed format and comes with the server. It contains information about the safety, environmental, and electronic emission notices for your product.

- *Environmental Notices and User Guide*

This document is in PDF format on the *Documentation* CD. It contains translated environmental notices.

- *License Agreement for Machine Code*

This document is in PDF on the *Documentation* CD. It provides translated versions of the *License Agreement for Machine Code* for your product.

- *Licenses and Attributions Document*

This document is in PDF on the *Documentation* CD. It provides the open source notices.

- *Safety Information*

This document is in PDF on the *Documentation* CD. It contains translated caution and danger statements. Each caution and danger statement that appears in the documentation has a number that you can use to locate the corresponding statement in your language in the *Safety Information* document.

- *Rack Installation Instructions*

This printed document contains instructions for installing the server in a rack.

Depending on the server model, additional documentation might be included on the *Documentation* CD.

The ToolsCenter for System x and BladeCenter is an online information center that contains information about tools for updating, managing, and deploying firmware, device drivers, and operating systems. The ToolsCenter for System x and BladeCenter is at <https://support.lenovo.com/us/en/solutions/ht115036>.

The server might have features that are not described in the documentation that you received with the server. The documentation might be updated occasionally to include information about those features, or technical updates might be available to provide additional information that is not included in the server documentation. These updates are available from the website. To check for updates, go to <http://www.lenovo.com/support>.

Brocade documentation

Use this information to identify and locate related Brocade documentation.

The following section introduces Brocade documents that you might find useful for the installation and administration.

- **EN4023 User Guide**

- *Network OS Layer 2 Switching Configuration Guide* - <http://www.brocade.com/content/html/en/configuration-guide/nos-601a-l2guide/>
- *Network OS Command Reference Guide* - <http://www.brocade.com/content/html/en/command-reference-guide/nos-601a-commandref/index.html>
- *Network OS Message Reference* - <http://www.brocade.com/content/html/en/message-reference-guides/nos-601a-messageref/wwhelp/wwhimpl/js/html/wwhelp.htm>

- **FC5022 User Guide**

- *Fabric OS Administrator's Guide* - <http://www.brocade.com/content/html/en/administration-guide/fos-740-adminguide/>
- *Fabric OS Command Reference* - <http://www.brocade.com/content/html/en/command-reference-guide/fos-741-commandref/wwhelp/wwhimpl/js/html/wwhelp.htm>
- *Fabric OS Message Reference* - http://www.brocade.com/content/html/en/message-reference-guides/FOS_740_MESSAGES/wwhelp/wwhimpl/js/html/wwhelp.htm#href=Title.1.2.html
- *Access Gateway Administrator's Guide* - <http://www.brocade.com/content/html/en/administration-guide/fos-740-accessgateway/index.html>

Notices and statements in this document

The caution and danger statements in this document are also in the multilingual *Safety Information* document, which is on the *Documentation* CD. Each statement is numbered for reference to the corresponding statement in your language in the *Safety Information* document.

The following notices and statements are used in this document:

- **Note:** These notices provide important tips, guidance, or advice.
- **Important:** These notices provide information or advice that might help you avoid inconvenient or problem situations.
- **Attention:** These notices indicate potential damage to programs, devices, or data. An attention notice is placed just before the instruction or situation in which damage might occur.
- **Caution:** These statements indicate situations that can be potentially hazardous to you. A caution statement is placed just before the description of a potentially hazardous procedure step or situation.
- **Danger:** These statements indicate situations that can be potentially lethal or extremely hazardous to you. A danger statement is placed just before the description of a potentially lethal or extremely hazardous procedure step or situation.

Features and specifications

Use this information for an overview of the chassis features and specifications.

The following information is a summary of the features and specifications of the chassis. Depending on the model, some features might not be available, or some specifications might not apply.

Node bays (on front):

The chassis has twelve node bays.

Module bays (on rear):

- Six hot-swap power-supply bays
- Ten hot-swap fan bays

Cooling:

Supports ten hot-swap fan modules.

Upgradeable microcode:

Microcode is upgradeable when fixes or features are added.

- Compute node firmwares
- FPC firmware

Power supplies:

- Supports six hot-swap AC and DC power supplies
 - 900-watt AC
 - 1300-watt AC platinum
 - -48V 900-watt DC

Notes:

- Power supplies in the chassis must be with the same input voltage range, power rating, and certification category.
- 1300-watt power supplies support high-line Vin (AC 200V – 240V) only.

Electrical input:

- Sine-wave input (50/60 Hz) required
- Input voltage low range:
 - Minimum: 100 V AC
 - Maximum: 127 V AC
- Input voltage high range:
 - Minimum: 200 V AC
 - Maximum: 240 V AC
- Input kilovolt-amperes (kVA), approximately:
 - Minimum: 0.14 kVA
 - Maximum: 1.19 kVA

Security features:

- Login password for remote connection
- Secure Sockets Layer (SSL) security for remote management access
- Trusted and signed firmware

Predictive Failure Analysis (PFA) alerts:

- Fan modules
- Compute-node dependent features
- Power supply modules

Size (6U):

- Height: 263.3 mm (10.37 in.)
- Depth: 914.5 mm (36 in.)
- Width: 447 mm (17.6 in.)
- Weight:
 - Fully configured (stand-alone): approximately 112 kg (247 lb)
 - Empty chassis (with midplant, FPC, and cables): approximately 28 kg (62 lb)

Approximate heat output::

Approximate heat output:

- Minimum configuration: 1365 Btu per hour (400 watts)
- Maximum configuration: 24,565 Btu per hour (7,200 watts)

Declared sound power level:

- 7.5 bels

Chassis airflow:

Full chassis configuration with all nodes, fan power control, power supplies, and fan modules installed.

- Minimum - 158 CFM (at the idle state)
- Nominal - 213 CFM (at the acoustic fan speed)
- Maximum - 614 CFM (at the fan full speed)

Environment:

The NeXtScale n1200 Enclosure complies with ASHRAE class A3 specifications.

- Power on ¹:
 - Temperature: 5°C - 40°C (41°F - 104°F) ³
 - Humidity, non-condensing: -12°C dew point (10.4°F) and 8% - 85% relative humidity ^{5,6}
 - Maximum dew point: 24°C (75°F)
 - Maximum altitude: 3048 m (10,000 ft)
 - Maximum rate of temperature change: 5°C/hr (41°F/hr) ⁴
- Power off ²:
 - Temperature: 5°C to 45°C (41°F - 113°F)
 - Relative humidity: 8% - 85%
 - Maximum dew point: 27°C (80.6°F)
- Storage (non-operating):
 - Temperature: 1°C to 60°C (33.8°F - 140°F)
 - Altitude: 3050 m (10,006 ft)
 - Relative humidity: 5% - 80%

- Maximum dew point: 29°C (84.2°F)
- Shipment (non-operating) ⁷:
 - Temperature: -40°C to 60°C (-40°F - 140°F)
 - Altitude: 10,700 m (35,105 ft)
 - Relative humidity: 5% - 100%
 - Maximum dew point: 29°C (84.2°F) ⁸

Notes:

1. Chassis is powered on.
2. Chassis is removed from original shipping container and is installed but not in use, for example, during repair, maintenance, or upgrade.
3. A3 - Derate maximum allowable temperature 1°C/175 m above 950 m.
4. 5°C/hr for data centers employing tape drives and 20°C/hr for data centers employing disk drives.
5. The minimum humidity level for class A3 is the higher (more moisture) of the -12 °C dew point and the 8% relative humidity. These intersect at approximately 25°C. Below this intersection (~25C) the dew point (-12 °C) represents the minimum moisture level, while above it relative humidity (8%) is the minimum.
6. Moisture levels lower than 0.5°C DP, but not lower -10 °C DP or 8% relative humidity, can be accepted if appropriate control measures are implemented to limit the generation of static electricity on personnel and equipment in the data center. All personnel and mobile furnishings and equipment must be connected to ground via an appropriate static control system. The following items are considered the minimum requirements:
 - a. Conductive materials (conductive flooring, conductive footwear on all personnel that go into the datacenter, all mobile furnishings and equipment will be made of conductive or static dissipative materials).
 - b. During maintenance on any hardware, a properly functioning wrist strap must be used by any personnel who contacts IT equipment.
7. The equipment acclimation period is 1 hour per 20 °C of temperature change from the shipping environment to the operating environment.
8. Condensation is acceptable, but not rain.
9. Power consumption and heat output vary depending on the number and type of optional features installed and the power-management optional features in use.
10. The noise emission level stated is the declared (upper limit) sound power level, in bels, for a random sample of machines. All measurements are made in accordance with ISO 7779 and reported in conformance with ISO 9296. Actual sound-pressure levels in a given location might exceed the average values stated because of room reflections and other nearby noise sources. The noise emission level stated in the declared (upper limit) sound-power level, in bels, for a random sample of system.

Major chassis components

The following illustration shows the major components in the chassis.

The illustrations in this document might differ slightly from your hardware.

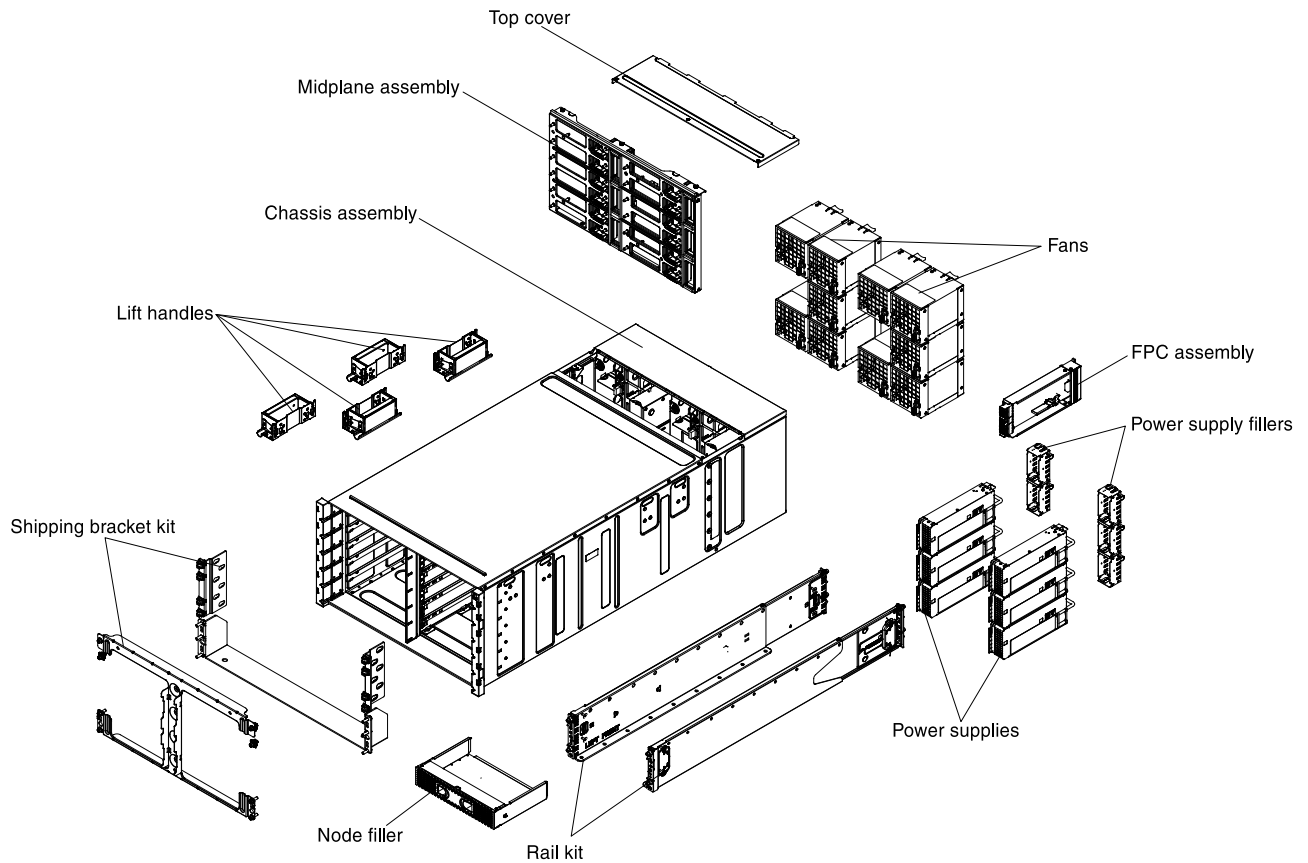

Figure 3. Chassis components

Front view

The following illustration shows the controls and connectors on the front of the server.

For proper cooling, each bay in the chassis must contain either a device or a filler.

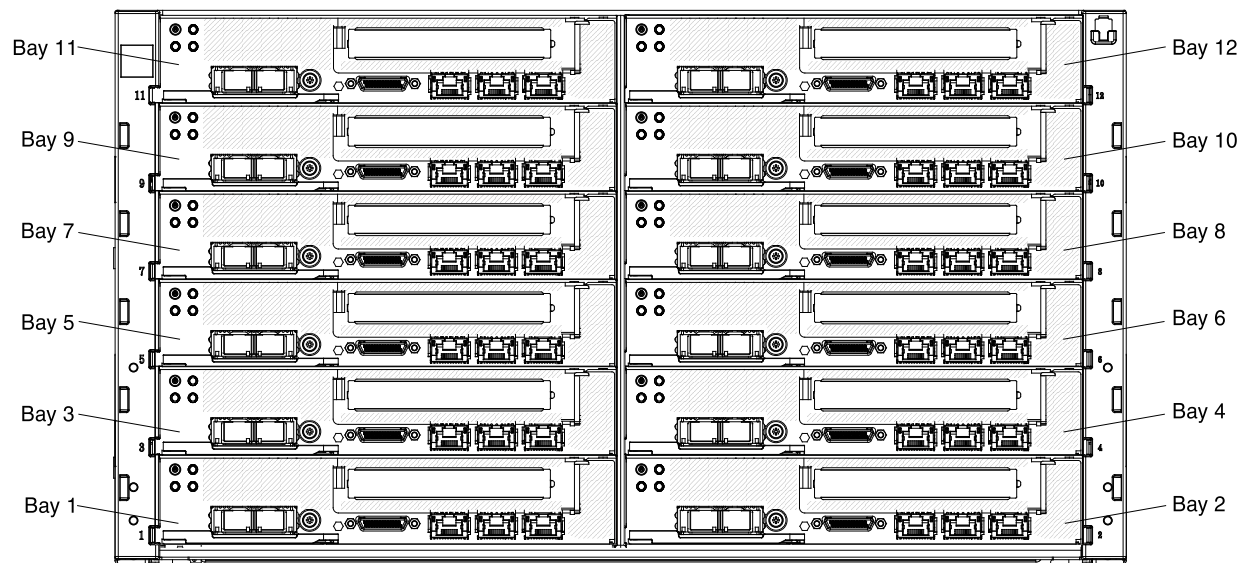

Figure 4. Front view of chassis

Compute nodes

Compute nodes contain components such as microprocessors, memory, and Ethernet controllers. They receive power and network connections from the NeXtScale n1200 Enclosure.

The NeXtScale n1200 Enclosure supports up to twelve 1-bay compute nodes.

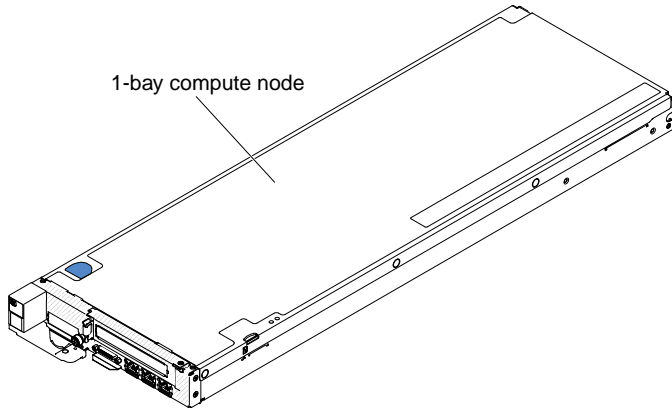

Figure 5. 1-bay compute node

For more information about the compute nodes that are available for the NeXtScale n1200 Enclosure, see https://flexsystem.lenovofiles.com/help/topic/com.lenovo.acc.common.nav.doc/compute_blades.html.

To determine which compute nodes are compatible with the NeXtScale n1200 Enclosure, see <http://static.lenovo.com/us/en/serverproven/index.shtml>.

Rear view

The following illustrations show the connectors on the rear of the chassis.

Fan modules, fan power control, and power supplies are in the rear of the NeXtScale n1200 Enclosure. Each bay in the chassis must contain either a device or a filler.

The following illustration shows the connectors on the rear of the chassis.

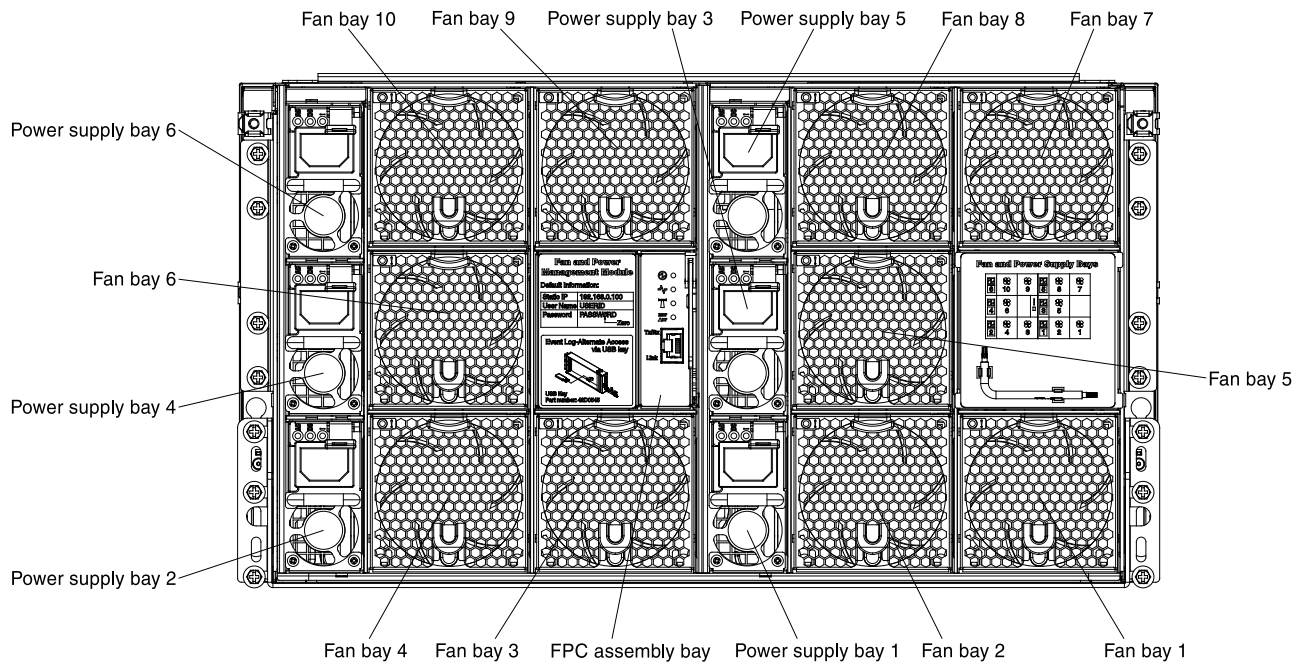

Figure 6. Rear view of chassis

Fan power control (FPC)

You can install the fan power control in the NeXtScale n1200 Enclosure.

The following is an illustration that shows the chassis fan power control bay.

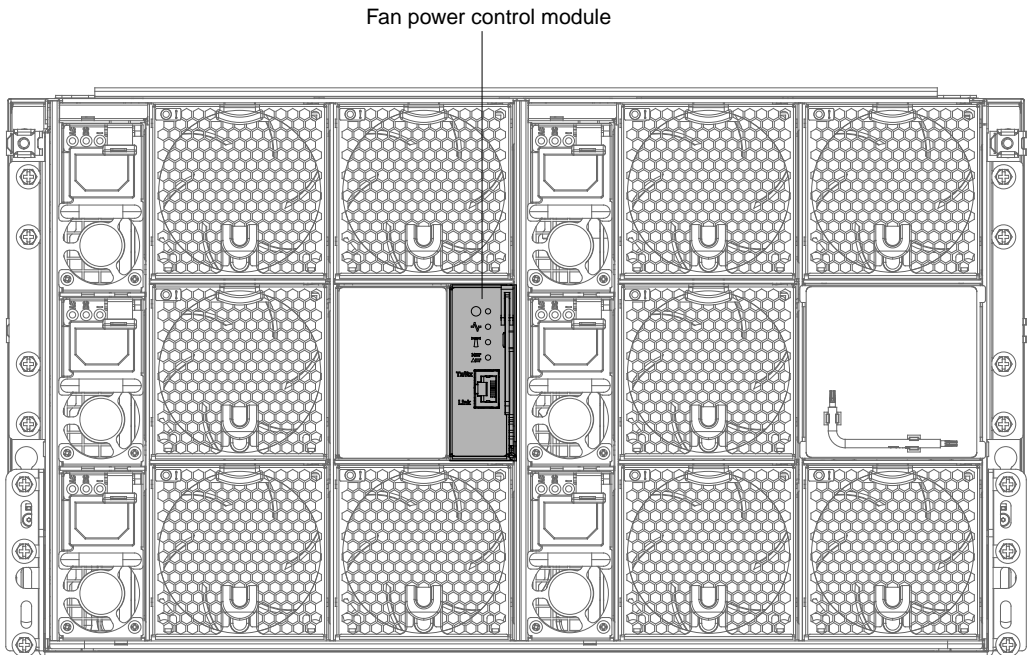

Figure 7. Chassis fan power control bay

The fan power control has fault and power-on LEDs similar to those found on the other chassis components. The fan power control also has connectors that are unique to the device.

The fan power control provides integrated systems-management functions, including a 10/100 Mbps remote management and console (Ethernet) connector.

The following is an illustration of the fan power control:

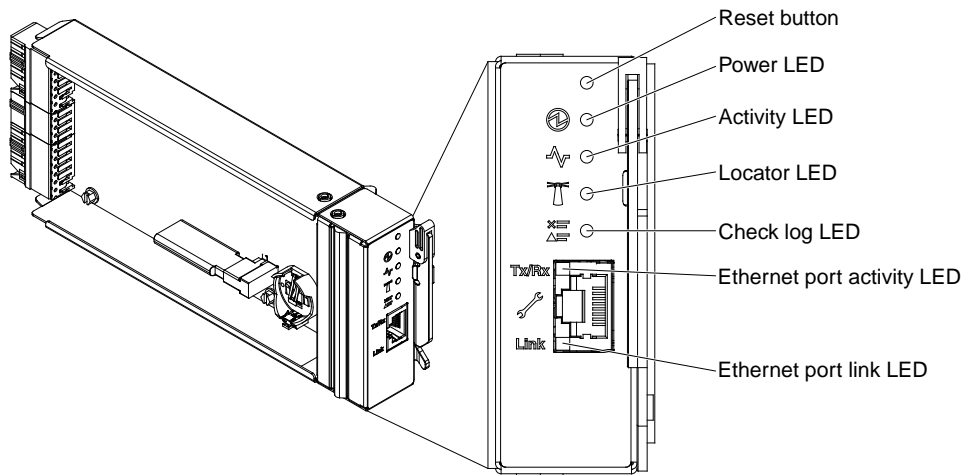

Figure 8. Fan power control with call outs

Fan power control indicators, controls, and connectors

The fan power control has LEDs, controls, and connectors that you can use to obtain status information and restart the fan power control.

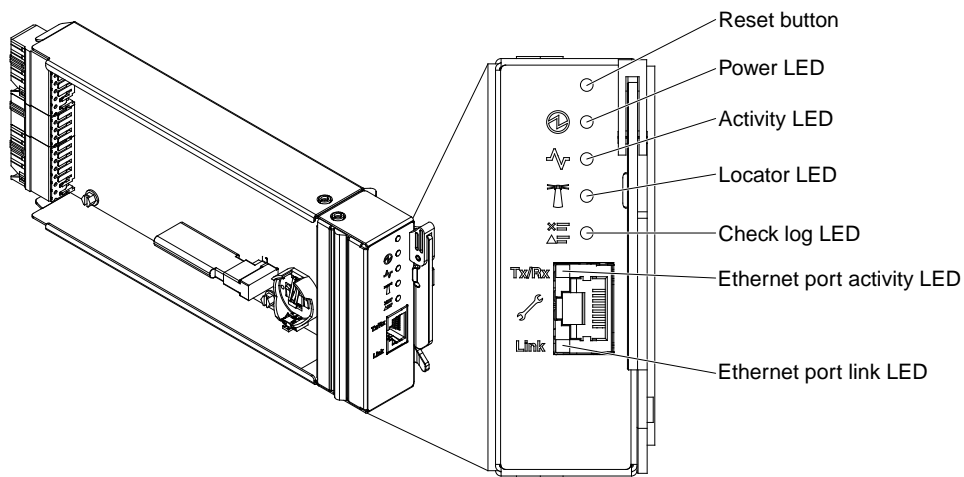

Figure 9. Fan power control with call outs for the LEDs, controls, and connectors

The fan power control has the following LEDs, controls, and connectors:

Power-on LED

When this LED is lit (green), it indicates that the fan power control has power.

Heartbeat LED

When this LED is lit (green), it indicates that the fan power control is actively controlling the chassis.

Locator LED

When this LED is lit (blue), it indicates the chassis location in a rack.

Check log LED

When this LED is lit (yellow), it indicates that a system error has occurred. Check the event log for additional information.

Reset button

Press the button for 1 to 4 seconds, FPC reboots. Press over 4 seconds, FPC reboots and loads to the default settings.

Ethernet port activity (RJ-45) LED

When this LED is flashing (green), it indicates that there is activity through the remote management and console (Ethernet) port over the management network.

Ethernet port link (RJ-45) LED

When this LED is lit (green), it indicates that there is an active connection through the remote management and console (Ethernet) port to the management network.

Remote management and console (Ethernet) connector

The remote management and console connector (RJ-45) is the management network connector for all chassis components. This 10/100 base T Ethernet connector is usually connected to the management network through a top-of-rack switch.

Power supplies

The NeXtScale n1200 Enclosure supports six autoranging power supplies.

The following illustration shows the AC power supply:

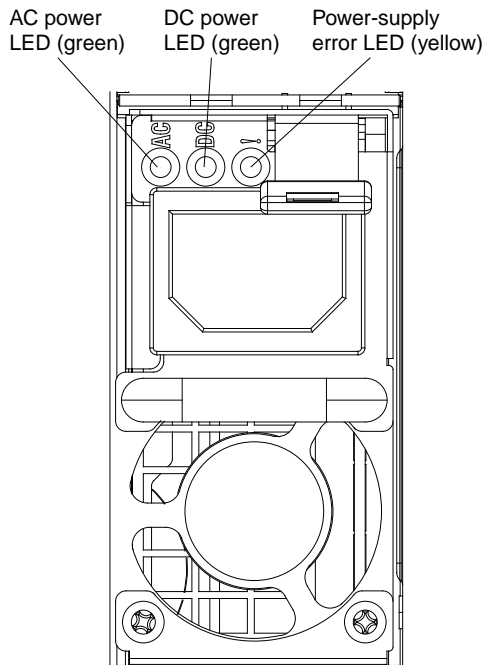

Figure 10. Power supply front view

The AC power supplies get electrical power from a 100 - 127 V AC or 200 - 240 V AC power source and convert the AC input into 12 V outputs. The power supplies are capable of autoranging within the input voltage range. There is one common power domain for the chassis that distributes power to each of the nodes and modules through the system midplane.

AC redundancy is achieved by distributing the AC power cord connections between independent AC circuits.

When applying the power supplies redundancy policy through fan power control after the nodes are powered on, it may not be sufficient to allow N+1 or N+N configuration at current power supplies redundancy state. Before you change the power supplies redundancy policy, you may use the Power Configurator utility to determine current system power consumption. For more information and to download the utility, go to <https://pcsupport.lenovo.com/us/en/downloads/ds112002>.

Notes:

- Power supplies in the chassis must be with the same input voltage range, power rating, and certification category.
- 1300-watt power supplies support high-line Vin (AC 200V – 240V) only.

Each power supply has internal fans and a controller. The power supply controller can be powered by any installed power supply that is providing power through the midplane.

Attention: The power supplies contain internal cooling fans. Do not obstruct the fan exhaust vents.

The NeXtScale n1200 Enclosure does not support mixing of low input voltage power supplies with high input voltage power supplies. For example, if you install a power supply with an input voltage of 100 - 127 V AC in a chassis that is powered by 200 - 240 V AC power supplies, the 100 - 127 V power supply will not power on. The same restriction applies to a chassis that is powered by 100 - 127 V AC power supplies. If you install a 200 - 240 V AC power supply in a chassis that is powered by 100 - 127 V AC power supplies, the 200 - 240 V AC power supply will not power on.

Power supply controls and indicators

There are three LEDs on each power supply:

AC power LED

When this LED is lit (green), it indicates that AC power is being supplied to the power supply.

DC power LED

When this LED is lit (green), it indicates that DC power is being supplied from the power supply to the chassis midplane.

Fault LED

When this LED is lit (yellow), it indicates that there is a fault with the power supply.

Note: Before unplugging the AC power cord from the power supply or removing the power supply from the chassis, verify that the capacity of the remaining power supplies are sufficient to meet the minimum power requirements for all components in the chassis.

Fan modules

The NeXtScale n1200 Enclosure supports ten fan modules.

The fan modules provide cooling to the compute nodes and the fan power control. The following is an illustration of the fan modules:

Fault LED

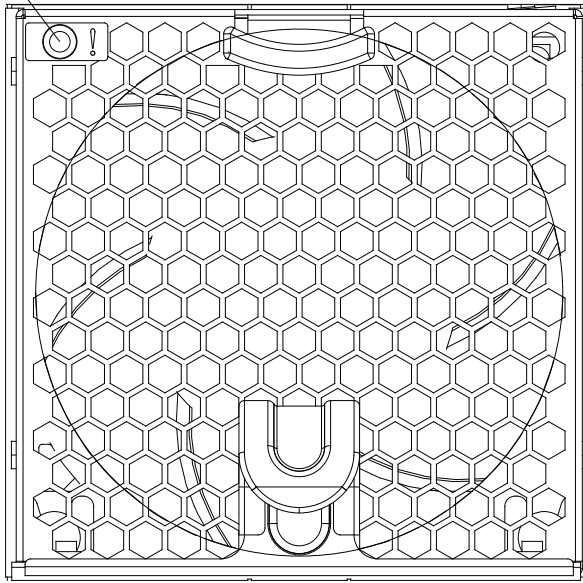

Figure 11. Fan module

Note: All of the fan modules are required to be installed in the NeXtScale n1200 Enclosure.

Fan module controls and indicators

Each fan module has one LED:

Fault LED

When this LED is lit (yellow), it indicates that the fan module has failed.

Chapter 2. Parts listing, NeXtScale n1200 Enclosure Types 5456

The parts listing of NeXtScale n1200 Enclosure Types 5456.

The following replaceable components are available for the NeXtScale n1200 Enclosure Types 5456 server, except as specified otherwise in “[Replaceable server components](#)” on page 17. For an updated parts listing, go to <http://support.lenovo.com>.

Replaceable server components

The replaceable server components for NeXtScale n1200 Enclosure Types 5456.

Replaceable components consist of the following:

- **Structural parts:** Purchase and replacement of structural parts (components, such as chassis assembly, top cover, and bezel) is your responsibility. If Lenovo acquires or installs a structural component at your request, you will be charged for the service. See “[Structural parts](#)” on page 20 for the list of structural parts.
- **Tier 1 customer replaceable unit (CRU):** Replacement of Tier 1 CRUs is your responsibility. If Lenovo installs a Tier 1 CRU at your request, you will be charged for the installation.
- **Tier 2 customer replaceable unit:** You may install a Tier 2 CRU yourself or request Lenovo to install it, at no additional charge, under the type of warranty service that is designated for your server.
- **Field replaceable units (FRUs):** Only Lenovo service technicians are authorized to install or replace FRUs.

For information about the terms of the warranty and getting service and assistance, see the *Warranty Information* document that comes with the server. For more information about getting service and assistance, see [Appendix B “Getting help and technical assistance”](#) on page 123.

Visit the ServerProven website for the latest options supporting plan.

The following illustration shows the major components in the server. The illustrations in this document might differ slightly from your hardware. For a list of structural parts, see “[Structural parts](#)” on page 20.

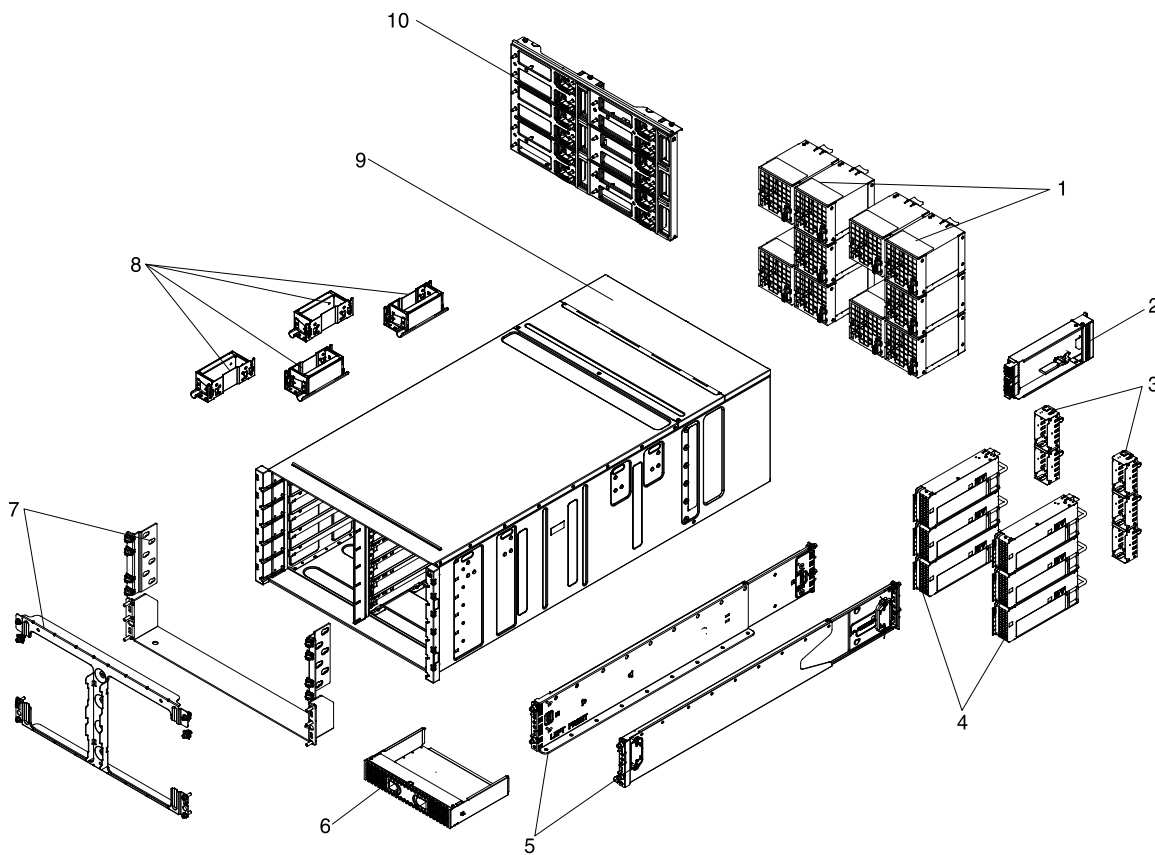

Figure 12. Server components

The following table lists the part numbers for the server replaceable components.

Table 1. Parts listing, Types 5456

Four column table documenting the index number, description of server component, CRU part number (Tier 1), and CRU part number (Tier 2).

| Index | Description | CRU part number (Tier 1) | CRU part number (Tier 2) | FRU part number |
|-------|---------------------------------------|--------------------------|--------------------------|-----------------|
| 1 | System Fans | 00Y7929 | | |
| 2 | Fan power control 2 (Lenovo version) | 01PF064 | | |
| 2 | Fan power control (IBM version) | 00KA860 | | |
| 3 | Power supply filler | 94Y7610 | | |
| 4 | Power supply, 900 watt, AC | 00YJ918 or 00MX927 | | |
| 4 | Power supply, 900 watt, AC | 94Y8314 | | |
| 4 | Power supply, 900 watt, CFF -48V DC | 94Y8167 | | |
| 4 | Power supply, 1300 watt, AC, Platinum | 69Y5925 | | |

Table 1. Parts listing, Types 5456 (continued)

| Index | Description | CRU part number (Tier 1) | CRU part number (Tier 2) | FRU part number |
|-------|---|--------------------------------------|--------------------------|-----------------|
| 4 | Power supply, 1300 watt, AC, Platinum | 94Y8183, 00YJ924, 01PF547 or 00MX932 | | |
| 4 | Power supply, 1300 watt, AC, Titanium | 00Y9107 | | |
| 4 | Power supply, 1300 watt, AC, Titanium | 00YJ947 or 01KP987 | | |
| 4 | Power supply, 1300 watt, AC, Titanium | 94Y8179 | | |
| 4 | Power supply, 1300 watt, AC, Titanium | 00YJ988 | | |
| 4 | Power supply, 1300 watt, AC, Titanium | 94Y8277 | | |
| 4 | Power supply, 1500 watt, Platinum | 94Y8181, 00YJ920, 01PF549 or 00MX929 | | |
| 4 | Power supply, 2000 watt, Platinum | 94Y8207 | | |
| 4 | Power supply, 2000 watt | 00YJ989 or 01KP989 | | |
| 4 | Power supply, 1300 watt, AC, Titanium | 00YJ900, 01PF519 or 00MX911 | | |
| 5 | Rail kit | 88Y6721 | | |
| 10 | Chassis midplane | | | 00YE248 |
| | Fan signal/power cable | | 00AM348 | |
| | Clamp core | 94Y8175 | | |
| | T8 torx screwdriver (provided on the back of the chassis) | 00FK488 | | |
| | Video and USB breakout cable | 81Y2889 | | |
| | Line cord, 10 amp/125-250VAC- 1M (RoHS) | 39M5374 | | |
| | PDU jumper cord | 39M5392 | | |
| | 530 MM/10A cord | 39M5401 | | |
| | Line cord, Y jumper | 39M5450 | | |
| | Y jumper cord | 69Y1627 | | |
| | Hypervisor, embedded USB flash device | 42D0545 | | |
| | Battery, 3.0 volt | 33F8354 | | |
| | Miscellaneous kit | 00AM457 or 02JJ890 | | |

Note: Due to security concern, it is NOT allowed to update FPC (IBM version) to FPC 2 (Lenovo version). With a FPC (IBM version) installed, only do upgrade with IBM firmware or replacement with another unit of IBM FPC. With a FPC 2 (Lenovo version) installed, on the other hand, only do upgrade with Lenovo firmware

or replacement with another unit of Lenovo FPC 2. Note that if IBM FPC is plugged in Lenovo chassis, there will be VPD issue (see <https://support.lenovo.com/solutions/ht501884> for more information).

Structural parts

Structural parts are not covered by the Statement of Limited Warranty. You can place an order on the structural parts from the Lenovo retail store.

The following structural parts are available for purchase from the retail store.

Table 2. Structural parts, Types 5456

Three column structural parts listing table for documenting the index, description, and part number.

| Index | Description | Part number |
|-------|----------------------|-------------|
| 6 | Node filler | 00AM304 |
| 7 | Shipping bracket kit | 00AM303 |
| 8 | Lift handle | 81Y2902 |
| 9 | 6U chassis assembly | 00AM294 |
| | Fan filler | 00AM295 |
| | EIA cover, left | 00AM298 |
| | EIA cover, right | 00AM299 |
| | Shelf left | 00AM301 |
| | Shelf bracket | 00AM302 |
| | Label, GBM | 00AM347 |

To order a structural part, complete the following steps:

Note: Changes are made periodically to the Lenovo website. The actual procedure might vary slightly from what is described in this document.

1. Go to <http://www.lenovo.com>.
2. From the **Products** menu, select **Upgrades, accessories & parts**.
3. Click **Obtain maintenance parts**; then, follow the instructions to order the part from the retail store.

Note: Changes are made periodically to the Lenovo website. The actual procedure might vary slightly from what is described in this document.

If you need help with your order, call the toll-free number that is listed on the retail parts page, or contact your local Lenovo representative for assistance.

Power cords

For your safety, a power cord with a grounded attachment plug is provided to use with this product. To avoid electrical shock, always use the power cord and plug with a properly grounded outlet.

Lenovo power cords used in the United States and Canada are listed by Underwriter's Laboratories (UL) and certified by the Canadian Standards Association (CSA).

For units intended to be operated at 115 volts: Use a UL-listed and CSA-certified cord set consisting of a minimum 18 AWG, Type SVT or SJT, three-conductor cord, a maximum of 15 feet in length and a parallel blade, grounding-type attachment plug rated 15 amperes, 125 volts.

For units intended to be operated at 230 volts (U.S. use): Use a UL-listed and CSA-certified cord set consisting of a minimum 18 AWG, Type SVT or SJT, three-conductor cord, a maximum of 15 feet in length and a tandem blade, grounding-type attachment plug rated 15 amperes, 250 volts.

For units intended to be operated at 230 volts (outside the U.S.): Use a cord set with a grounding-type attachment plug. The cord set should have the appropriate safety approvals for the country in which the equipment will be installed.

Power cords for a specific country or region are usually available only in that country or region.

Two column power cords table for documenting the part number and the specific country or region the power cord is available in.

| Power cord part number | Used in these countries and regions |
|-------------------------------|---|
| 39M5206 | China |
| 39M5102 | Australia, Fiji, Kiribati, Nauru, New Zealand, Papua New Guinea |
| 39M5123 | Afghanistan, Albania, Algeria, Andorra, Angola, Armenia, Austria, Azerbaijan, Belarus, Belgium, Benin, Bosnia and Herzegovina, Bulgaria, Burkina Faso, Burundi, Cambodia, Cameroon, Cape Verde, Central African Republic, Chad, Comoros, Congo (Democratic Republic of), Congo (Republic of), Cote D'Ivoire (Ivory Coast), Croatia (Republic of), Czech Republic, Dahomey, Djibouti, Egypt, Equatorial Guinea, Eritrea, Estonia, Ethiopia, Finland, France, French Guyana, French Polynesia, Germany, Greece, Guadeloupe, Guinea, Guinea Bissau, Hungary, Iceland, Indonesia, Iran, Kazakhstan, Kyrgyzstan, Laos (People's Democratic Republic of), Latvia, Lebanon, Lithuania, Luxembourg, Macedonia (former Yugoslav Republic of), Madagascar, Mali, Martinique, Mauritania, Mauritius, Mayotte, Moldova (Republic of), Monaco, Mongolia, Morocco, Mozambique, Netherlands, New Caledonia, Niger, Norway, Poland, Portugal, Reunion, Romania, Russian Federation, Rwanda, Sao Tome and Principe, Saudi Arabia, Senegal, Serbia, Slovakia, Slovenia (Republic of), Somalia, Spain, Suriname, Sweden, Syrian Arab Republic, Tajikistan, Tahiti, Togo, Tunisia, Turkey, Turkmenistan, Ukraine, Upper Volta, Uzbekistan, Vanuatu, Vietnam, Wallis and Futuna, Yugoslavia (Federal Republic of), Zaire |
| 39M5130 39M5179 | Denmark |
| 39M5144 | Bangladesh, Lesotho, Macao, Maldives, Namibia, Nepal, Pakistan, Samoa, South Africa, Sri Lanka, Swaziland, Uganda |
| 39M5151 | Abu Dhabi, Bahrain, Botswana, Brunei Darussalam, Channel Islands, China (Hong Kong S.A.R.), Cyprus, Dominica, Gambia, Ghana, Grenada, Iraq, Ireland, Jordan, Kenya, Kuwait, Liberia, Malawi, Malaysia, Malta, Myanmar (Burma), Nigeria, Oman, Polynesia, Qatar, Saint Kitts and Nevis, Saint Lucia, Saint Vincent and the Grenadines, Seychelles, Sierra Leone, Singapore, Sudan, Tanzania (United Republic of), Trinidad and Tobago, United Arab Emirates (Dubai), United Kingdom, Yemen, Zambia, Zimbabwe |
| 39M5158 | Liechtenstein, Switzerland |
| 39M5165 | Chile, Italy, Libyan Arab Jamahiriya |
| 39M5172 | Israel |

| Power cord part number | Used in these countries and regions |
|-------------------------------|--|
| 39M5095 | 220 - 240 V Antigua and Barbuda, Aruba, Bahamas, Barbados, Belize, Bermuda, Bolivia, Caicos Islands, Canada, Cayman Islands, Colombia, Costa Rica, Cuba, Dominican Republic, Ecuador, El Salvador, Guam, Guatemala, Haiti, Honduras, Jamaica, Mexico, Micronesia (Federal States of), Netherlands Antilles, Nicaragua, Panama, Peru, Philippines, Saudi Arabia, Thailand, Taiwan, United States of America, Venezuela |
| 39M5081 | 110 - 120 V Antigua and Barbuda, Aruba, Bahamas, Barbados, Belize, Bermuda, Bolivia, Caicos Islands, Canada, Cayman Islands, Colombia, Costa Rica, Cuba, Dominican Republic, Ecuador, El Salvador, Guam, Guatemala, Haiti, Honduras, Jamaica, Mexico, Micronesia (Federal States of), Netherlands Antilles, Nicaragua, Panama, Peru, Philippines, Saudi Arabia, Thailand, Taiwan, United States of America, Venezuela |
| 39M5076 39M5512 | United States of America |
| 39M5463 | Taiwan |
| 39M5087 | Thailand |
| 39M5219 | Korea (Democratic People's Republic of), Korea (Republic of) |
| 39M5199 | Japan |
| 39M5068 | Argentina, Paraguay, Uruguay |
| 39M5226 | India |
| 39M5240 39M5241 | Brazil |
| 39M5375 39M5378 39M5509 | Canada, Germany, United States of America |

Chapter 3. Removing and replacing components

Use this information to remove and replace the chassis components.

The types of replaceable components are:

- **Structural parts:** Purchase and replacement of structural parts (components, such as chassis assembly, top cover, and bezel) is your responsibility. If Lenovo acquires or installs a structural component at your request, you will be charged for the service.
- **Tier 1 customer replaceable unit (CRU):** Replacement of Tier 1 CRUs is your responsibility. If Lenovo installs a Tier 1 CRU at your request, you will be charged for the installation.
- **Tier 2 customer replaceable unit:** You may install a Tier 2 CRU yourself or request Lenovo to install it, at no additional charge, under the type of warranty service that is designated for your server.

See [Chapter 2 “Parts listing, NeXtScale n1200 Enclosure Types 5456” on page 17](#) to determine whether a component is a structural part, Tier 1 CRU, or Tier 2 CRU.

For information about the terms of the warranty, see the *Warranty Information* document that comes with the server.

For more information about getting service and assistance, see [Appendix B “Getting help and technical assistance” on page 123](#).

Installation guidelines

Use the installation guidelines to install the NeXtScale n1200 Enclosure Types 5456.

Attention: Static electricity that is released to internal Compute node components when the Compute node is powered-on might cause the system to halt, which might result in the loss of data. To avoid this potential problem, always use an electrostatic-discharge wrist strap or other grounding system when removing or installing a hot-swap device.

Before you remove or replace a FRU or install an optional device, read the following information:

- Read the safety information in [“Safety” on page iii](#) and the guidelines in *Working inside the server with the power on*, and [“Handling static-sensitive devices” on page 25](#). This information will help you work safely.
- Make sure that the devices that you are installing are supported. For a list of supported optional devices for the chassis, see <http://static.lenovo.com/us/en/serverproven/index.shtml>.
- When you install your new Compute node, take the opportunity to download and apply the most recent firmware updates. This step will help to ensure that any known issues are addressed and that your Compute node is ready to function at maximum levels of performance. To download firmware updates for your Compute node, go to <http://datacentersupport.lenovo.com/products/servers/flex/x240-m5-compute-node/9532/downloads>.

Important: Some cluster solutions require specific code levels or coordinated code updates. If the device is part of a cluster solution, verify that the latest level of code is supported for the cluster solution before you update the code.

For additional information about tools for updating, managing, and deploying firmware, see the ToolsCenter for System x and BladeCenter at <https://support.lenovo.com/us/en/solutions/ht115036>

- Before you install optional hardware, make sure that the compute nodes are working correctly. Start the compute nodes, and make sure that the operating system starts, if an operating system is installed, or that

a 19990305 error code is displayed, indicating that an operating system was not found but the compute node is otherwise working correctly. If the compute node is not working correctly, see Running DSA Preboot diagnostic programs for information about how to run diagnostics.

- Observe good housekeeping in the area where you are working. Place removed covers and other parts in a safe place.
- Do not attempt to lift an object that you think is too heavy for you. If you have to lift a heavy object, observe the following precautions:
 - Make sure that you can stand safely without slipping.
 - Distribute the weight of the object equally between your feet.
 - Use a slow lifting force. Never move suddenly or twist when you lift a heavy object.
 - To avoid straining the muscles in your back, lift by standing or by pushing up with your leg muscles.
- Make sure that you have an adequate number of properly grounded electrical outlets for the server, monitor, and other devices.
- Back up all important data before you make changes to disk drives.
- After the fan power control is installed, back up the chassis midplane VPD data immediately for future data migration in case of the fan power control replacement (see [“System information options” on page 71](#)).
- Have a small flat-blade screwdriver available.
- To view the error LEDs on the system board and internal components, leave the compute node connected to power.
- You do not have to turn off the server to install or replace hot-swap power supplies, hot-swap fans, fan power control, or hot-plug Universal Serial Bus (USB) devices. However, you must turn off the server before you perform any steps that involve removing or installing adapter cables and you must disconnect the power source from the server before you perform any steps that involve removing or installing a riser card.
- Before you remove a compute node from the chassis, you must shut down the operating system and turn off the compute node. You do not have to shut down the chassis itself.
- Blue on a component indicates touch points, where you can grip the component to remove it from or install it in the server, open or close a latch, and so on.
- Orange on a component or an orange label on or near a component indicates that the component can be hot-swapped, which means that if the server and operating system support hot-swap capability, you can remove or install the component while the server is running. (Orange can also indicate touch points on hot-swap components.) See the instructions for removing or installing a specific hot-swap component for any additional procedures that you might have to perform before you remove or install the component.
- When you are finished working on the server, reinstall all safety shields, guards, labels, and ground wires.

System reliability guidelines

The system reliability guidelines to ensure proper system cooling.

To help ensure proper system cooling and system reliability, make sure that the following requirements are met:

- To ensure proper cooling, do not operate the chassis without a compute node or a filler in each node bay.
- You have replaced a compute node within 3 minutes of removal or a filler is installed.
- Make sure that the ventilation holes on the compute node are not blocked.
- The compute node CMOS battery must be operational. If the CMOS battery becomes defective, replace it immediately. See the documentation that comes with the compute node for instructions.

- Replace the fan power control as soon as possible after removal to ensure proper operation of the chassis.

Handling static-sensitive devices

Use this information to handle static-sensitive devices.

Attention: Static electricity can damage the compute node and other electronic devices. To avoid damage, keep static-sensitive devices in their static-protective packages until you are ready to install them.

To reduce the possibility of damage from electrostatic discharge, observe the following precautions:

- When you work on a chassis that has an electrostatic discharge (ESD) connector, use a wrist strap, especially when you handle modules, optional devices, or compute node. To work correctly, the wrist strap must have a good contact at both ends (touching your skin at one end and firmly connected to the ESD connector on the front or back of the chassis).
- Limit your movement. Movement can cause static electricity to build up around you.
- The use of a grounding system is recommended. For example, wear an electrostatic-discharge wrist strap, if one is available. Always use an electrostatic-discharge wrist strap or other grounding system when working inside the server with the power on.
- Handle the device carefully, holding it by its edges or its frame.
- Do not touch solder joints, pins, or exposed circuitry.
- Do not leave the device where others can handle and damage it.
- While the device is still in its static-protective package, touch it to an *unpainted* metal part of the chassis or any *unpainted* metal surface on any other grounded rack component in the rack in which you are installing the device for at least 2 seconds. This drains static electricity from the package and from your body.
- Remove the device from its package and install it directly into the compute node without setting down the device. If it is necessary to set down the device, put it back into its static-protective package. Do not place the device on the compute node cover or on a metal surface.
- Take additional care when handling devices during cold weather. Heating reduces indoor humidity and increases static electricity.

Returning a device or component

If you are instructed to return a device or component, follow all packaging instructions, and use any packaging materials for shipping that are supplied to you.

Removing and replacing structural parts

Replacement of structural parts is your responsibility. If Lenovo installs a structural part at your request, you will be charged for the installation.

The illustrations in this document might differ slightly from your hardware.

Removing the shipping bracket

Use this information to remove the shipping bracket.

To remove the shipping bracket, complete the following steps:

- Step 1. Read the safety information that begins on [“Safety” on page iii](#) and [“Installation guidelines” on page 23](#).

- Step 2. Turn off the compute node and peripheral devices and disconnect the power cords and all external cables.
- Step 3. Remove the rear support brackets:
- Remove the four M5 hex head screws on the lower support bracket and remove the lower support bracket.
 - Slide the chassis away from the rack rails.
 - Remove the three M5 hex head screws on either left or right of the support bracket from the screw holes on the rack.
 - Remove the support bracket from the rack.
 - Repeat steps c and d for another side of the support bracket.

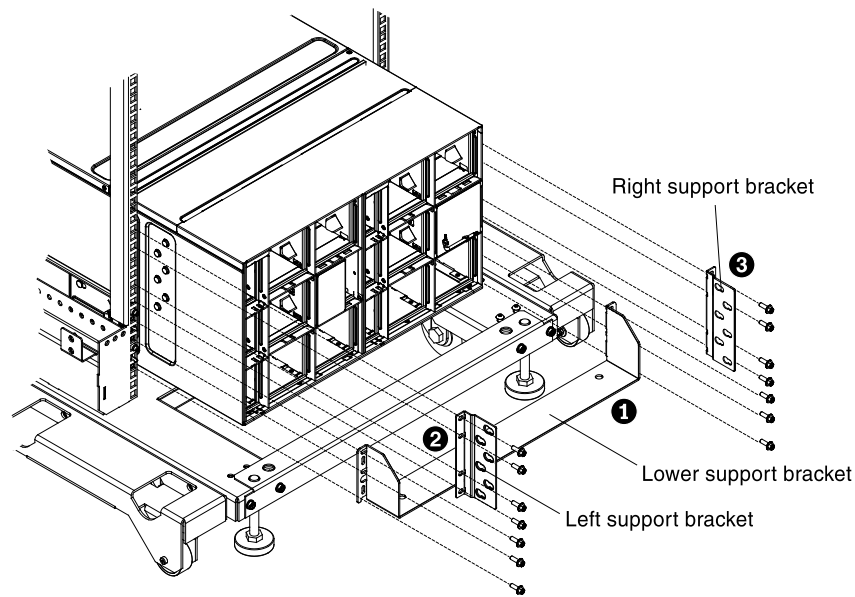

Rear view of shipping bracket assembly

Figure 13. Rear support brackets removal

Replacing the shipping bracket

Use this information to install the shipping bracket.

To install the shipping bracket, complete the following steps:

Note: If you plan to transport the rack to another location, you must install the support brackets that come with the chassis.

- Step 1. Read the safety information that begins on [“Safety” on page iii](#) and [“Installation guidelines” on page 23](#).
- Step 2. Turn off the compute node and peripheral devices and disconnect the power cords and all external cables.
- Step 3. Install the rear support brackets:
- Align the right support bracket with the six slots on the rear of the chassis (outside of the chassis wall).

- b. Slide the support bracket forward until it locks into place in the slots.
- c. Secure the support bracket to the rack with three M5 hex head screws.
- d. Repeat steps a through c for the left support bracket.

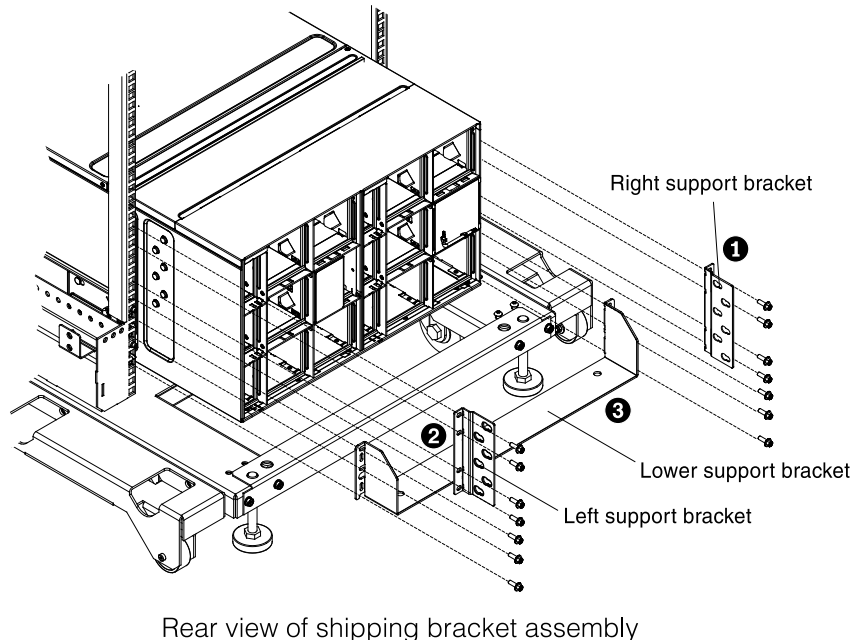

Figure 14. Rear support bracket installation

- e. Fit the lower support bracket to the chassis; then slide it forward against the rack rails and secure the bracket with four M5 hex head screws.

Removing and replacing Tier 1 CRUs

Replacement of Tier 1 CRUs is your responsibility. If Lenovo installs a Tier 1 CRU at your request, you will be charged for the installation.

A working NeXtScale n1200 Enclosure might have numerous power cables, Ethernet cables, and fiber cables that are connected to components on the front and rear of the chassis:

- You might have to disconnect some of the cables when you remove and replace a Tier 1 CRU.
- Make sure that the surrounding cables allow adequate clearance before you remove and replace a Tier 1 CRU.
- Do not pinch, bind, or pull on the cables when you remove and replace a Tier 1 CRU.
- Do not allow unsupported cables to exceed a safe bend radius. For example, a disconnected fiber cable might bend back on itself and become damaged.

The illustrations in this document might differ slightly from your hardware.

Removing a 1-bay compute node

Use these instructions to remove a 1-bay compute node from the NeXtScale n1200 Enclosure.

Attention: To maintain proper system cooling, do not operate the chassis without a compute node or compute node filler in each node bay. Install a compute node or filler within one minute of the removal of a compute node.

Before you remove a 1-bay compute node, complete the following tasks:

1. Make a note of the bay number. Reinstalling a compute node into a different bay from the one from which it was removed can have unintended consequences. Some configuration information and update options are established according to bay number.
2. Shut down the compute node operating system; then, shut down the compute node. See the documentation that comes with your compute node for the procedure to shut down the operating system.

To remove a 1-bay compute node, complete the following steps.

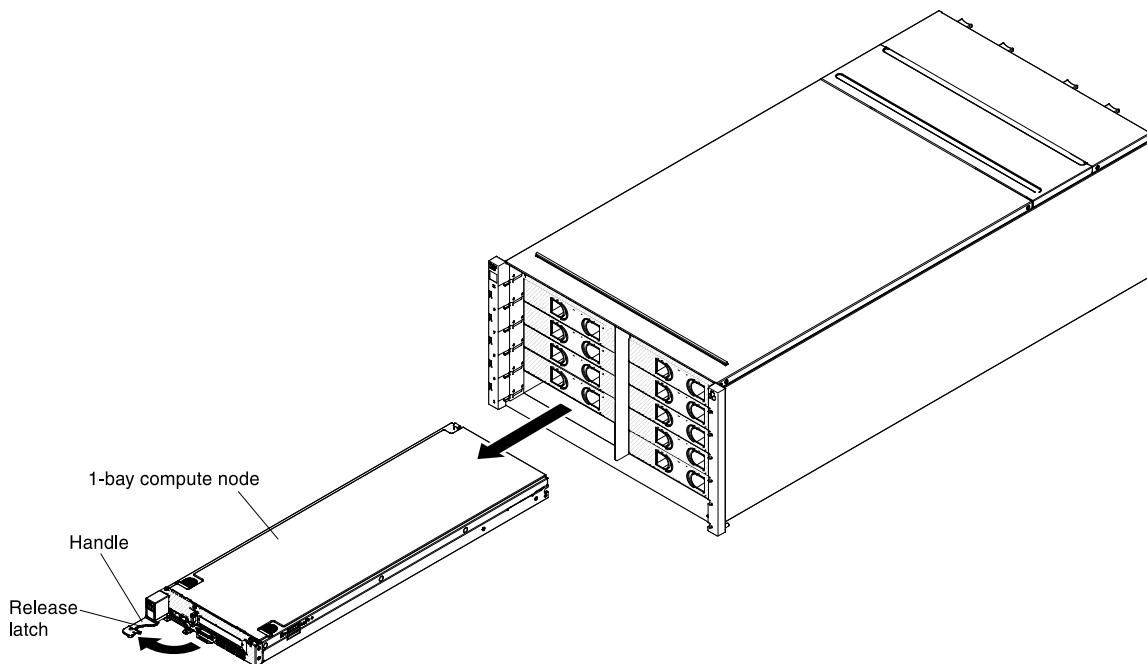

Figure 15. Removal of a 1-bay compute node

- Step 1. Open the release handle (rotate the handle to the left) to disengage the compute node from the chassis.
- Step 2. Use both hands to slide the compute node out of the compute node bay and place it on a flat, static-protective surface.

Replacing a 1-bay compute node

Use these instructions to install a 1-bay compute node in the NeXtScale n1200 Enclosure. You can install a compute node while the chassis is powered on.

Before you install a 1-bay compute node in the chassis, complete the following steps:

1. Read the instructions that come with the compute node.
2. Make sure that you have installed any optional hardware devices in the compute node.

Note: This procedure assumes that you are replacing an existing compute node in the same node bay. If you are installing a new compute node, see Installing components section on chapter 2.

To install a 1-bay compute node, complete the following steps.

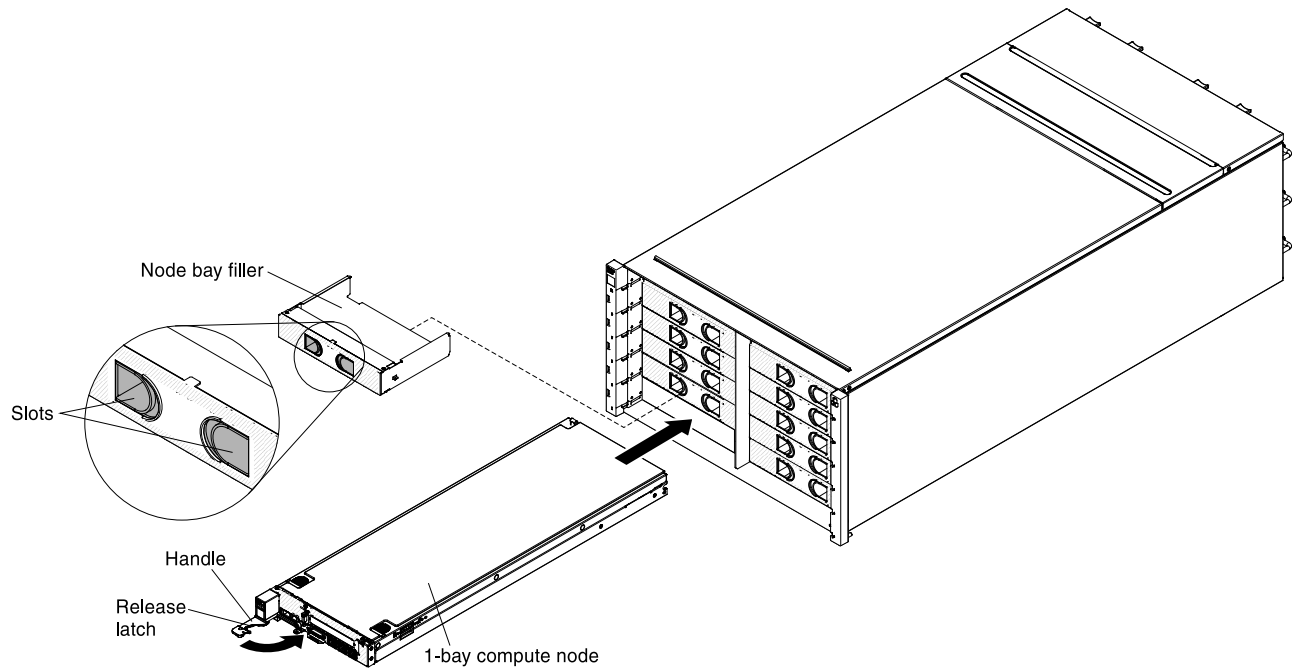

Figure 16. Installation of a 1-bay compute node

- Step 1. Remove the node bay filler, if one is installed. Grasp the filler by the slots and pull it out of the bay.
- Step 2. Open the release handle (rotate the handle to the left).
- Step 3. Slide the compute node into the node bay until it is seated.
- Step 4. Close the release handle (rotate the handle to the right).

After you install the compute node, make a note of the compute node identification information on one of the labels that come with the NeXtScale n1200 Enclosure. Place a label on the node label tab and on the adjacent chassis label plate, to the right or left of the compute node (depending on the bay in which the compute nodes is installed).

Note: If the computer node is pulled out, then you need to put the node filler back into the empty slot.

Important: Do not place the label on the compute node or in any way block the ventilation holes.

Removing a fan module

Use these instructions to remove a fan module from the NeXtScale n1200 Enclosure.

To remove a fan, complete the following steps.

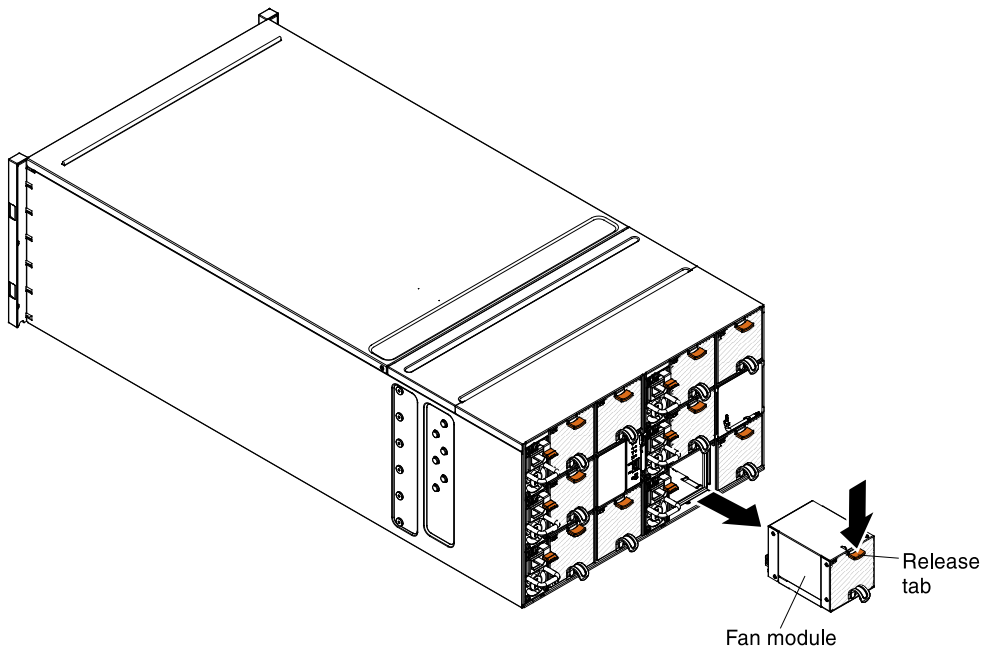

Figure 17. Removal of a fan module

- Step 1. Grasp the fan module handle and press the release tab.
- Step 2. Slide the fan module out of the chassis and place it on a flat, static-protective surface.

Notes:

1. When you remove a fan module from the chassis halfway, release the release tab to avoid the slip of the release tab.
2. When you remove a fan module from the chassis, the remaining fan modules will begin to run at full speed, which will be clearly audible.

Replacing a fan module

Use these instructions to install a fan module in the NeXtScale n1200 Enclosure. You can install a fan module while the NeXtScale n1200 Enclosure is powered on.

To install a fan module, complete the following steps.

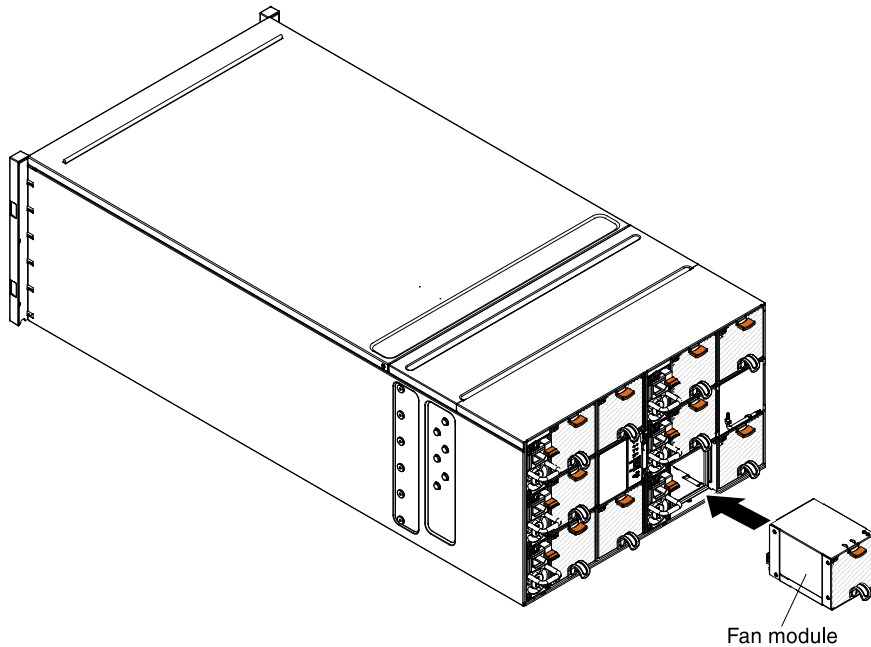

Figure 18. Installation of a fan module

- Step 1. Remove the fan module filler, if one is installed.
- Step 2. Grasp the fan module and align it with the fan bay.
- Step 3. Slide the fan module into the chassis until it locks in place.

Removing the fan power control

Use these instructions to remove the fan power control from the NeXtScale n1200 Enclosure.

1. Disconnect all cables from the fan power control.
2. If you want to migrate current chassis settings and the chassis midplane VPD onto the new fan power control, make sure you have done the following:
 - a. You had performed FPC settings backup, the chassis VPD backup, and the midplane VPD backup procedures (see [“System information options” on page 71](#)).
 - b. Keep the old USB key which is from the fan power control to be removed and install it onto the new fan power control.

To remove an fan power control, complete the following steps.

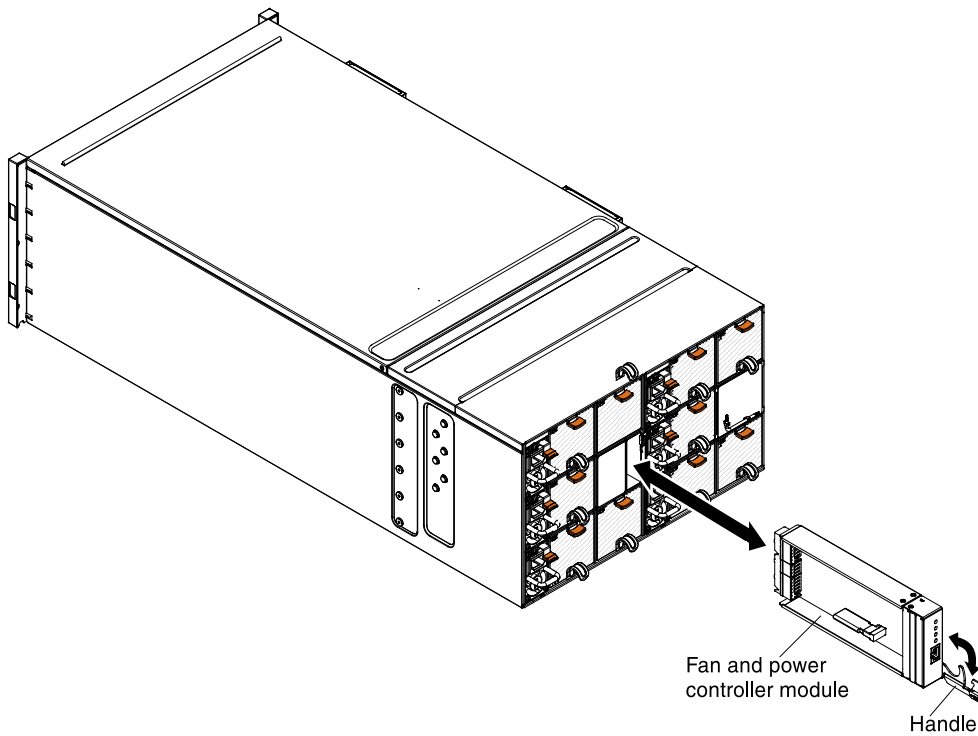

Figure 19. Removal of an fan power control from the chassis

- Step 1. Open the release handle (rotate the handle down) to disengage the fan power control from the chassis.
- Step 2. Slide the module out of the fan power control bay and place it on a flat, static-protective surface.

Replacing an fan power control

Use these instructions to install an fan power control in the NeXtScale n1200 Enclosure. You can install an fan power control while the NeXtScale n1200 Enclosure is powered on.

To install an fan power control, complete the following steps.

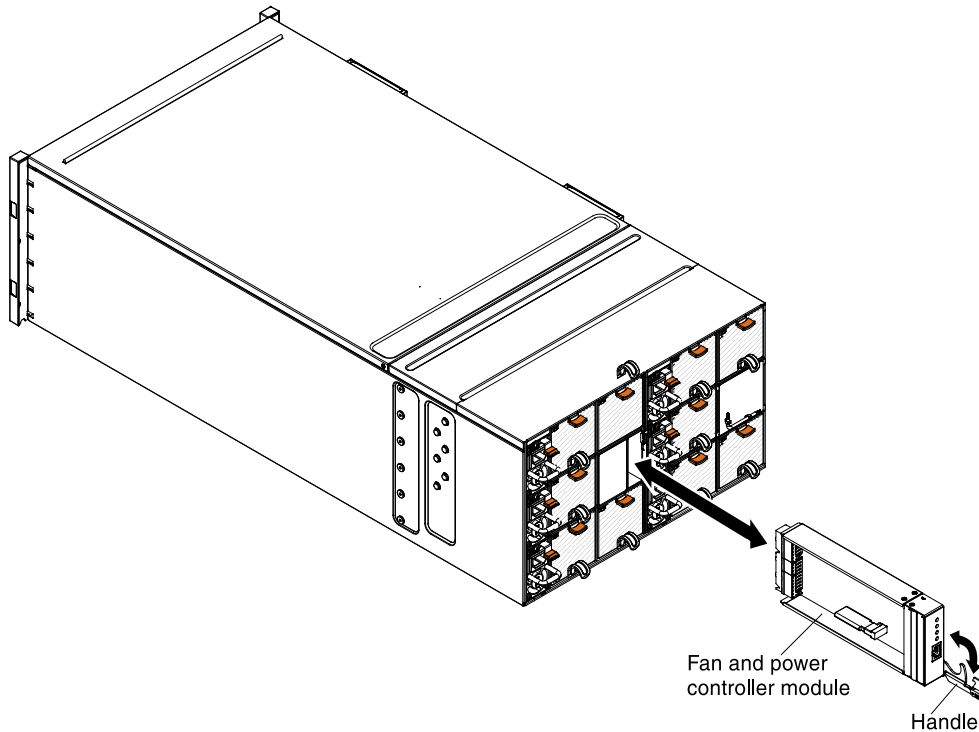

Figure 20. Installation of an fan power control into the chassis

- Step 1. Open the release handle on the fan power control (rotate the handle down).
- Step 2. Align the fan power control with the bay on the chassis and slide the module into the module bay until it is seated.
- Step 3. Close the release handles (rotate the handle up).

After you install the fan power control, complete the following steps.

1. Connect all cables to the module.
2. If you want to restore the old chassis settings and chassis midplane VPD onto the new fan power control after it is replaced, make sure you have followed the restore procedures to restore all of the chassis settings and chassis midplane VPD data from the USB key which is taken from the old fan power control:
 - a. Update the server firmware to the latest level (see [“Configuration options” on page 74](#)).
 - b. Log in to the web interface (see [Chapter 4 “Using the web interface” on page 63](#)).
 - c. Go to **System Information** section, click on the **Midplane VPD** tab.
 - d. For chassis midplane VPD backup, restoring, and updating, see [“System information options” on page 71](#).

Removing the battery from the fan power control

Use this information to remove the CMOS battery from an fan power control.

The following notes describe information that you must consider when replacing the battery.

- Lenovo has designed this product with your safety in mind. The lithium battery must be handled correctly to avoid possible danger. If you replace the battery, you must adhere to the following instructions.

Note: In the U. S., call 1-800-426-4333 for information about battery disposal.

- If you replace the original lithium battery with a heavy-metal battery or a battery with heavy-metal components, be aware of the following environmental consideration. Batteries and accumulators that contain heavy metals must not be disposed of with normal domestic waste. They will be taken back free of charge by the manufacturer, distributor, or representative, to be recycled or disposed of in a proper manner.
- To order replacement batteries, call 1-800-426-SERV within the United States, and 1-800-465-7999 or 1-800-465-6666 within Canada. Outside the U.S. and Canada, call your support center or business partner.

Note: After you replace the battery, you must reconfigure the fan power control time settings.

Statement 2



CAUTION:

When replacing the lithium battery, use only Part Number 33F8354 or an equivalent type battery recommended by the manufacturer. If your system has a module containing a lithium battery, replace it only with the same module type made by the same manufacturer. The battery contains lithium and can explode if not properly used, handled, or disposed of.

Do not:

- Throw or immerse into water
- Heat to more than 100°C (212°F)
- Repair or disassemble

Dispose of the battery as required by local ordinances or regulations.

To remove the battery, complete the following steps:

- Step 1. Read the safety information that begins on [“Safety” on page iii](#) and [“Installation guidelines” on page 23](#).
- Step 2. If the fan power control is installed in the NeXtScale n1200 Enclosure, remove it (see [“Removing the fan power control” on page 31](#)).
- Step 3. Carefully lay the fan power control on a flat, static-protective surface.
- Step 4. Locate the battery.

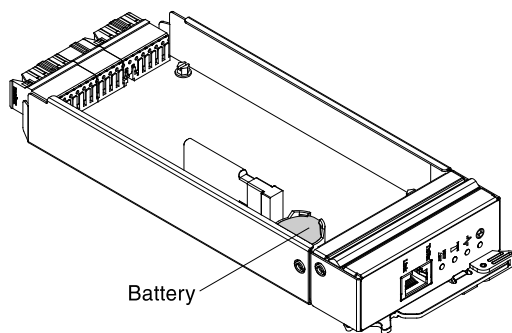

Figure 21. Locate the battery

- Step 5. Using your fingernail, press the battery retaining clip. The battery should pop free.

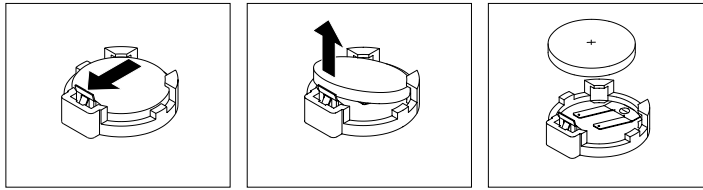

Figure 22. Battery removal

Attention: Do not lift the battery by using excessive force. Failing to remove the battery properly may damage the socket on the fan power control. Any damage to the socket may require replacing the fan power control.

Step 6. Lift the battery from the socket.

Step 7. Dispose of the battery as required by local ordinances or regulations. See the *Environmental Notices and User's Guide* on the *Documentation CD* for more information.

Replacing the battery in the fan power control

The following notes describe information that you must consider when replacing the battery in the fan power control.

- When replacing the battery, you must replace it with a lithium battery of the same type from the same manufacturer.
- To order replacement batteries, call 1-800-426-7378 within the United States, and 1-800-465-7999 or 1-800-465-6666 within Canada. Outside the U.S. and Canada, call your Lenovo marketing representative or authorized reseller.
- After you replace the battery, you must reconfigure the fan power control time settings.
- To avoid possible danger, read and follow the following safety statement.

Statement 2



CAUTION:

When replacing the lithium battery, use only Part Number 33F8354 or an equivalent type battery recommended by the manufacturer. If your system has a module containing a lithium battery, replace it only with the same module type made by the same manufacturer. The battery contains lithium and can explode if not properly used, handled, or disposed of.

Do not:

- **Throw or immerse into water**
- **Heat to more than 100°C (212°F)**
- **Repair or disassemble**

Dispose of the battery as required by local ordinances or regulations.

To install the replacement battery, complete the following steps:

Step 1. Read the safety information that begins on [“Safety” on page iii](#) and [“Installation guidelines” on page 23](#).

- Step 2. If the fan power control is installed in the NeXtScale n1200 Enclosure, remove it (see [“Removing the fan power control” on page 31](#)).
- Step 3. Make sure that the fan power control is on a flat, static-protective surface, with the release handle side up and the bezel pointing toward you.
- Step 4. Locate the battery.

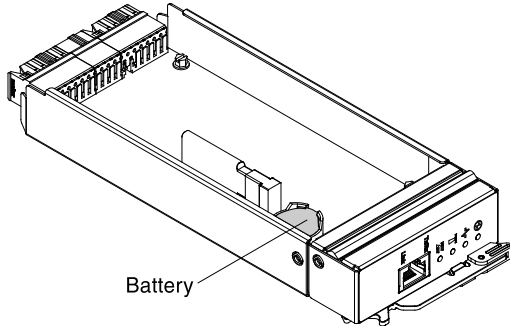

Figure 23. Locate the battery

- Step 5. If a battery is already installed, remove it:
 - a. Using your fingernail, press the battery retaining clip. The battery should pop free.

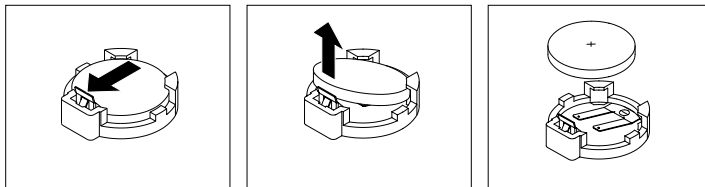

Figure 24. Battery removal

Attention: Do not lift the battery by using excessive force. Failing to remove the battery properly may damage the socket on the fan power control. Any damage to the socket may require replacing the fan power control.

- b. Lift the battery from the socket.

- Step 6. Follow any special handling and installation instructions that come with the replacement battery.
- Step 7. Tilt the battery so that you can insert it into the socket.

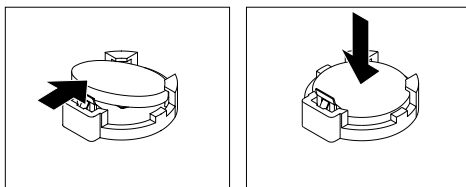

Figure 25. Battery installation

- Step 8. As you slide the battery into place, press the battery down into the socket until it clicks into place.
- Step 9. Install the fan power control into the chassis (see [“Replacing an fan power control” on page 32](#)).
- Step 10. Start the Setup utility and reset the configuration.

Removing the USB flash drive

Use this information to remove the USB flash drive.

Before you remove the USB flash drive, complete the following steps:

Note: A USB flash drive must be installed for fan power control to maintain chassis settings after AC cycle.

1. Read [“Safety” on page iii](#) and [“Installation guidelines” on page 23](#).
2. If the fan power control is installed in the NeXtScale n1200 Enclosure, remove it (see [“Removing the fan power control” on page 31](#)).
3. Carefully lay the compute node on a flat, static-protective surface, orienting the compute node with the bezel pointing toward you.

To remove the USB flash drive, complete the following steps.

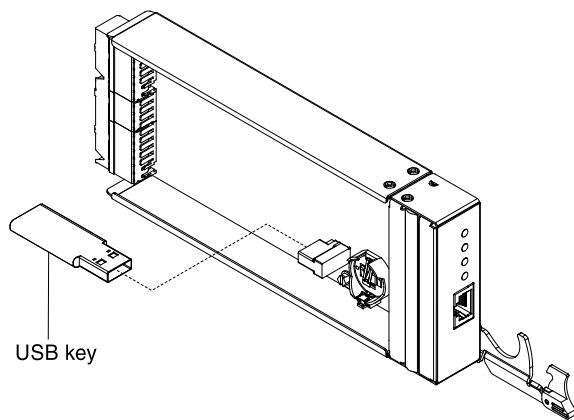

Figure 26. USB flash drive removal

- Step 1. Locate the USB connector on the fan power control.
- Step 2. Pull the USB flash drive out of the connector.

If you are instructed to return the USB flash drive, follow all packaging instructions, and use any packaging materials for shipping that are supplied to you.

Note: If data is not or unable to be migrated from the old USB flash drive onto the new USB flash drive, you must reconfigure the fan power control settings.

Installing the USB flash drive

Use this information to install the USB flash drive.

Before you install the USB flash drive, complete the following steps:

1. Read [“Safety” on page iii](#) and [“Installation guidelines” on page 23](#).
2. If the fan power control is installed in the NeXtScale n1200 Enclosure, remove it (see [“Removing the fan power control” on page 31](#)).
3. Carefully lay the compute node on a flat, static-protective surface, orienting the compute node with the bezel pointing toward you.

This component can be installed as an optional device or as a CRU. The installation procedure is the same for the optional device and the CRU.

To install the USB flash drive, complete the following steps.

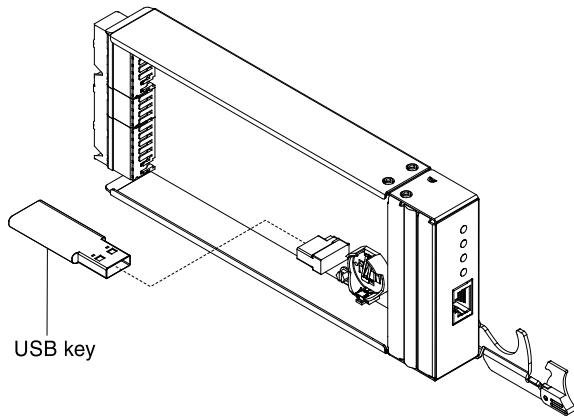

Figure 27. Installing USB flash drive

Step 1. Locate the USB connector on the fan power control.

Step 2. Push the USB flash drive into the connector.

After you install the USB flash drive, install the fan power control into the chassis (see [“Replacing an fan power control”](#) on page 32).

Removing a hot-swap DC power supply

Use this information to remove a hot-swap DC power supply.

When you remove or install a hot-swap DC power supply, observe the following precautions.

Statement 29



CAUTION: This equipment is designed to permit the connection of the earthed conductor of the DC supply circuit to the earthing conductor at the equipment.

This equipment is designed to permit the connection of the earthed conductor of the DC supply circuit to the earthing conductor at the equipment. If this connection is made, all of the following conditions must be met:

- This equipment shall be connected directly to the DC supply system earthing electrode conductor or to a bonding jumper from an earthing terminal bar or bus to which the DC supply system earthing electrode conductor is connected.
- This equipment shall be located in the same immediate area (such as, adjacent cabinets) as any other equipment that has a connection between the earthed conductor of the same DC supply circuit and the earthing conductor, and also the point of earthing of the DC system. The DC system shall not be earthed elsewhere.
- The DC supply source shall be located within the same premises as this equipment.
- Switching or disconnecting devices shall not be in the earthed circuit conductor between the DC source and the point of connection of the earthing electrode conductor.

Statement 31



 **DANGER**

Electrical current from power, telephone, and communication cables is hazardous.

To avoid a shock hazard:

- **Do not connect or disconnect any cables or perform installation, maintenance, or reconfiguration of this product during an electrical storm.**
- **Connect all power cords to a properly wired and grounded power source.**
- **Connect to properly wired power sources any equipment that will be attached to this product.**
- **When possible, use one hand only to connect or disconnect signal cables.**
- **Never turn on any equipment when there is evidence of fire, water, or structural damage.**
- **Disconnect the attached ac power cords, dc power sources, network connections, telecommunications systems, and serial cables before you open the device covers, unless you are instructed otherwise in the installation and configuration procedures.**
- **Connect and disconnect cables as described in the following table when you install, move, or open covers on this product or attached devices.**

To Connect:

1. Turn OFF all power sources and equipment that is to be attached to this product.
2. Attach signal cables to the product.
3. Attach power cords to the product.
 - For ac systems, use appliance inlets.
 - For dc systems, ensure correct polarity of -48 V dc connections: RTN is + and -48 V dc is -. Earth ground should use a two-hole lug for safety.
4. Attach signal cables to other devices.
5. Connect power cords to their sources.
6. Turn ON all the power sources.

To Disconnect:

1. Turn OFF all power sources and equipment that is to be attached to this product.
 - For ac systems, remove all power cords from the chassis power receptacles or interrupt power at the ac power distribution unit.
 - For dc systems, disconnect dc power sources at the breaker panel or by turning off the power source. Then, remove the dc cables.
2. Remove the signal cables from the connectors.
3. Remove all cables from the devices.

Statement 33



CAUTION:

This product does not provide a power-control button. Turning off blades or removing power modules and I/O modules does not turn off electrical current to the product. The product also might have more than one power cord. To remove all electrical current from the product, make sure that all power cords are disconnected from the power source.

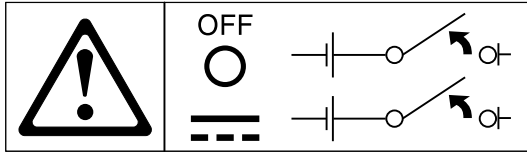

Statement 34



CAUTION:

To reduce the risk of electric shock or energy hazards:

- This equipment must be installed by trained service personnel in a restricted-access location, as defined by the NEC and IEC 60950-1, First Edition, The Standard for Safety of Information Technology Equipment.
- Connect the equipment to a properly grounded safety extra low voltage (SELV) source. A SELV source is a secondary circuit that is designed so that normal and single fault conditions do not cause the voltages to exceed a safe level (60 V direct current).
- Incorporate a readily available approved and rated disconnect device in the field wiring.
- See the specifications in the product documentation for the required circuit-breaker rating for branch circuit overcurrent protection.
- Use copper wire conductors only. See the specifications in the product documentation for the required wire size.
- See the specifications in the product documentation for the required torque values for the wiring-terminal screws.

To remove a hot-swap DC power supply, complete the following steps:

- Step 1. Read the safety information that begins on [“Safety” on page iii](#) and [“Installation guidelines” on page 23](#).
- Step 2. If only one power supply is installed, turn off the server and peripheral devices and disconnect all power cords.
- Step 3. Press and hold the release tab to the left. Grasp the handle and pull the power supply out of the server.

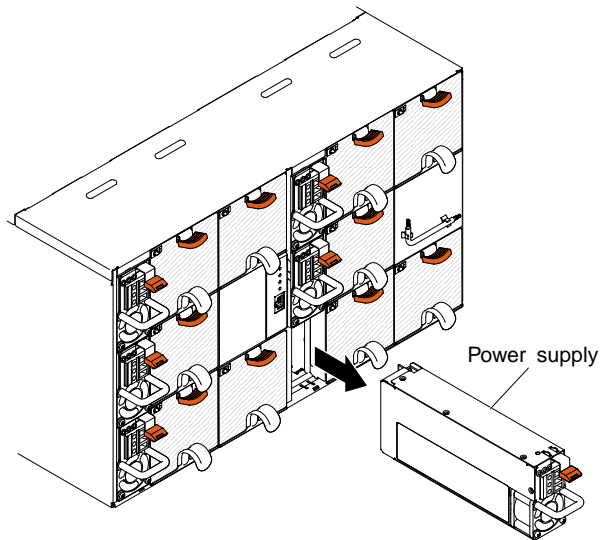

Figure 28. Power supply removal

If you are instructed to return the power supply, follow all packaging instructions, and use any packaging materials for shipping that are supplied to you.

Replacing a hot-swap DC power supply

To install a hot-swap DC power supply, complete the following steps.

- Only trained service personnel other than Lenovo service technicians are authorized to install and remove the -48 volt DC power supply, and make the connections to and disconnections from the -48 volt DC power source. Lenovo service technicians are not certified or authorized to install or remove the -48 volt power cable. The customer is responsible for ensuring that only trained service personnel install or remove the -48 volt power cable.
- Before you install a DC power supply in the server, you must remove all AC power supplies. Do not use both AC and DC power supplies in the same server. Install six DC power supplies or six AC power supplies, but not a combination.
- If you need to order more ferrite clamp cores, the part number is 94Y8175.

Regulations

- It is the customer's responsibility to supply the necessary power cable. **To reduce the risk of electric shock or energy hazards:**

- Use a circuit breaker that is rated at 70 amps.
- Use 4 mm² (10 AWG) at 90° C copper wire.
- Torque the wiring-terminal screws to 0.50 ~ 0.60 newton-meters (4.43 ~ 5.31 inch-pounds).

For more information, see Statement 34.

- If the power source requires ring terminals, you must use a crimping tool to install the ring terminals to the power cord wires. The ring terminals must be UL approved and must accommodate the wire that is described in the above-mentioned note.
- To avoid radiated emission, you must attach a clamp core for each of the 900 W DC power supply used.

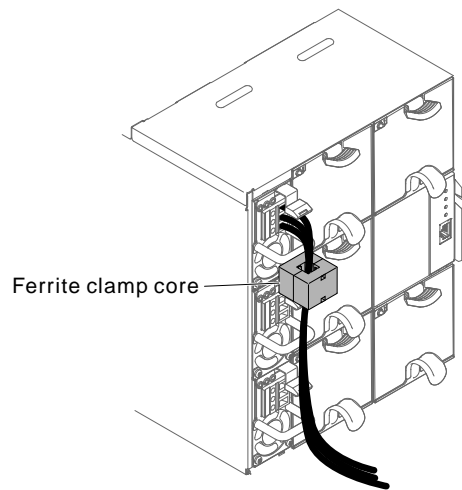

Figure 29. Ferrite clamp core

Statement 29



CAUTION: This equipment is designed to permit the connection of the earthed conductor of the DC supply circuit to the earthing conductor at the equipment.

This equipment is designed to permit the connection of the earthed conductor of the DC supply circuit to the earthing conductor at the equipment. If this connection is made, all of the following conditions must be met:

- This equipment shall be connected directly to the DC supply system earthing electrode conductor or to a bonding jumper from an earthing terminal bar or bus to which the DC supply system earthing electrode conductor is connected.
- This equipment shall be located in the same immediate area (such as, adjacent cabinets) as any other equipment that has a connection between the earthed conductor of the same DC supply circuit and the earthing conductor, and also the point of earthing of the DC system. The DC system shall not be earthed elsewhere.
- The DC supply source shall be located within the same premises as this equipment.
- Switching or disconnecting devices shall not be in the earthed circuit conductor between the DC source and the point of connection of the earthing electrode conductor.

Statement 31



 **DANGER**

Electrical current from power, telephone, and communication cables is hazardous.

To avoid a shock hazard:

- **Do not connect or disconnect any cables or perform installation, maintenance, or reconfiguration of this product during an electrical storm.**
- **Connect all power cords to a properly wired and grounded power source.**
- **Connect to properly wired power sources any equipment that will be attached to this product.**
- **When possible, use one hand only to connect or disconnect signal cables.**
- **Never turn on any equipment when there is evidence of fire, water, or structural damage.**
- **Disconnect the attached ac power cords, dc power sources, network connections, telecommunications systems, and serial cables before you open the device covers, unless you are instructed otherwise in the installation and configuration procedures.**
- **Connect and disconnect cables as described in the following table when you install, move, or open covers on this product or attached devices.**

To Connect:

1. Turn OFF all power sources and equipment that is to be attached to this product.
2. Attach signal cables to the product.
3. Attach power cords to the product.
 - For ac systems, use appliance inlets.
 - For dc systems, ensure correct polarity of -48 V dc connections: RTN is + and -48 V dc is -. Earth ground should use a two-hole lug for safety.
4. Attach signal cables to other devices.
5. Connect power cords to their sources.
6. Turn ON all the power sources.

To Disconnect:

1. Turn OFF all power sources and equipment that is to be attached to this product.
 - For ac systems, remove all power cords from the chassis power receptacles or interrupt power at the ac power distribution unit.
 - For dc systems, disconnect dc power sources at the breaker panel or by turning off the power source. Then, remove the dc cables.
2. Remove the signal cables from the connectors.
3. Remove all cables from the devices.

Statement 33



CAUTION:

This product does not provide a power-control button. Turning off blades or removing power modules and I/O modules does not turn off electrical current to the product. The product also might have more than one power cord. To remove all electrical current from the product, make sure that all power cords are disconnected from the power source.

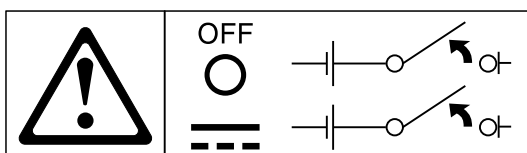

Statement 34



CAUTION:

To reduce the risk of electric shock or energy hazards:

- This equipment must be installed by trained service personnel in a restricted-access location, as defined by the NEC and IEC 60950-1, First Edition, The Standard for Safety of Information Technology Equipment.
- Connect the equipment to a properly grounded safety extra low voltage (SELV) source. A SELV source is a secondary circuit that is designed so that normal and single fault conditions do not cause the voltages to exceed a safe level (60 V direct current).
- Incorporate a readily available approved and rated disconnect device in the field wiring.
- See the specifications in the product documentation for the required circuit-breaker rating for branch circuit overcurrent protection.
- Use copper wire conductors only. See the specifications in the product documentation for the required wire size.
- See the specifications in the product documentation for the required torque values for the wiring-terminal screws.

- Step 1. Read the safety information that begins on [“Safety” on page iii](#) and [“Installation guidelines” on page 23](#).
- Step 2. Touch the static-protective package that contains the hot-swap power supply to any unpainted metal surface on the server; then, remove the power supply from the package and place it on a static-protective surface.
- Step 3. Turn off the circuit breaker for the DC power source to which the new power supply will be connected. Disconnect the power cord from the DC power source.
- Step 4. Attach the DC power cable to the new power supply.

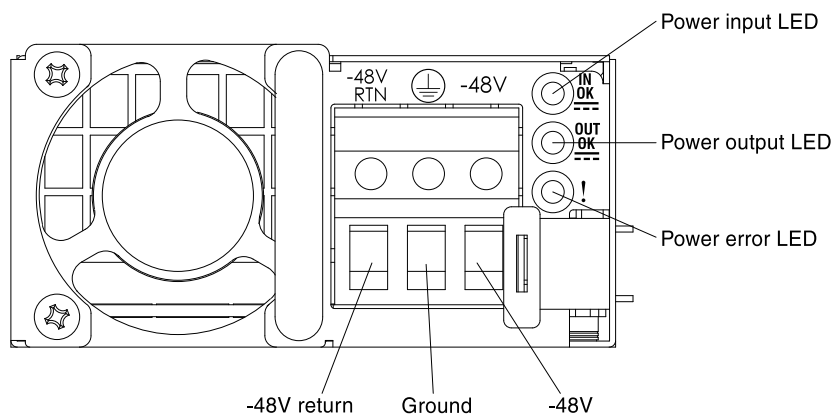

Figure 30. DC power supply rear view

- Step 5. If you are installing a hot-swap power supply into an empty bay, remove the power-supply filler from the power-supply bay.

- Step 6. Grasp the handle on the rear of the power supply and slide the power supply forward into the power-supply bay until it clicks. Make sure that the power supply connects firmly into the power-supply connector.

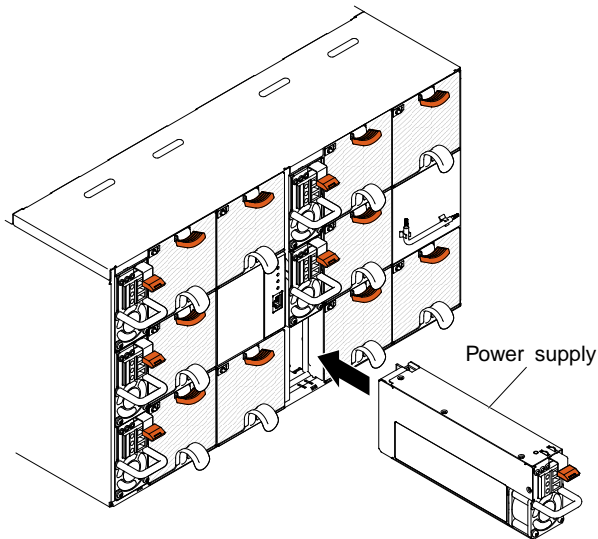

Figure 31. Power supply installation

- Step 7. Route the power cord through the handle and cable tie if any, so that it does not accidentally become unplugged.
- Step 8. Connect the other ends of the DC power cable to the DC power source. Cut the wires to the correct length, but do not cut them shorter than 150 mm (6 inch). If the power source requires ring terminals, you must use a crimping tool to install the ring terminals to the power cord wires. The ring terminals must be UL approved and must accommodate the wires that are described in **Regulations**. The minimum nominal thread diameter of a pillar or stud type of terminal must be 4 mm; for a screw type of terminal the diameter must be 5.0 mm.
- Step 9. Attach the ferrite clamp core nearby to power supply with all input cables including the -48V, the -48V RTN, and the ground cable.
- Step 10. Turn on the circuit breaker for the DC power source to which the new power supply is connected.
- Step 11. Make sure that the green power LEDs on the power supply are lit, indicating that the power supply is operating correctly.
- Step 12. If you are adding a power supply to the server, attach the redundant power information label that comes with this option on the server cover near the power supplies.

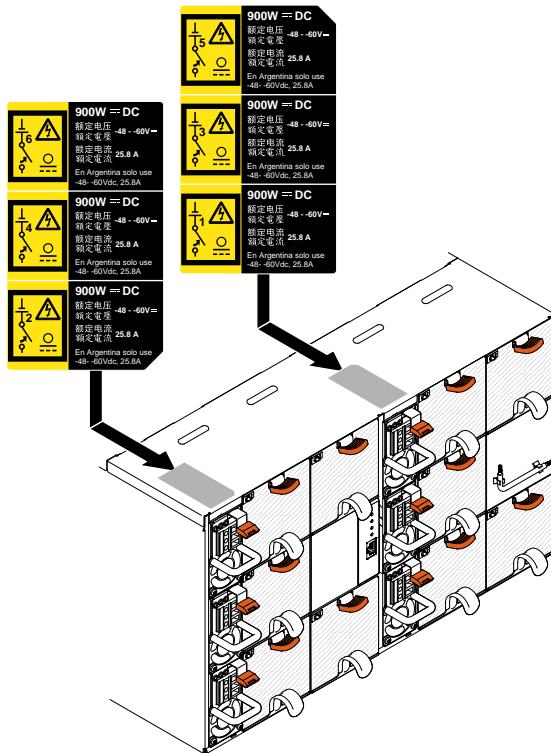

Figure 32. Redundant power information label

Removing an AC power supply

Use these instructions to remove an AC power supply from the NeXtScale n1200 Enclosure.

Attention:

- To maintain proper system cooling, do not operate the NeXtScale n1200 Enclosure without an AC power supply in each power supply bay. Install an AC power supply within 1 minute of the removal of a power supply.
- If you are removing a functioning power supply, make sure that power LEDs on the remaining power supplies are lit and the power redundant policy that you have chosen supports the removal of the AC power supply. If the power management policy does not support removal of an AC power supply, shut down the operating systems and turn off all of the compute nodes before you proceed. (See the documentation that comes with the compute node for instructions for shutting down the compute node operating system and turning off the compute node.)

To remove an AC power supply, complete the following steps.

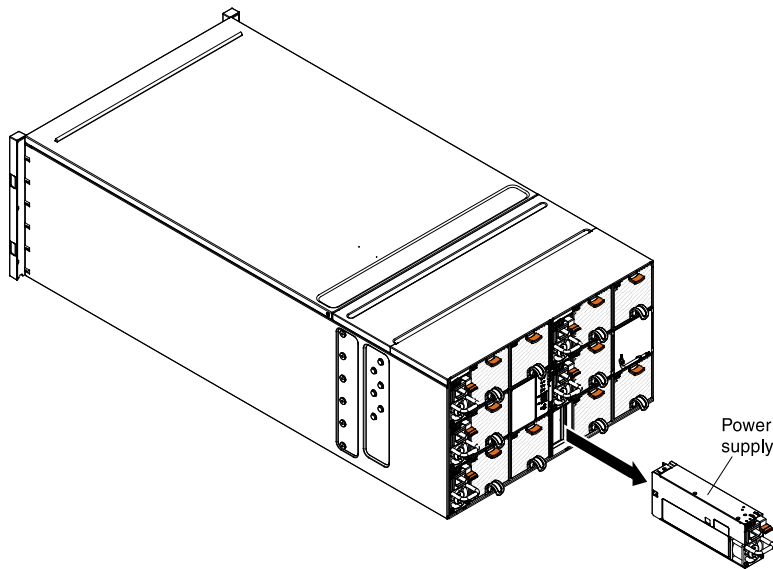

Figure 33. Removal of an AC power supply

- Step 1. Disconnect the power cord from the power supply.
- Step 2. Grasp the handle and press the release tab down.
- Step 3. Slide the AC power supply out of the power-supply bay and place it on a flat, static-protective surface.

If you are instructed to return the AC power supply, follow all packaging instructions, and use any packaging materials for shipping that are supplied to you.

Replacing an AC power supply

Use these instructions to install an AC power supply in the NeXtScale n1200 Enclosure. You can install an AC power supply while the NeXtScale n1200 Enclosure is powered on.

Important:

- Use only power supplies of the same power rating or wattage in each chassis.
- Make sure the input power is phase-to-phase, or, phase-to-neutral, 100 to 127 volt AC nominal, 50/60 Hz for low-line; or 200 to 240 volt AC nominal, 50/60 Hz for high-line power supplies.
- For 900-watt power supplies, if operating at low-line V_{in} (AC 100V - 127V), the power output can only be up to 600-watt. Up to 900-watt if operating at high-line V_{in} (AC 200V - 240V).
- You can only use 1300-watt power supplies with high-line V_{in} (AC 200V - 240V).
- Make sure that the power cord is not connected to the power supply when you install the power supply in the chassis.
- Do not remove the velcro strap from the rear of the power supply.

The following tables provide an indication of the quantity of nodes that can be installed in a chassis for specific processor types assuming nodes have all DIMM slots, PCIe slots, and hard disk drives populated. The tables are based on 900-watt or 1300-watt power supplies and the indicated power settings. However, when building a NeXtScale n1200 Enclosure solution, you are required to validate the power requirements for your configuration using the latest version of the Power Configurator to ensure that the number of power supplies selected are adequate for supporting your chassis configuration. Failure to validate the configuration with the Power Configurator tool could result in system errors, failure to power on, or microprocessor throttling, and limiting system's ability to leverage all of the microprocessor performance.

The Power Configurator tool can be found at <https://pcsupport.lenovo.com/us/en/downloads/ds112002>. If there are questions or issues regarding a configuration and Power Configurator, please send them to power@us.ibm.com.

Table 3. Compute nodes supported (high-line AC input, with 900-watt power supply x6)

Six column table documenting the microprocessor SKU, # of microprocessor(s), non-redundant or N+1 with OVS, N=5, N+1 redundant, N=5, N+N redundant, N=3, and N+N redundant with OVS, N=3.

| Microprocessor SKU (W) | # of micro-processor(s) | Non-redundant or N+1 with OVS ¹ , N=5 | N+1 redundant, N=5 | N+N redundant, N=3 | N+N redundant with OVS ¹ , N=3 |
|------------------------|-------------------------|--|--------------------|--------------------|---|
| 50 | 1 | 12 | 12 | 12 | 12 |
| | 2 | 12 | 12 | 11 | 12 |
| 60 | 1 | 12 | 12 | 12 | 12 |
| | 2 | 12 | 12 | 10 | 12 |
| 70 | 1 | 12 | 12 | 12 | 12 |
| | 2 | 12 | 12 | 8 | 11 |
| 80 | 1 | 12 | 12 | 11 | 12 |
| | 2 | 12 | 12 | 8 | 9 |
| 95 | 1 | 12 | 12 | 10 | 12 |
| | 2 | 12 | 12 | 6 | 10 |
| 115 | 1 | 12 | 12 | 8 | 10 |
| | 2 | 12 | 10 | 5 | 8 |
| 130 | 1 | 12 | 12 | 7 | 9 |
| | 2 | 10 | 8 | 4 | 7 |

Note: 1. OVS (Oversubscription) of the power system allows for more efficient use of the available system power.

Table 4. Compute nodes supported (low-line AC input, with 900-watt power supply x6)

Six column table documenting the microprocessor SKU, # of microprocessor(s), non-redundant or N+1 with OVS, N=5, N+1 redundant, N=5, N+N redundant, N=3, and N+N redundant with OVS, N=3.

| Microprocessor SKU (W) | # of micro-processor(s) | Non-redundant or N+1 with OVS ¹ , N=5 | N+1 redundant, N=5 | N+N redundant, N=3 | N+N redundant with OVS ¹ , N=3 |
|------------------------|-------------------------|--|--------------------|--------------------|---|
| 50 | 1 | 12 | 12 | 9 | 11 |
| | 2 | 12 | 12 | 6 | 10 |
| 60 | 1 | 12 | 12 | 7 | 9 |
| | 2 | 12 | 9 | 5 | 7 |

Table 4. Compute nodes supported (low-line AC input, with 900-watt power supply x6) (continued)

| Microprocessor SKU (W) | # of micro-processor(s) | Non-redundant or N+1 with OVS ¹ , N=5 | N+1 redundant, N=5 | N+N redundant, N=3 | N+N redundant with OVS ¹ , N=3 |
|------------------------|-------------------------|--|--------------------|--------------------|---|
| 70 | 1 | 12 | 12 | 7 | 9 |
| | 2 | 12 | 9 | 5 | 7 |
| 80 | 1 | 12 | 12 | 6 | 8 |
| | 2 | 10 | 9 | 5 | 7 |
| 95 | 1 | 12 | 11 | 6 | 7 |
| | 2 | 9 | 7 | 4 | 6 |
| 115 | 1 | 11 | 9 | 5 | 6 |
| | 2 | 7 | 6 | 3 | 5 |
| 130 | 1 | 9 | 8 | 4 | 5 |
| | 2 | 6 | 5 | 3 | 4 |

Note: 1. OVS (Oversubscription) of the power system allows for more efficient use of the available system power.

Table 5. Compute nodes supported (high-line AC input, with 1300-watt power supply x6)

Six column table documenting the microprocessor SKU, # of microprocessor(s), non-redundant or N+1 with OVS, N=5, N+1 redundant, N=5, N+N redundant, N=3, and N+N redundant with OVS, N=3.

| Microprocessor SKU (W) | # of micro-processor(s) | Non-redundant or N+1 with OVS ¹ , N=5 | N+1 redundant, N=5 | N+N redundant, N=3 | N+N redundant with OVS ¹ , N=3 |
|------------------------|-------------------------|--|--------------------|--------------------|---|
| 50 | 1 | 12 | 12 | 12 | 12 |
| | 2 | 12 | 12 | 12 | 12 |
| 60 | 1 | 12 | 12 | 12 | 12 |
| | 2 | 12 | 12 | 12 | 12 |
| 70 | 1 | 12 | 12 | 12 | 12 |
| | 2 | 12 | 12 | 12 | 12 |
| 80 | 1 | 12 | 12 | 12 | 12 |
| | 2 | 12 | 12 | 12 | 12 |
| 95 | 1 | 12 | 12 | 12 | 12 |
| | 2 | 12 | 12 | 10 | 12 |
| 115 | 1 | 12 | 12 | 12 | 12 |
| | 2 | 12 | 12 | 8 | 12 |
| 130 | 1 | 12 | 12 | 12 | 12 |

Table 5. Compute nodes supported (high-line AC input, with 1300-watt power supply x6) (continued)

| Microprocessor SKU (W) | # of micro-processor(s) | Non-redundant or N+1 with OVS ¹ , N=5 | N+1 redundant, N=5 | N+N redundant, N=3 | N+N redundant with OVS ¹ , N=3 |
|------------------------|-------------------------|--|--------------------|--------------------|---|
| | 2 | 12 | 12 | 7 | 11 |

Note: 1. OVS (Oversubscription) of the power system allows for more efficient use of the available system power.

Table 6. Compute nodes + two 130-watt² GPUs supported (high-line AC input, with 1300-watt power supply x6)

Six column table documenting the microprocessor SKU, # of microprocessor(s), non-redundant or N+1 with OVS, N=5, N+1 redundant, N=5, N+N redundant, N=3, and N+N redundant with OVS, N=3.

| Microprocessor SKU (W) | # of micro-processor(s) | Non-redundant or N+1 with OVS ¹ , N=5 | N+1 redundant, N=5 | N+N redundant, N=3 | N+N redundant with OVS ¹ , N=3 |
|------------------------|-------------------------|--|--------------------|---------------------------|---|
| 50 | 1 | 6 | 6 | 6 | 6 |
| | 2 | 6 | 6 | 6 | 6 |
| 60 | 1 | 6 | 6 | 6 | 6 |
| | 2 | 6 | 6 | 6 | 6 |
| 70 | 1 | 6 | 6 | 6 | 6 |
| | 2 | 6 | 6 | 6 | 6 |
| 80 | 1 | 6 | 6 | 6 | 6 |
| | 2 | 6 | 6 | 6 | 6 |
| 95 | 1 | 6 | 6 | 6 | 6 |
| | 2 | 6 | 6 | 5 + 1 microprocessor node | 6 |
| 115 | 1 | 6 | 6 | 6 | 6 |
| | 2 | 6 | 6 | 5 | 6 |
| 130 | 1 | 6 | 6 | 5 + 1 microprocessor node | 6 |
| | 2 | 6 | 6 | 4 + 1 microprocessor node | 5 + 1 microprocessor node |

Note: OVS (Oversubscription) of the power system allows for more efficient use of the available system power.

Table 7. Compute nodes + two 225-watt² GPUs supported (high-line AC input, with 1300-watt power supply x6)

Six column table documenting the microprocessor SKU, # of microprocessor(s), non-redundant or N+1 with OVS, N=5, N+1 redundant, N=5, N+N redundant, N=3, and N+N redundant with OVS, N=3.

| Microprocessor SKU (W) | # of micro-processor(s) | Non-redundant or N+1 with OVS ¹ , N=5 | N+1 redundant, N=5 | N+N redundant, N=3 | N+N redundant with OVS ¹ , N=3 |
|------------------------|-------------------------|--|--------------------|---------------------------|---|
| 50 | 1 | 6 | 6 | 5 + 1 microprocessor node | 6 |
| | 2 | 6 | 6 | 5 | 6 |
| 60 | 1 | 6 | 6 | 5 | 6 |
| | 2 | 6 | 6 | 4 + 1 microprocessor node | 5 + 1 microprocessor node |
| 70 | 1 | 6 | 6 | 5 | 6 |
| | 2 | 6 | 6 | 4 + 1 microprocessor node | 5 + 1 microprocessor node |
| 80 | 1 | 6 | 6 | 5 | 6 |
| | 2 | 6 | 6 | 4 + 1 microprocessor node | 5 + 1 microprocessor node |
| 95 | 1 | 6 | 6 | 4 + 2 microprocessor node | 6 |
| | 2 | 6 | 6 | 4 | 5 |
| 115 | 1 | 6 | 6 | 4 + 1 microprocessor node | 5 + 1 microprocessor node |
| | 2 | 6 | 6 | 3 + 1 microprocessor node | 4 + 1 microprocessor node |
| 130 | 1 | 6 | 6 | 4 + 1 microprocessor node | 5 |
| | 2 | 6 | 6 | 3 + 1 microprocessor node | 4 + 1 microprocessor node |

Note: OVS (Oversubscription) of the power system allows for more efficient use of the available system power.

Table 8. Compute nodes + two 235-watt² GPUs supported (high-line AC input, with 1300-watt power supply x6)

Six column table documenting the microprocessor SKU, # of microprocessor(s), non-redundant or N+1 with OVS, N=5, N+1 redundant, N=5, N+N redundant, N=3, and N+N redundant with OVS, N=3.

Table 8. Compute nodes + two 235-watt² GPUs supported (high-line AC input, with 1300-watt power supply x6)
(continued)

| Microprocessor SKU (W) | # of micro-processor(s) | Non-redundant or N+1 with OVS ¹ , N=5 | N+1 redundant, N=5 | N+N redundant, N=3 | N+N redundant with OVS ¹ , N=3 |
|------------------------|-------------------------|--|--------------------|---------------------------|---|
| 50 | 1 | 6 | 6 | 5 + 1 microprocessor node | 6 |
| | 2 | 6 | 6 | 4 + 1 microprocessor node | 6 |
| 60 | 1 | 6 | 6 | 5 | 6 |
| | 2 | 6 | 6 | 4 + 1 microprocessor node | 5 + 1 microprocessor node |
| 70 | 1 | 6 | 6 | 5 | 6 |
| | 2 | 6 | 6 | 4 + 1 microprocessor node | 5 + 1 microprocessor node |
| 80 | 1 | 6 | 6 | 5 | 6 |
| | 2 | 6 | 6 | 4 + 1 microprocessor node | 5 + 1 microprocessor node |
| 95 | 1 | 6 | 6 | 4 + 2 microprocessor node | 5 + 1 microprocessor node |
| | 2 | 6 | 6 | 4 | 5 |
| 115 | 1 | 6 | 6 | 4 + 1 microprocessor node | 5 + 1 microprocessor node |
| | 2 | 6 | 6 | 3 + 1 microprocessor node | 4 + 1 microprocessor node |
| 130 | 1 | 6 | 6 | 4 | 5 |
| | 2 | 6 | 6 | 3 + 1 microprocessor node | 4 |

Note: OVS (Oversubscription) of the power system allows for more efficient use of the available system power.

Table 9. Compute nodes + two 300-watt² GPUs supported (high-line AC input, with 1300-watt power supply x6)

Six column table documenting the microprocessor SKU, # of microprocessor(s), non-redundant or N+1 with OVS, N=5, N+1 redundant, N=5, N+N redundant, N=3, and N+N redundant with OVS, N=3.

Table 9. Compute nodes + two 300-watt² GPUs supported (high-line AC input, with 1300-watt power supply x6)
(continued)

| Microprocessor SKU (W) | # of micro-processor(s) | Non-redundant or N+1 with OVS ¹ , N=5 | N+1 redundant, N=5 | N+N redundant, N=3 | N+N redundant with OVS ¹ , N=3 |
|------------------------|-------------------------|--|---------------------------|---------------------------|---|
| 50 | 1 | 6 | 6 | 4 + 2 microprocessor node | 5 + 1 microprocessor node |
| | 2 | 6 | 6 | 4 | 5 |
| 60 | 1 | 6 | 6 | 4 | 5 |
| | 2 | 6 | 6 | 3 + 2 microprocessor node | 4 + 2 microprocessor node |
| 70 | 1 | 6 | 6 | 4 | 5 |
| | 2 | 6 | 6 | 3 + 2 microprocessor node | 4 + 2 microprocessor node |
| 80 | 1 | 6 | 6 | 4 | 5 |
| | 2 | 6 | 6 | 3 + 2 microprocessor node | 4 + 2 microprocessor node |
| 95 | 1 | 6 | 6 | 4 | 4 + 2 microprocessor node |
| | 2 | 6 | 6 | 3 + 1 microprocessor node | 4 + 1 microprocessor node |
| 115 | 1 | 6 | 6 | 3 + 2 microprocessor node | 4 + 2 microprocessor node |
| | 2 | 6 | 5 + 1 microprocessor node | 3 | 3 + 2 microprocessor node |
| 130 | 1 | 6 | 6 | 3 + 2 microprocessor node | 4 + 1 microprocessor node |
| | 2 | 6 | 5 + 1 microprocessor node | 3 | 3 + 2 microprocessor node |

Note: OVS (Oversubscription) of the power system allows for more efficient use of the available system power.

1300-watt and 1500-watt power supply supportability

The following table provides the 1300-watt and 1500-watt power supply supportability to have better performance and power efficiency.

Table 10. 1300-watt and 1500-watt power supply supportability

Four column table documenting the quantity of 1300-watt power supplies, non-redundant, N+1 redundant, and N+N redundant.

| Quantity of 1300-watt power supplies | FPC power bank | | |
|--------------------------------------|----------------|---------------|---------------|
| | Non-redundant | N+1 redundant | N+N redundant |
| 2 | Support | | Non-support |
| 3 | | | |
| 4 | | | |
| 5 | | | |
| 6 | | | Support |

Note: When setting power redundancy policy through FPC after nodes are powered on, it is possible that the current power bank is not sufficient to allow N+1 or N+N configuration. Remove some or all of the nodes or lighten nodes configuration before the redundancy policy can be applied.

To install a power supply, complete the following steps.

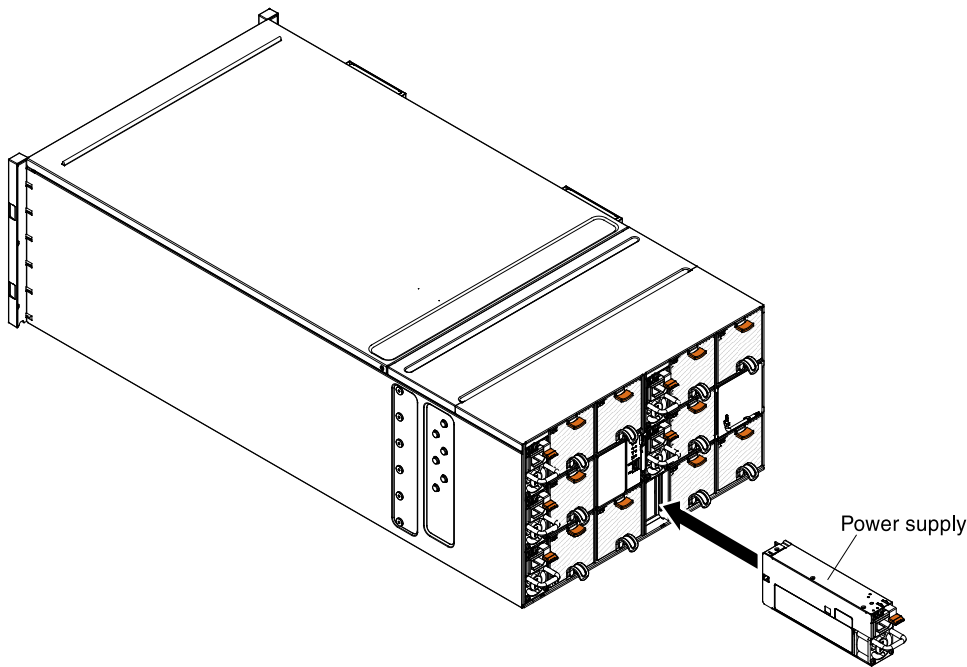

Figure 34. Installation of power supplies

Step 1. Grasp the power-supply handle and slide the power supply into the bay until it locks in place.

Step 2. Connect the power cord to the power supply:

1. Loosen the velcro strap that is attached to the power-supply, but do not remove it.
2. Align the power cord with the power-supply handle; then, secure the cord to the handle with the velcro strap.
3. Loop the power cord connector around and connect it to the power supply.

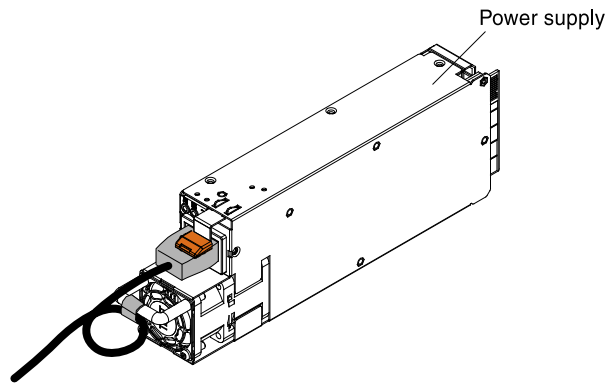

Figure 35. Power supply cord strain relief

4. Push the power cord back through the strain-relief ties to remove excess cable from the loop.

Removing and replacing FRUs

Only Lenovo service technicians are authorized to install or replace FRUs.

The illustrations in this document might differ slightly from your hardware.

Removing the chassis midplane

(Trained service technician only) Use these instructions to remove the chassis midplane from the NeXtScale n1200 Enclosure.

Before you remove the chassis midplane, complete the following steps:

1. Read [“Safety” on page iii](#) and [“Installation guidelines” on page 23](#).
2. Shut down the operating systems and turn off any compute nodes in the chassis. See the documentation that comes with the compute node for detailed instructions.
3. Open the release handles on the compute nodes and the management node, if one is installed, to disengage the nodes from the chassis midplane connectors.
4. Disconnect the chassis from power.
5. Disconnect all cables from the modules in the rear of the chassis.
6. Remove the components from rear and front of the chassis.

To remove the chassis midplane, complete the following steps.

- Step 1. Disengage the compute nodes in the front of the chassis.
- Step 2. Remove the fan power control and power supplies from the chassis.
- Step 3. Loosen the three captive screws on the top cover.
- Step 4. Rotate the top cover outwards.

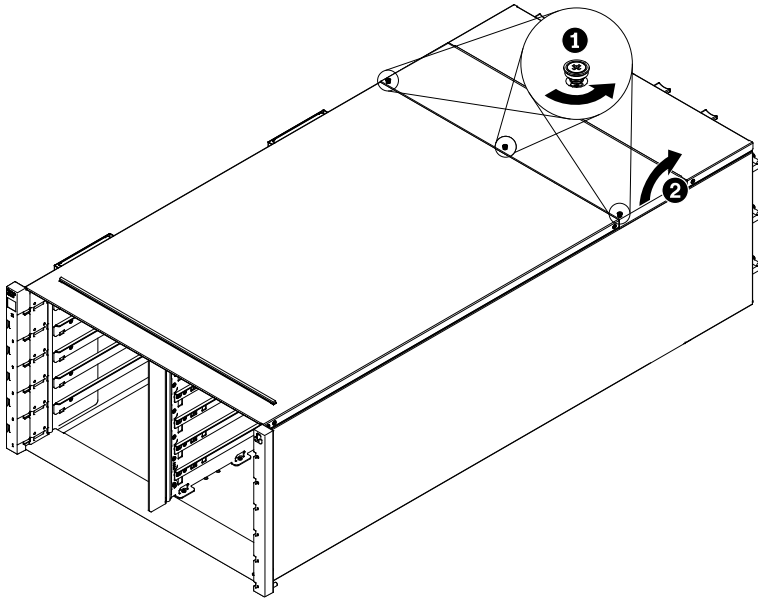

Figure 36. Top cover outward rotation

- Step 5. Loosen the three captive screws that secure the chassis midplane to the chassis.
- Step 6. Lift up the chassis midplane half way. Put a screwdriver or a stick in the middle of the chassis midplane so your hands are free.

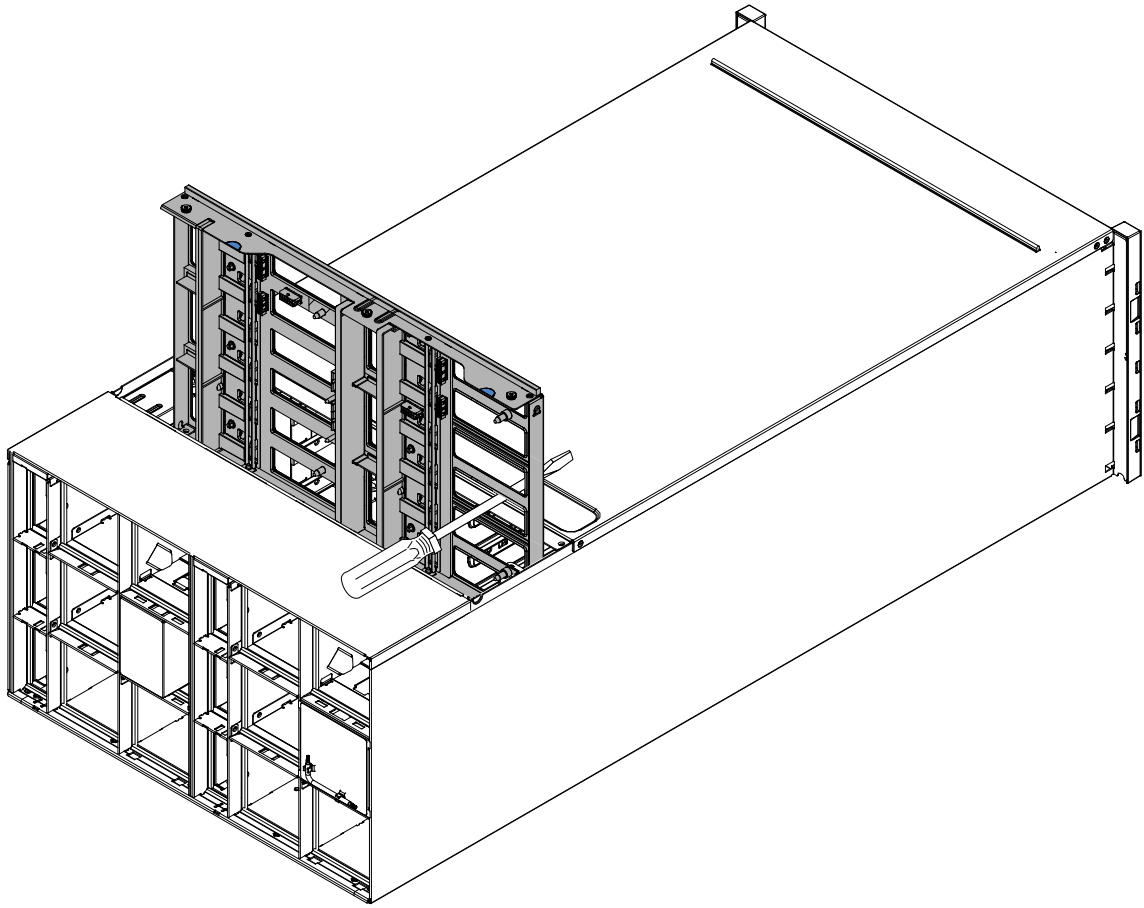

Figure 37. Removal of the chassis midplane from a chassis

Step 7. Unplug the two fan cables on chassis midplane

Step 8. Carefully grasp the chassis midplane and slide it away from the chassis.

Note: Make sure that you do not grasp the connectors on the chassis midplane. You could damage the connectors.

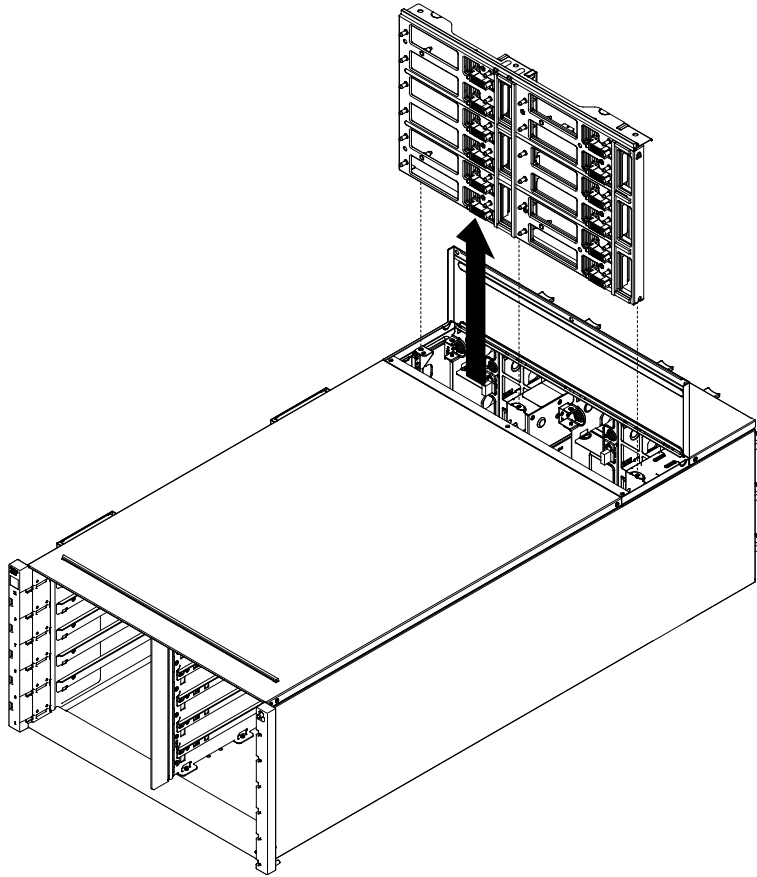

Figure 38. Removal of the chassis midplane from a chassis

Replacing the chassis midplane

(Trained service technician only) Use these instructions to install the chassis midplane in the NeXtScale n1200 Enclosure.

To install the chassis midplane, complete the following steps.

Step 1. Carefully align the chassis midplane with the guide pins in the chassis.

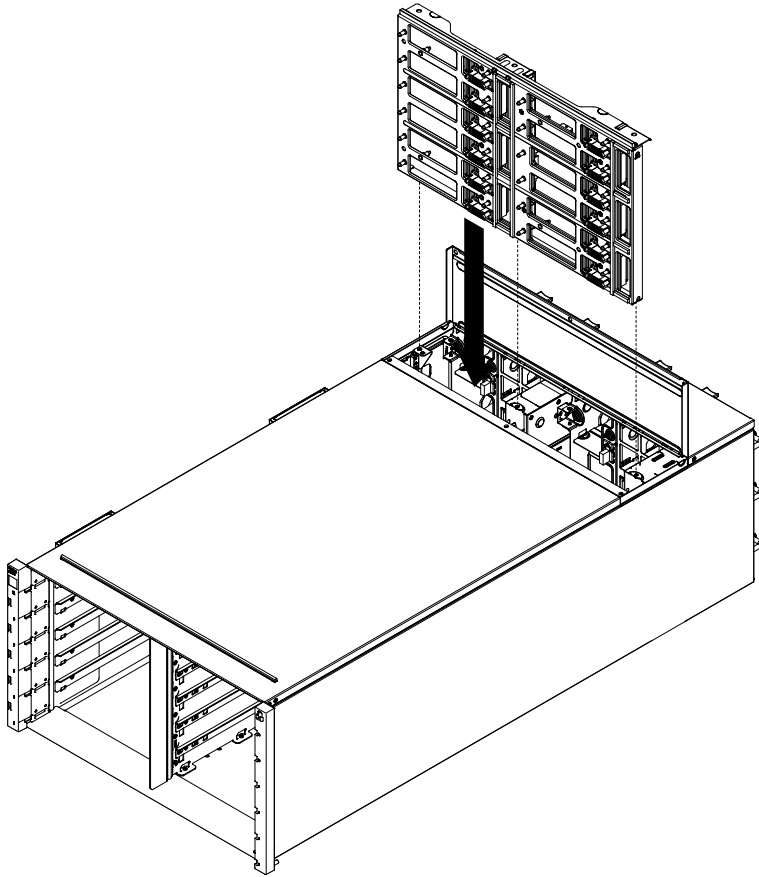

Figure 39. Installation of a chassis midplane into a chassis

- Step 2. Slide the chassis midplane half way into the chassis. Put a screwdriver or a stick in the middle of the chassis midplane so your hands are free.

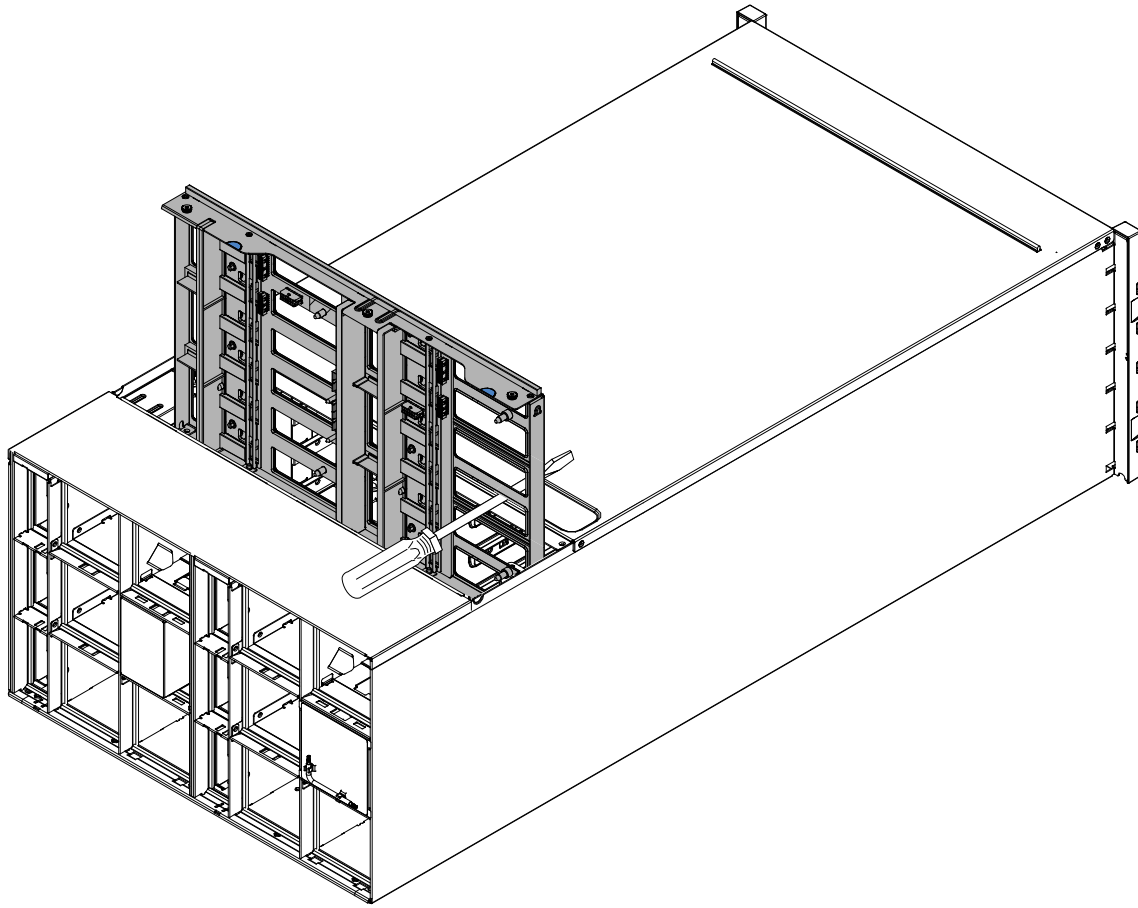

Figure 40. Installation of a chassis midplane into a chassis

Attention:

- You must hold the chassis midplane up against the top inside of the chassis shell and keep the chassis midplane vertical during installation. If the chassis midplane is not inserted correctly, the guide pins can contact the chassis midplane connectors and damage the connector pins.
- Do not grasp the connectors on the chassis midplane when you install it in the chassis. Touching the connectors might damage the connector pins.
- Make sure that the fan power control cable is out of the way when you slide the chassis midplane into the chassis.

Step 3. Connect the two cables back to fan power connectors and fan signal connectors back to the chassis midplane.

Step 4. Slide the chassis midplane all the way into the chassis until it stops.

Step 5. Tighten the three captive screws that secure the chassis midplane to the chassis.

Step 6. Rotate the top cover inwards.

Step 7. Tighten the three captive screws on the top cover.

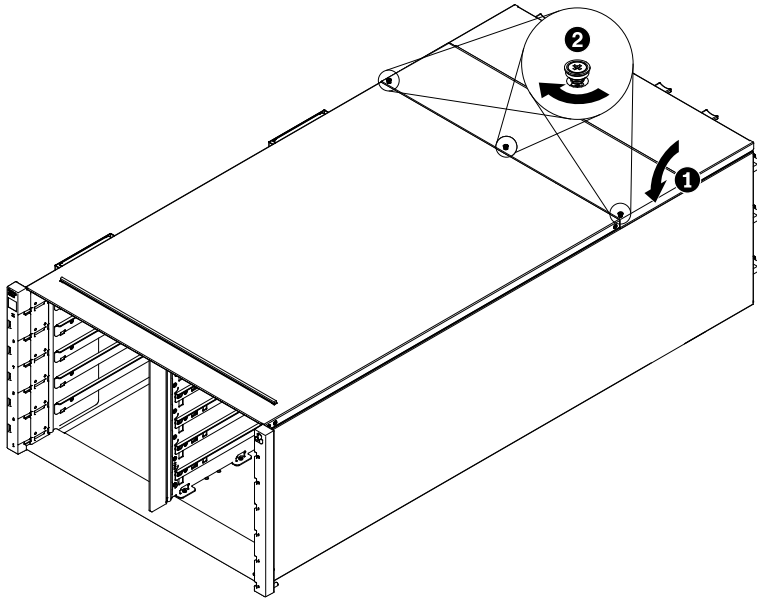

Figure 41. Top cover inward rotation

Reassemble the chassis and program the vital product data (VPD) that is stored on the card. Complete the following steps:

1. Reinstall the components that you removed from the rear of the chassis.
2. Connect any cables that you disconnected from the modules in the rear of the chassis.
3. Connect the chassis to power (see [“Replacing an AC power supply” on page 47](#)).
4. Write down new chassis midplane serial number (for example: **Y030UN34B063**) and UUID (for example: **2E2B686CC6B311E2907C6EAE8B16A49E**).
5. Update the server firmware to the latest level (see [“Configuration options” on page 74](#)).
6. Log in to the web interface (see [Chapter 4 “Using the web interface” on page 63](#)).
7. Go to **System Information** section, click on the **Midplane VPD** tab.
8. Update the new chassis midplane serial number and UUID onto the fan power control (see [“System information options” on page 71](#)).
9. Close the release handles on the compute nodes in order to seat the nodes in the chassis midplane connectors.
10. Restart any compute nodes that you shut down. See the documentation that comes with the compute node for detailed instructions.

Chapter 4. Using the web interface

Use this information to help you navigate the FPC web-based graphical user interface and manage components in the NeXtScale n1200 Enclosure.

Starting the web interface

Start the FPC web-based graphical user interface to manage components in the chassis.

You can access the fan power control web interface through an Ethernet connection by establishing a session with the IP address of the FPC. If you are connecting to the FPC for the first time, you might have to change the Internet protocol properties on the client computer.

Open your web browser and enter the IP address of the FPC in the address or URL field.

- If the IP address was assigned through a DHCP server, get the IP address from your network administrator.
- The FPC has the following default settings:
 - IP address: 192.168.0.100
 - Subnet: 255.255.255.0
 - User ID: USERID (all capital letters)
 - Password: PASSWORD (note the number zero, not the letter O, in PASSWORD)

Resetting the FPC to manufacturing defaults

You can restore the primary FPC to manufacturing defaults through the FPC web interface.

Read the safety information in [“Safety” on page iii](#) and [“Installation guidelines” on page 23](#).

To reset the FPC to manufacturing defaults, complete the following steps.

Step 1. Press the reset button for more than 4 seconds to reset the FPC.

Chapter 5. Web interface options

Use this information to help understand the structure and content of the FPC web interface.

Launch the FPC web interface to select the FPC settings that you want to view or change. The menu bar contains options that you can use to configure and manage the chassis. The options that are in the menu bar are described in the following sections.

Summary options

You can view the overall system status, a list of outstanding events that require immediate attention, and the overall status of the compute nodes and other components in the chassis on the Summary tab.

The following illustration shows the Summary page for the FPC web interface. The page opens with the chassis front view tab displayed.

| Node | Width | Height | Status | Reset / Reset | Node | Width | Height | Status | Reset / Reset |
|------|-------|--------|------------|---|------|-------|--------|------------|---|
| 11 | NA | 0 U | No Present | <input type="button" value="Reset"/> <input type="button" value="Reset"/> | 12 | NA | 0 U | No Present | <input type="button" value="Reset"/> <input type="button" value="Reset"/> |
| 09 | NA | 0 U | No Present | <input type="button" value="Reset"/> <input type="button" value="Reset"/> | 10 | NA | 0 U | No Present | <input type="button" value="Reset"/> <input type="button" value="Reset"/> |
| 07 | NA | 0 U | No Present | <input type="button" value="Reset"/> <input type="button" value="Reset"/> | 08 | NA | 0 U | No Present | <input type="button" value="Reset"/> <input type="button" value="Reset"/> |
| 05 | NA | 0 U | No Present | <input type="button" value="Reset"/> <input type="button" value="Reset"/> | 06 | Half | 1 U | Power On | <input type="button" value="Reset"/> <input type="button" value="Reset"/> |
| 03 | Half | 1 U | Power Off | <input type="button" value="Reset"/> <input type="button" value="Reset"/> | 04 | NA | 0 U | No Present | <input type="button" value="Reset"/> <input type="button" value="Reset"/> |
| 01 | NA | 0 U | No Present | <input type="button" value="Reset"/> <input type="button" value="Reset"/> | 02 | Half | 1 U | Power Off | <input type="button" value="Reset"/> <input type="button" value="Reset"/> |

Click the chassis rear view drop down dialog box to display the System Information Quick View for overall system information.

Management Module

| | | |
|-------------------------|---|--|
| Name | Fan & Power Control Board (FPCB) | |
| Status | <input checked="" type="checkbox"/> Normal <input type="button" value="Reset"/> | |
| Firmware Version | FHET21C-2.04 | |
| PSOC Version | ver. 1.27 | |
| Boot-up Flash | First | |
| Identify LED | Off | <input checked="" type="radio"/> Turn Off <input type="radio"/> Turn On <input type="radio"/> Blink <input type="button" value="Apply"/> |
| Check Log LED | Off | <input type="button" value="Turn Off"/> |

The power supply status table is placed in chassis rear view tab.

PSU

| PSU | Status | Ratings | AC-IN | EPOW | Throttle | DC-PG |
|------|----------------|--------------|--------------|---------------|---------------|------------|
| PSU1 | No Present | 0 W | 0 V | Normal | Normal | No |
| PSU2 | No Present | 0 W | 0 V | Normal | Normal | No |
| PSU3 | No Present | 0 W | 0 V | Normal | Normal | No |
| PSU4 | Present | 900 W | 205 V | Normal | Normal | Yes |
| PSU5 | No Present | 0 W | 0 V | Normal | Normal | No |
| PSU6 | No Present | 0 W | 0 V | Normal | Normal | No |

The system fan status table is placed in chassis rear view tab.

Fan

| Bay | Status | Type | Bay | Status | Type |
|----------|----------------|-----------------|-----------|----------------|-----------------|
| 1 | Present | Standard | 6 | Present | Standard |
| 2 | Present | Standard | 7 | Present | Standard |
| 3 | Present | Standard | 8 | Present | Standard |
| 4 | Present | Standard | 9 | Present | Standard |
| 5 | Present | Standard | 10 | Present | Standard |

Power options

There are five sections in the power tab.

Power overview

Power Overview

Total Chassis Power Consumption (AC-in)

Min. 39 W Avg. 39 W Max. 40 W

Total Fans Power Consumption

21.7 W

Node Power Consumption

| Node | Min. (W) | Avg. (W) | Max. (W) |
|-----------|------------|------------|------------|
| 01 | No Present | No Present | No Present |
| 02 | 0 | 0 | 0 |
| 03 | 0 | 0 | 0 |
| 04 | No Present | No Present | No Present |

Voltage overview

| Status | Probe Name | Reading | Non-CriticalLower | Non-CriticalUpper | CriticalLower | CriticalUpper | Non-RecoverableLower | Non-RecoverableUpper |
|--------|------------|----------|-------------------|-------------------|---------------|---------------|----------------------|----------------------|
| | 12V_SENSE | 11.840 V | N/A | N/A | 10.816 V | 13.248 V | N/A | N/A |
| | 3V3_SENSE | 3.3075 V | N/A | N/A | 2.9750 V | 3.6225 V | N/A | N/A |
| | 5V_SENSE | 5.022 V | N/A | N/A | 4.563 V | 5.589 V | N/A | N/A |
| | VBAT_SENSE | 3.0096 V | N/A | N/A | 1.7952 V | N/A | N/A | N/A |

PSU configuration

PSU Configuration

Redundancy Mode

| | |
|-----------------------|---------|
| Redundancy Mode | N + N |
| Oversubscription Mode | OVS Off |

Apply

Smart Redundancy

| | |
|------------------|---------|
| Smart Redundancy | Disable |
|------------------|---------|

Apply

Redundancy Mode: You can choose one of the three options:

1. No Redundancy: System can be throttled or shut down if one or more power supplies are in faulty condition.
2. N+1: Have one of the properly installed power supply as the redundant power supply. Therefore, there is no impact to system operation or performance if any one of the power supplies is in faulty condition.
3. N+N: Have half of the properly installed power supplies as redundant power supplies. Therefore, there is no impact to system operation or performance if any half of the power supplies have failed, given that Oversubscription mode is not enabled. For example, 6 power supplies are properly installed, 3 of them can fail without any impact when N+N and no Oversubscription is applied.

Ove-subscription Mode: Oversubscription allows you to take advantage of the extra power from the redundant power supply when the power supplies are in healthy condition. When the redundancy fails, the power supply will shut down within 1 second if system power loading is not corrected after the time limit. FPC takes the action of node throttling at such power emergency. Chassis performance can be impacted even in redundancy mode if oversubscription is also enabled. Oversubscription is applied only with N+1 or N+N redundancy modes.

Smart Redundancy: There are three scanning periods are offered: 10, 30, and 60 minutes respectively. The shorter the scanning period, the faster FPC adjusts number of hibernate power supplies to optimize power supply efficiency when system load changes. With shorter scanning period, power supplies are also turned on and off more frequently when system loading fluctuates, which could reduce the power supply life. Disable smart redundancy will always keep all power supplies active.

Power cap

Power Capping Policy

Chassis Capping ▾
 Chassis Capping
 Nodes Capping

Chassis Power Capping/Saving

| Node | Capping | | Saving |
|---------|--------------------------|---|--|
| Chassis | <input type="checkbox"/> | <input type="checkbox"/> W (Range: 219 W ~ 288 W) | <input checked="" type="radio"/> Disable <input type="radio"/> Mode 1 <input type="radio"/> Mode 2 <input type="radio"/> Mode 3 |

Apply

Power saving can be applied with power capping simultaneously.

Three column table for documenting the mode, title, and description.

| Mode | Title | Description |
|---------|----------------------------|--|
| Disable | Static maximum performance | The system runs at full speed (no throttling) regardless of the workload. |
| Mode 1 | Static minimum power | The system runs in a throttled state (defined by the implementation) regardless of the workload. |

Power restore policy

Power Restore Policy

| <input checked="" type="checkbox"/> | Node | Status | <input type="checkbox"/> | Node | Status |
|-------------------------------------|------|---------|--------------------------|------|---------|
| <input checked="" type="checkbox"/> | 11 | Disable | <input type="checkbox"/> | 12 | Disable |
| <input checked="" type="checkbox"/> | 09 | Disable | <input type="checkbox"/> | 10 | Disable |
| <input checked="" type="checkbox"/> | 07 | Disable | <input type="checkbox"/> | 08 | Disable |
| <input checked="" type="checkbox"/> | 05 | Disable | <input type="checkbox"/> | 06 | Disable |
| <input checked="" type="checkbox"/> | 03 | Disable | <input type="checkbox"/> | 04 | Disable |
| <input checked="" type="checkbox"/> | 01 | Disable | <input type="checkbox"/> | 02 | Disable |

Apply

Cooling options

There are three sections in the cooling tab.

Cooling overview

Fan speed is displayed in RPM. Error log is asserted when fan speed is below lower critical threshold.

Cooling Overview

Probe List

| Status | Probe Name | Reading | LowerNon-Critical | UpperNon-Critical | LowerCritical | UpperCritical | LowerNon-Recoverable | UpperNon-Recoverable |
|--------|-------------|----------|-------------------|-------------------|---------------|---------------|----------------------|----------------------|
| | FAN_Tach_1A | 2752 RPM | N/A | N/A | 1472 RPM | N/A | N/A | N/A |
| | FAN_Tach_1B | 2112 RPM | N/A | N/A | 1472 RPM | N/A | N/A | N/A |
| | FAN_Tach_2A | 2816 RPM | N/A | N/A | 1472 RPM | N/A | N/A | N/A |
| | FAN_Tach_2B | 2176 RPM | N/A | N/A | 1472 RPM | N/A | N/A | N/A |
| | FAN_Tach_3A | 2816 RPM | N/A | N/A | 1472 RPM | N/A | N/A | N/A |
| | FAN_Tach_3B | 2176 RPM | N/A | N/A | 1472 RPM | N/A | N/A | N/A |
| | FAN_Tach_4A | 2752 RPM | N/A | N/A | 1472 RPM | N/A | N/A | N/A |
| | FAN_Tach_4B | 2176 RPM | N/A | N/A | 1472 RPM | N/A | N/A | N/A |
| | FAN_Tach_5A | 2816 RPM | N/A | N/A | 1472 RPM | N/A | N/A | N/A |
| | FAN_Tach_5B | 2112 RPM | N/A | N/A | 1472 RPM | N/A | N/A | N/A |
| | FAN_Tach_6A | 2688 RPM | N/A | N/A | 1472 RPM | N/A | N/A | N/A |
| | FAN_Tach_6B | 2240 RPM | N/A | N/A | 1472 RPM | N/A | N/A | N/A |
| | FAN_Tach_7A | 2752 RPM | N/A | N/A | 1472 RPM | N/A | N/A | N/A |
| | FAN_Tach_7B | 2176 RPM | N/A | N/A | 1472 RPM | N/A | N/A | N/A |
| | FAN_Tach_8A | 2816 RPM | N/A | N/A | 1472 RPM | N/A | N/A | N/A |
| | FAN_Tach_8B | 2112 RPM | N/A | N/A | 1472 RPM | N/A | N/A | N/A |
| | FAN_Tach_9A | 2752 RPM | N/A | N/A | 1472 RPM | N/A | N/A | N/A |
| | FAN_Tach_9B | 2176 RPM | N/A | N/A | 1472 RPM | N/A | N/A | N/A |

PSU fan speed

PSU Fan Speed

| Fan | Speed (RPM) | Speed (% of Max.) | Status |
|-------------|-------------|-------------------|---------------|
| Fan1 | 0 | 0% | No Present |
| Fan2 | 0 | 0% | No Present |
| Fan3 | 0 | 0% | No Present |
| Fan4 | 5528 | 10% | Normal |
| Fan5 | 0 | 0% | No Present |
| Fan6 | 0 | 0% | No Present |

Acoustic mode

Acoustic Mode Selection

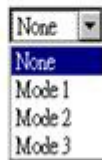

To reduce the noise level of the chassis during run-time, you can configure the chassis to three different acoustic modes:

- Mode 1: System fan speed is capped at 28% duty (7.5 bels)
- Mode 2: System fan speed is capped at 34% duty (7.8 bels)
- Mode 3: System fan speed is capped at 40% duty (8.1 bels)

Notes:

1. Acoustic modes can only apply to the entire chassis as a whole.
2. When acoustic modes are applied, nodes workload is also capped to avoid over-heating.
3. If acoustic mode is enabled when ambient temperature is above 27°C indefinitely, it is possible that nodes could throttle due to overheat. In some cases, the nodes might shut down.

System information options

System information tab contains the fixed vital product data (VPD). There are three sections in the system information tab.

Chassis VPD

Chassis VPD

Backup Restore

| Name | Value |
|--------------------------|--------------------------------------|
| Chassis Name | Lenovo System n1200 Enclosure Server |
| Machine Type/Model | 545611A |
| UUID | 053F16117A5811E39B1A851BF26A62C8 |
| Chassis Hardware Version | Pass6 |

Edit

Midplane VPD

Midplane VPD

Backup Restore

| Name | Value |
|-----------------------|----------------------------------|
| Midplane Name | Air Mid-plane |
| Card Serial Number | Y030UN34B04R |
| Card UUID | 2E2B686CC6B311E2907C6EAE8B16A49E |
| Card Hardware Version | Pass4 |
| Card FRU Part Number | 46W2907 |

Edit

For backup, restoring, and updating the information on chassis name and midplane VPD, complete the following steps:

1. For chassis name and VPD information backup, click the **Backup** button to save the chassis name, serial number of the chassis midplane, the existing universally unique identifier (UUID) information from chassis midplane, hardware revision, and FRU serial number onto FPC USB for future restore purposes.
2. For chassis name and VPD information restoring, click the **Restore** button to load the previously backed up file containing the chassis name, serial number of the chassis midplane, the existing universally unique identifier (UUID) information from chassis midplane, hardware revision, and FRU serial number from the FPC USB key onto new FPC.
3. For chassis name or VPD information updating, click the **Edit** button to modify the chassis midplane VPD value. Then, click the **Apply** button to update the changes.

FPC VPD

FPC VPD

| Name | Value |
|------------------------|----------------------------------|
| FPC Name | FPC Card |
| Card Serial Number | Y031UN34H07N |
| Card UUID | 41424344313233340000000000000000 |
| Card Hardware Version | Pass5 |
| Card FRU Serial Number | 00Y8605 |

Events log options

The FPC event log contains a list of all events that are received from all devices in the chassis.

To access the FPC event log and configure event recipient notifications in the FPC web interface, open the **Events** menu and click **Event Log**. The following illustration shows the Event Log page. Note that event IDs are not shown in the Event Log page, by default. They must be manually enabled to display.

Event Log

| Severity | Date/Time | Description |
|----------|---------------------|--|
| | 2013-01-01 00:03:03 | EvtLogDisabled: Event Logging Disabled sensor, Log Area Reset/Cleared was asserted |
| | 2013-01-02 15:17:49 | Node_Reseat_User: Slot Or Connector sensor, Slot device (System Board number 2) was asserted |
| | 2013-01-02 15:21:40 | Node_No_Present: Slot Or Connector sensor, Slot device (System Board number 2) was asserted |
| | 2013-01-02 15:26:35 | Node_DC_OFF: Slot Or Connector sensor, Slot device (System Board number 3) was asserted |
| | 2013-01-02 15:30:59 | Node_DC_OFF: Slot Or Connector sensor, Slot device (System Board number 2) was asserted |
| | 2013-01-02 15:33:00 | Node_No_Present: Slot Or Connector sensor, Slot device (System Board number 2) was asserted |
| | 2013-01-01 00:00:02 | Node_No_Present: Slot Or Connector sensor, Slot device (System Board number 1) was asserted |
| | 2013-01-01 00:00:02 | Node_No_Present: Slot Or Connector sensor, Slot device (System Board number 2) was asserted |
| | 2013-01-01 00:00:02 | Node_No_Present: Slot Or Connector sensor, Slot device (System Board number 4) was asserted |
| | 2013-01-01 00:00:02 | Node_No_Present: Slot Or Connector sensor, Slot device (System Board number 5) was asserted |
| | 2013-01-01 00:00:02 | Node_No_Present: Slot Or Connector sensor, Slot device (System Board number 6) was asserted |
| | 2013-01-01 00:00:02 | Node_No_Present: Slot Or Connector sensor, Slot device (System Board number 7) was asserted |
| | 2013-01-01 00:00:02 | Node_No_Present: Slot Or Connector sensor, Slot device (System Board number 8) was asserted |
| | 2013-01-01 00:00:02 | Node_No_Present: Slot Or Connector sensor, Slot device (System Board number 9) was asserted |
| | 2013-01-01 00:00:02 | Node_No_Present: Slot Or Connector sensor, Slot device (System Board number 10) was asserted |
| | 2013-01-01 00:00:02 | Node_No_Present: Slot Or Connector sensor, Slot device (System Board number 11) was asserted |
| | 2013-01-01 00:00:02 | Node_No_Present: Slot Or Connector sensor, Slot device (System Board number 12) was asserted |
| | 2013-01-03 01:14:29 | Node_No_Present: Slot Or Connector sensor, Slot device (System Board number 3) was asserted |
| | 2013-01-01 00:00:02 | Node_No_Present: Slot Or Connector sensor, Slot device (System Board number 1) was asserted |

USB recovery

USB Recovery

Backup Current Configuration to USB

Apply

Restore from USB Backup Configuration

Apply

Restore to Default Configuration

Apply

Configuration options

Configuration tabs resides settings that are used to manage fan power control. There are eight sections in the configuration tab.

Firmware Update SMTP SNMP PEF Network Configuration Time Setting User Configuration Web Service

Firmware update

There are two phases to the firmware update process. During the firmware upload stage, you can choose path to fetch the firmware image. FPC checks the image header information for validation

Firmware Update

Firmware Upload

| | | |
|--------------------|---------------------------------|--------|
| Firmware Type | BMC | |
| Firmware File Path | 浏览... Note_STC_FHET03A-1.00.pdf | Upload |

Selected file is not valid for MergePoint® EMS Firmware update.
No file was specified.

Once a valid firmware image is uploaded, a firmware image confirmation table appears with **Preserve Setting** check box. If the firmware update proceeds with preserve setting checked, FPC configurations are kept and applied after the firmware is updated. The settings preserved include:

- SMTP
- SNMP
- PEF
- Network configuration
- Time setting (always kept regardless if **Preserve Setting** is checked)
- User account
- Web service

Note: FPC will automatically reboot if you choose to cancel the firmware update process after uploading the firmware image.

Firmware Update

Firmware Upload

| | | |
|--------------------|---|---------------------------------------|
| Firmware Type | BMC | |
| Firmware File Path | <input type="text" value="ibm_fw_fpc_finet03A-1.00_anyos_noarch.rpm"/> <input type="button" value="浏览..."/> | <input type="button" value="Upload"/> |

Firmware Image

| Current Version | New Version | Preserve Settings | Status |
|-----------------|-------------|--------------------------|--------|
| 1.00 | 1.00 | <input type="checkbox"/> | None |

Upload Completed. Please click "Update" to continue, or "Cancel" to stop.
System will be rebooted after Update/Cancel process.

| | |
|---------------------------------------|---------------------------------------|
| <input type="button" value="Update"/> | <input type="button" value="Cancel"/> |
|---------------------------------------|---------------------------------------|

During updating, you are directed to a loading page where all FPC functions are locked.

Firmware



10% Completed

Updating, please wait. It won't stop processing due to leave this page.

Once the progress reaches 100%, FPC automatically reboots and you need to log in again to access FPC Web interface.

Firmware

MergePointR EMS Firmware Image has been updated successfully.

The MergePointR EMS has been reset. You will not be able to access the MergePointR EMS with this browser session. Please close and reconnect to the MergePointR EMS using new browser session.

SMTP/SNMP/PEF tabs

Configured SMTP and SNMP traps allow you to monitor chassis for selected events. SMTP/SNMP trap event types can be set in the PEF (Platform Event Filter) tab. SMTP email-alert and SNMP trap can be enabled, configured, and tested in the SMTP and SNMP tabs respectively. **Global Alerting Enable** in PEF tab also needs to be checked to enable email alerts. For SNMP trap type, check the **Generate PEF** box for targeted type of events. For SMTP trap, all the events will be sent to destination email address when **Global Alerting Enable** is checked.

Note: Community Name displays/configures the SNMP community name using only alphabet and numerical values. The value must not be empty.

SMTP

Destination Email Addresses

| | Enable | Destination Email Address | Email Description | Test |
|---------------|--------------------------|---------------------------|------------------------|---|
| Email Alert 1 | <input type="checkbox"/> | <input type="text"/> | MergePoint email alert | <input type="button" value="Send Alert 1"/> |
| Email Alert 2 | <input type="checkbox"/> | <input type="text"/> | MergePoint email alert | <input type="button" value="Send Alert 2"/> |
| Email Alert 3 | <input type="checkbox"/> | <input type="text"/> | MergePoint email alert | <input type="button" value="Send Alert 3"/> |
| Email Alert 4 | <input type="checkbox"/> | <input type="text"/> | MergePoint email alert | <input type="button" value="Send Alert 4"/> |

SMTP (email) Server Address

| | |
|-----------------|--------------------------------------|
| SMTP IP Address | <input type="text" value="0.0.0.0"/> |
|-----------------|--------------------------------------|

SMTP Authentication

| | |
|---------------|---|
| Enable | <input type="checkbox"/> Anonymous account will be used when authentication is disabled. |
| Username | <input type="text"/> |
| Password | <input type="password"/> |
| STARTTLS Mode | <input type="text" value="AUTO"/> |
| SASL Mode | <input type="text" value="AUTO"/> |

SNMP

IPv4 Destination List

| | Enable | IPv4 Address | Test |
|--------------------|--------------------------|--------------------------------------|---|
| IPv4 Destination 1 | <input type="checkbox"/> | <input type="text" value="0.0.0.0"/> | <input type="button" value="Send Test Trap"/> |
| IPv4 Destination 2 | <input type="checkbox"/> | <input type="text" value="0.0.0.0"/> | <input type="button" value="Send Test Trap"/> |
| IPv4 Destination 3 | <input type="checkbox"/> | <input type="text" value="0.0.0.0"/> | <input type="button" value="Send Test Trap"/> |
| IPv4 Destination 4 | <input type="checkbox"/> | <input type="text" value="0.0.0.0"/> | <input type="button" value="Send Test Trap"/> |

IPv6 Destination List

| | Enable | IPv6 Address | Test |
|--------------------|--------------------------|----------------------|---|
| IPv6 Destination 1 | <input type="checkbox"/> | <input type="text"/> | <input type="button" value="Send Test Trap"/> |
| IPv6 Destination 2 | <input type="checkbox"/> | <input type="text"/> | <input type="button" value="Send Test Trap"/> |
| IPv6 Destination 3 | <input type="checkbox"/> | <input type="text"/> | <input type="button" value="Send Test Trap"/> |
| IPv6 Destination 4 | <input type="checkbox"/> | <input type="text"/> | <input type="button" value="Send Test Trap"/> |

Community String

| | |
|----------------|-------------------------------------|
| Community Name | <input type="text" value="public"/> |
|----------------|-------------------------------------|

PEF

Platform Event Filters (PEF) List

| Filter Name | Generate PEF |
|--|--------------------------|
| All Type, Fan Critical Deassert Filter | <input type="checkbox"/> |
| All Type, Power Supply Critical Deassert Filter | <input type="checkbox"/> |
| All Type, Slot Or Connector Critical Deassert Filter | <input type="checkbox"/> |
| All Type, Voltage Critical Deassert Filter | <input type="checkbox"/> |

Network configuration

Network configuration allows you to modify networking parameters: Hostname, DNS Domain Name, Auto Negotiation Mode, Network Speed, Duplex Mode, IP Version (IPv4, IPv6) Enable/Disable, IP Address, IP Source (Static, DHCP), Gateway, Subnet Mask, DNS Server, VLAN, and so on.

Network Configuration

Refresh

General Settings

| | |
|-----------------|---------|
| Mode | 1 |
| Host Name | IBM-FPC |
| DNS Domain Name | IBM.com |

Network Interface Configuration

| Name | IF Enabled | IPv4 Enabled | IPv4 Address | IPv6 Enabled | IPv6 Address |
|------|------------|--------------|---------------|--------------|--------------|
| eth0 | Enabled | Enabled | 192.168.0.100 | Disabled | :::0 |

Apply

Click on the item of Network Interface Configuration leads to the detail network settings.

Network Configuration

Refresh

i Changes to the NIC IP address settings will close all user sessions and require IP address settings. All other changes will require the NIC to be reset, which may cause a brief loss in connectivity. Changes may not take effect immediately, and require a refresh.

Network Interface Settings

| | |
|------------------|--|
| Device Type | Dedicated |
| MAC Address | 6c:ae:8b:08:10:fc |
| Auto Negotiation | <input checked="" type="radio"/> On <input type="radio"/> Off |
| Network Speed | 10 Mb |
| Duplex Mode | <input checked="" type="radio"/> Full <input type="radio"/> Half |

General Settings

| | |
|------------------------------|-------------------------------------|
| Enable Dynamic DNS | <input type="checkbox"/> |
| Use DHCP for DNS Domain Name | <input type="checkbox"/> |
| Respond to ARP | <input checked="" type="checkbox"/> |

IPv4 Settings

| | |
|---|-------------------------------------|
| Enabled | <input checked="" type="checkbox"/> |
| Use DHCP | <input type="checkbox"/> |
| IP Address | 192.168.0.100 |
| Subnet Mask | 255.255.255.0 |
| Gateway | 192.168.0.1 |
| Use DHCP to obtain DNS server addresses | <input type="checkbox"/> |
| Preferred DNS Server | |
| Alternate DNS Server | |

IPv6 Settings

| | |
|---|----------------------------------|
| Enabled | <input type="checkbox"/> |
| Auto Configuration | <input type="checkbox"/> |
| IP Address 1 | <input type="text" value="::0"/> |
| Gateway | <input type="text" value=""/> |
| Link Local Address | <input type="text" value="::0"/> |
| IP Address 2 | <input type="text" value="::0"/> |
| Use DHCP to obtain DNS server addresses | <input type="checkbox"/> |
| Preferred DNS Server | <input type="text" value=""/> |
| Alternate DNS Server | <input type="text" value=""/> |

VLAN Settings

| | |
|----------------|--------------------------------|
| Enable VLAN ID | <input type="checkbox"/> |
| VLAN ID | <input type="text" value="0"/> |
| Priority | <input type="text" value="0"/> |

Time setting

This tab is used to configure system time. Select date and time and apply. Once they are set, the time is always kept even if you restore settings to default or uncheck **Preserve Setting** during firmware update.

bestfit,bestfit,sfx)="graphics:graphic5E3AF767B26472FFD524F0F9286E5AB2"

User account

There are three types of user roles:

- Administrator: Has full access to all the Web pages and can modify all the settings and configurations.
- Operator: Has full access to all the Web pages except **User Account** page. Operator can only see its own account in the **User Account** page and no modification is allowed in the account page.
- User: Has full access and modification rights to all the pages except the following pages in **Configuration** tab: SMTP/SNMP/PEF/Network Configuration/User Account/Web Service. Only viewing right is allowed on these pages. No modifications.

The following illustration displays the User Account tab if you are either User or Operator.

User Configuration

To configure a particular user, click the User ID. If Password policy check is enabled, password strength checking will be enabled while updating user configuration.

Password Policy Check Enable

| User ID | State | User Name | User Role | IPMI LAN Privilege | IPMI Serial Privilege | Serial Over LAN |
|---------|---------|-----------|-----------|--------------------|-----------------------|-----------------|
| 2 | Enabled | USER | User | None | None | Disabled |

The following illustration displays the User Account tab if you are the Administrator.

To configure a particular user, click the User ID. If Password policy check is enabled, password strength checking will be enabled while updating user configuration.

Password Policy Check Enable

Refresh

| User ID | State | User Name | User Role | IPMI LAN Privilege | IPMI Serial Privilege | Serial Over LAN |
|---------|----------|-----------|---------------|--------------------|-----------------------|-----------------|
| 1 | Disabled | | None | None | None | Disabled |
| 2 | Disabled | | None | None | None | Disabled |
| 3 | Enabled | USERID | Administrator | Admin | Admin | Enabled |
| 4 | Disabled | | None | None | None | Disabled |
| 5 | Disabled | | None | None | None | Disabled |
| 6 | Disabled | | None | None | None | Disabled |
| 7 | Disabled | | None | None | None | Disabled |
| 8 | Disabled | | None | None | None | Disabled |
| 9 | Disabled | | None | None | None | Disabled |
| 10 | Disabled | | None | None | None | Disabled |
| 11 | Disabled | | None | None | None | Disabled |
| 12 | Disabled | | None | None | None | Disabled |
| 13 | Disabled | | None | None | None | Disabled |
| 14 | Disabled | | None | None | None | Disabled |
| 15 | Disabled | | None | None | None | Disabled |
| 16 | Disabled | | None | None | None | Disabled |

Click on one of the accounts leads to **User Configuration**. You can enable/disable/delete account, set user name, set/change password, and select user privileges here. When **Password Policy Check Enable** box is checked, account password needs to be at least 8 characters with numbers, letters, and a character to be considered a successful set.

Note: You can assign account username in **User Name** field with up to 16 characters using alphanumeric characters a-z, A-Z and 0-9, - (hyphen) and _ (underscore). Click the **Apply Changes** button. If validation fails, the interface displays an error message.

Notes: You can set/change password in **New Password** field using up to 20 printable US-ASCII (Code: 33-126) characters. Password must contain characters from three of the following four categories:

1. English uppercase characters (A through Z)
2. English lowercase characters (a through z)
3. Base 10 digits (0 through 9)
4. Non-alphabetic characters (for example, !, \$, #, %)

If validation fails, the interface displays an error message.

User Configuration

[Back](#)

Password Policy

Password Policy Check Enabled No

General

User ID
Enable User
User Name
Change Password
New Password
Confirm New Password

User Privileges

User Role
IPMI LAN Privilege
IPMI Serial Privilege
Enable Serial Over LAN

[Delete](#) [Apply](#)

Web service

Web service let you configure different HTTP/HTTPS ports for connection and the Web page timeout period.

Web Service

Web Server

HTTP Port Number
HTTPS Port Number
Timeout seconds
Max Sessions
Active Sessions

[Apply](#)

Appendix A. Fan power control (FPC) error codes

This section details the fan power control (FPC) error codes.

Fan power control (FPC) diagnostic error codes can be generated when the server starts up or while the server is running. Fan power control (FPC) codes are logged in the FPC event log in the server.

For each event code, the following fields are displayed:

Event identifier

An identifier that uniquely identifies an event.

Event description

The logged message string that appears for an event.

Explanation

Additional information to explain why the event occurred.

Severity

An indication of the level of concern for the condition. The severity is abbreviated in the event log to the first character. The following severities can be displayed:

Table 11. Event severity levels

Two column table for documenting the severity and description.

| Severity | Description |
|-----------------|---|
| Informational | An informational message is something that was recorded for audit purposes, usually a user action or a change of states that is normal behavior. |
| Normal | An normal message is for audit purposes only, usually stand for system normal operating status or user action. |
| Warning | A warning is not as severe as an error, but if possible, the condition should be corrected before it becomes an error. It might also be a condition that requires additional monitoring or maintenance. |
| Non-Recoverable | An error typically indicates a component failure or critical condition where the component or system environment may not be able to recover without service action or local determination. |
| Critical | An Critical typically indicates a failure or critical condition that impairs service or an expected function. |

User response

Indicate the actions that you should take to resolve the event.

Perform the steps listed in this section in the order shown until the problem is solved. After you perform all of the actions that are described in this field, if you cannot solve the problem, contact Lenovo support.

The following is the list of the fan power control (FPC) error codes and suggested actions to correct the detected problems.

List of fan power control (FPC) error codes

This section details the fan power control (FPC) error codes.

- **02 : EvtLogDisabled: Event Logging Disabled sensor, Log Area Reset/Cleared was asserted.**

FPC system event log is cleared.

Severity

Normal

Serviceable

Automatically notify support

User Response

1. N/A

- **03 : EvtLogDisabled: Event Logging Disabled sensor, system event log full was asserted**

Warning is asserted when system event log is at least 75% full. Error is asserted when System Event Log is 100% full.

Severity

Critical

Serviceable

Automatically notify support

User Response

Complete the following steps:

1. User should clear system event log.

- **04 : EvtLogDisabled: Event Logging Disabled sensor, system event log almost full was asserted**

Warning is asserted when system event log is at least 75% full.

Severity

Warning

Serviceable

Automatically notify support

User Response

1. User should be aware that system event log is almost full. No action needed.

- **10 : FAN_Tach_1A: Fan sensor, failure event was asserted, reading value : %RPM (Threshold : 1472RPM)**

Asserted when Fan tach reading is below threshold RPM.

Severity

Critical

Serviceable

Automatically notify support

User Response

Complete the following steps:

1. If error is not de-asserted after several minutes, check all ten fans are installed.
2. Reseat fan module one or two times. If error still persist, replace fan module.

- **11 : FAN_Tach_1B: Fan sensor, failure event was asserted, reading value : %RPM (Threshold : 1472RPM)**

Asserted when Fan tach reading is below threshold RPM.

Severity

Critical

Serviceable

Automatically notify support

User Response

Complete the following steps:

1. If error is not de-asserted after several minutes, check all ten fans are installed.
2. Reseat fan module one or two times. If error still persist, replace fan module.

- **12 : FAN_Tach_2A: Fan sensor, failure event was asserted, reading value : %RPM (Threshold : 1472RPM)**

Asserted when Fan tach reading is below threshold RPM.

Severity

Critical

Serviceable

Automatically notify support

User Response

Complete the following steps:

1. If error is not de-asserted after several minutes, check all ten fans are installed.
2. Reseat fan module one or two times. If error still persist, replace fan module.

- **13 : FAN_Tach_2B: Fan sensor, failure event was asserted, reading value : %RPM (Threshold : 1472RPM)**

Asserted when Fan tach reading is below threshold RPM.

Severity

Critical

Serviceable

Automatically notify support

User Response

Complete the following steps:

1. If error is not de-asserted after several minutes, check all ten fans are installed.
2. Reseat fan module one or two times. If error still persist, replace fan module.

- **14 : FAN_Tach_3A: Fan sensor, failure event was asserted, reading value : %RPM (Threshold : 1472RPM)**

Asserted when Fan tach reading is below threshold RPM.

Severity

Critical

Serviceable**Automatically notify support****User Response**

Complete the following steps:

1. If error is not de-asserted after several minutes, check all ten fans are installed.
2. Reseat fan module one or two times. If error still persist, replace fan module.

- **15 : FAN_Tach_3B: Fan sensor, failure event was asserted, reading value : %RPM (Threshold : 1472RPM)**

Asserted when Fan tach reading is below threshold RPM.

Severity

Critical

Serviceable**Automatically notify support****User Response**

Complete the following steps:

1. If error is not de-asserted after several minutes, check all ten fans are installed.
2. Reseat fan module one or two times. If error still persist, replace fan module.

- **16 : FAN_Tach_4A: Fan sensor, failure event was asserted, reading value : %RPM (Threshold : 1472RPM)**

Asserted when Fan tach reading is below threshold RPM.

Severity

Critical

Serviceable**Automatically notify support****User Response**

Complete the following steps:

1. If error is not de-asserted after several minutes, check all ten fans are installed.
2. Reseat fan module one or two times. If error still persist, replace fan module.

- **17 : FAN_Tach_4B: Fan sensor, failure event was asserted, reading value : %RPM (Threshold : 1472RPM)**

Asserted when Fan tach reading is below threshold RPM.

Severity

Critical

Serviceable**Automatically notify support****User Response**

Complete the following steps:

1. If error is not de-asserted after several minutes, check all ten fans are installed.
2. Reseat fan module one or two times. If error still persist, replace fan module.

- **18 : FAN_Tach_5A: Fan sensor, failure event was asserted, reading value : %RPM (Threshold : 1472RPM)**

Asserted when Fan tach reading is below threshold RPM.

Severity

Critical

Serviceable

Automatically notify support

User Response

Complete the following steps:

1. If error is not de-asserted after several minutes, check all ten fans are installed.
2. Reseat fan module one or two times. If error still persist, replace fan module.

- **19 : FAN_Tach_5B: Fan sensor, failure event was asserted, reading value : %RPM (Threshold : 1472RPM)**

Asserted when Fan tach reading is below threshold RPM.

Severity

Critical

Serviceable

Automatically notify support

User Response

Complete the following steps:

1. If error is not de-asserted after several minutes, check all ten fans are installed.
2. Reseat fan module one or two times. If error still persist, replace fan module.

- **1A : FAN_Tach_6A: Fan sensor, failure event was asserted, reading value : %RPM (Threshold : 1472RPM)**

Asserted when Fan tach reading is below threshold RPM.

Severity

Critical

Serviceable

Automatically notify support

User Response

Complete the following steps:

1. If error is not de-asserted after several minutes, check all ten fans are installed.
2. Reseat fan module one or two times. If error still persist, replace fan module.

- **1B : FAN_Tach_6B: Fan sensor, failure event was asserted, reading value : %RPM (Threshold : 1472RPM)**

Asserted when Fan tach reading is below threshold RPM.

Severity

Critical

Serviceable

Automatically notify support

User Response

Complete the following steps:

1. If error is not de-asserted after several minutes, check all ten fans are installed.
2. Reseat fan module one or two times. If error still persist, replace fan module.

- **1C : FAN_Tach_7A: Fan sensor, failure event was asserted, reading value : %RPM (Threshold : 1472RPM)**

Asserted when Fan tach reading is below threshold RPM.

Severity

Critical

Serviceable

Automatically notify support

User Response

Complete the following steps:

1. If error is not de-asserted after several minutes, check all ten fans are installed.
2. Reseat fan module one or two times. If error still persist, replace fan module.

- **1D : FAN_Tach_7B: Fan sensor, failure event was asserted, reading value : %RPM (Threshold : 1472RPM)**

Asserted when Fan tach reading is below threshold RPM.

Severity

Critical

Serviceable

Automatically notify support

User Response

Complete the following steps:

1. If error is not de-asserted after several minutes, check all ten fans are installed.
2. Reseat fan module one or two times. If error still persist, replace fan module.

- **1E : FAN_Tach_8A: Fan sensor, failure event was asserted, reading value : %RPM (Threshold : 1472RPM)**

Asserted when Fan tach reading is below threshold RPM.

Severity

Critical

Serviceable

Automatically notify support

User Response

Complete the following steps:

1. If error is not de-asserted after several minutes, check all ten fans are installed.

2. Reseat fan module one or two times. If error still persist, replace fan module.

- **1F : FAN_Tach_8B: Fan sensor, failure event was asserted, reading value : %RPM (Threshold : 1472RPM)**

Asserted when Fan tach reading is below threshold RPM.

Severity

Critical

Serviceable

Automatically notify support

User Response

Complete the following steps:

1. If error is not de-asserted after several minutes, check all ten fans are installed.
2. Reseat fan module one or two times. If error still persist, replace fan module.

- **20 : FAN_Tach_9A: Fan sensor, failure event was asserted, reading value : %RPM (Threshold : 1472RPM)**

Asserted when Fan tach reading is below threshold RPM.

Severity

Critical

Serviceable

Automatically notify support

User Response

Complete the following steps:

1. If error is not de-asserted after several minutes, check all ten fans are installed.
2. Reseat fan module one or two times. If error still persist, replace fan module.

- **21 : FAN_Tach_9B: Fan sensor, failure event was asserted, reading value : %RPM (Threshold : 1472RPM)**

Asserted when Fan tach reading is below threshold RPM.

Severity

Critical

Serviceable

Automatically notify support

User Response

Complete the following steps:

1. If error is not de-asserted after several minutes, check all ten fans are installed.
2. Reseat fan module one or two times. If error still persist, replace fan module.

- **22 : FAN_Tach_10A: Fan sensor, failure event was asserted, reading value : %RPM (Threshold : 1472RPM)**

Asserted when Fan tach reading is below threshold RPM.

Severity

Critical

Serviceable

Automatically notify support

User Response

Complete the following steps:

1. If error is not de-asserted after several minutes, check all ten fans are installed.
2. Reseat fan module one or two times. If error still persist, replace fan module.

- **23 : FAN_Tach_10B: Fan sensor, failure event was asserted, reading value : %RPM (Threshold : 1472RPM)**

Asserted when Fan tach reading is below threshold RPM.

Severity

Critical

Serviceable

Automatically notify support

User Response

Complete the following steps:

1. If error is not de-asserted after several minutes, check all ten fans are installed.
2. Reseat fan module one or two times. If error still persist, replace fan module.

- **30 : 12V_Sense**

Asserted when voltage sensed on 12V power rail is lower than lower critical threshold (10.816V) or higher than upper critical threshold (13.248 V)

Severity

Critical

Serviceable

Automatically notify support

User Response

Complete the following steps:

1. Reseat FPC module. If 12V_SENSE error is still asserted, replace FPC module.

- **31 : 3V3_Sense**

Asserted when voltage sensed on 3V power rail is lower than lower critical threshold (2.975 V) or higher than upper critical threshold (3.623 V)

Severity

Critical

Serviceable

Automatically notify support

User Response

Complete the following steps:

1. Reseat FPC module. If 3V3_SENSE error is still asserted, replace FPC module.

- **32 : 5V_Sense**

Asserted when voltage sensed on 5V power rail is lower than lower critical threshold (4.563 V) or higher than upper critical threshold (5.589 V)

Severity

Critical

Serviceable

Automatically notify support

User Response

Complete the following steps:

1. Reseat FPC module. If 5V_SENSE error is still asserted, replace FPC module.

- **33 : VBAT_Sense**

Asserted when voltage sensed on coin battery output voltage is lower than lower critical threshold (1.795V)

Severity

Critical

Serviceable

Automatically notify support

User Response

1. Replace coin battery on FPC.

- **40 : PS1_FANFault**

Power supply 1 fan has fail condition.

Severity

Critical

Serviceable

Automatically notify support

User Response

Complete the following steps:

1. Check PSU power cord, reseal PSU.
2. If PSU Fan Fault is still asserted, replace PSU.

- **41 : PS1_Thermal_Fault**

Power supply fan has thermal related fault, possibly over-heated condition.

Severity

Critical

Serviceable

Automatically notify support

User Response

Complete the following steps:

1. Check PSU power cord, reseal PSU.
2. If PSU Thermal Fault is still asserted, replace PSU.

- **42 : PS1_12V_OV_Fault**

Power supply is having 12V power Over-Voltage condition

Severity

Critical

Serviceable

Automatically notify support

User Response

Complete the following steps:

1. Check if PSU power cord is plugged.
2. Reseat components in the following order, continue down the list if OV fault is not de-asserted:
Power supply, Mid-plane, All Nodes.
3. If PSU 12V OV Fault is still asserted, replace PSU.

• **43 : PS1_12V_UV_Fault**

Power supply is having 12V power Under-Voltage condition.

Severity

Critical

Serviceable

Automatically notify support

User Response

Complete the following steps:

1. Check if PSU power cord is plugged.
2. Reseat components in the following order, continue down the list if OV fault is not de-asserted:
Power supply, Mid-plane, All Nodes.
3. If PSU 12V UV Fault is still asserted, replace PSU.

• **44 : PS1_12V_AUX_Fault**

Power supply is having faulty condition in providing 12V AUX power.

Severity

Critical

Serviceable

Automatically notify support

User Response

Complete the following steps:

1. Check if PSU power cord is plugged.
2. Reseat components in the following order, continue down the list if OV fault is not de-asserted:
Power supply, Mid-plane, All Nodes.
3. If PSU 12V AUX Fault is still asserted, replace PSU.

• **45 : PS1_EPOW_Assert**

AC power provided to the indicated power supply is lost

Severity

Non-Recoverable

Serviceable

Automatically notify support

User Response

Complete the following steps:

1. Make sure PSU power cord is properly plugged in. Check if AC power is stable.

- **46 : PS1_Throttle_Assert**

Power supply is having over-current condition.

Severity

Critical

Serviceable

Automatically notify support

User Response

Complete the following steps:

1. Make sure PSU power cord is properly plugged in.
2. Un-install node one by one to identify if any of the node is causing the OC condition.
3. If Throttle is still asserted when all nodes are removed from chassis, do the following: Unplug power supplies power cord and removed all power supplies from chassis. Plug power cord back into power supply while power supply is outside of chassis. If PSU orange LED is turned off under this circumstance, replace mid-plane. If LED is still lit, replace PSU.

- **47 : PS1_AC_Lo_Line**

Power supply is connected to 110v AC.

Severity

Info

Serviceable

Automatically notify support

User Response

1. No user action needed.

- **48 : PS1_OT_Warning**

Power supply internal temperature has reached warning threshold. Over temperature fault is possibly to occur if condition not relieved.

Severity

Warning

Serviceable

Automatically notify support

User Response

Complete the following steps:

1. Make sure that there is no obstruction blocking power supplies and system fans' air way.
2. Make sure that power supplies does not have any fault condition.
3. Make sure that room temperature is maintained at required level.

4. Make sure that all fan modules are installed and operating properly.
5. Make sure that power supplies fans are running with higher speed than system fan.
6. If condition persists after above inspection, reseal power supply.
7. If OT warning continues to present after power supply reseal, replace power supply.

- **49 : PS1_No_Present**

Power supply was removed from chassis.

Severity

Info

Serviceable

Automatically notify support

User Response

1. No user action needed.

- **50 : PS2_FANFault**

Power supply 2fan has fail condition.

Severity

Critical

Serviceable

Automatically notify support

User Response

Complete the following steps:

1. Check PSU power cord, reseal PSU.
2. If PSU Fan Fault is still asserted, replace PSU.

- **51 : PS2_Thermal_Fault**

Power supply fan has thermal related fault, possibly over-heated condition.

Severity

Critical

Serviceable

Automatically notify support

User Response

Complete the following steps:

1. Check PSU power cord, reseal PSU.
2. If PSU Thermal Fault is still asserted, replace PSU.

- **52 : PS2_12V_OV_Fault**

Power supply is having 12V power Over-Voltage condition

Severity

Critical

Serviceable

Automatically notify support

User Response

Complete the following steps:

1. Check if PSU power cord is plugged.
2. Reseat components in the following order, continue down the list if OV fault is not de-asserted:
Power supply, Mid-plane, All Nodes.
3. If PSU 12V OV Fault is still asserted, replace PSU.

- **53 : PS2_12V_UV_Fault**

Power supply is having 12V power Under-Voltage condition.

Severity

Critical

Serviceable

Automatically notify support

User Response

Complete the following steps:

1. Check if PSU power cord is plugged.
2. Reseat components in the following order, continue down the list if OV fault is not de-asserted:
Power supply, Mid-plane, All Nodes.
3. If PSU 12V UV Fault is still asserted, replace PSU.

- **54 : PS2_12V_AUX_Fault**

Power supply is having faulty condition in providing 12V AUX power.

Severity

Critical

Serviceable

Automatically notify support

User Response

Complete the following steps:

1. Check if PSU power cord is plugged.
2. Reseat components in the following order, continue down the list if OV fault is not de-asserted:
Power supply, Mid-plane, All Nodes.
3. If PSU 12V AUX Fault is still asserted, replace PSU.

- **55 : PS2_EPOW_Assert**

AC power provided to the indicated power supply is lost

Severity

Non-Recoverable

Serviceable

Automatically notify support

User Response

Complete the following steps:

1. Make sure PSU power cord is properly plugged in. Check if AC power is stable.

- **56 : PS2_Throttle_Assert**

Power supply is having over-current condition.

Severity

Critical

Serviceable

Automatically notify support

User Response

Complete the following steps:

1. Make sure PSU power cord is properly plugged in.
2. Un-install node one by one to identify if any of the node is causing the OC condition.
3. If Throttle is still asserted when all nodes are removed from chassis, do the following: Unplug power supplies power cord and removed all power supplies from chassis. Plug power cord back into power supply while power supply is outside of chassis. If PSU orange LED is turned off under this circumstance, replace mid-plane. If LED is still lit, replace PSU.

- **57 : PS2_AC_Lo_Line**

Power supply is connected to 110v AC.

Severity

Info

Serviceable

Automatically notify support

User Response

1. No user action needed.

- **58 : PS2_OT_Warning**

Power supply internal temperature has reached warning threshold. Over temperature fault is possibility to occur if condition not relieved.

Severity

Warning

Serviceable

Automatically notify support

User Response

Complete the following steps:

1. Make sure that there is no obstruction blocking power supplies and system fans' air way.
2. Make sure that power supplies does not have any fault condition.
3. Make sure that room temperature is maintained at required level.
4. Make sure that all fan modules are installed and operating properly.
5. Make sure that power supplies fans are running with higher speed than system fan.
6. If condition persists after above inspection, reseal power supply.
7. If OT warning continues to present after power supply reseal, replace power supply.

- **59 : PS2_No_Present**

Power supply was removed from chassis.

Severity

Info

Serviceable

Automatically notify support

User Response

1. No user action needed.

- **60 : PS3_FANFault**

Power supply 3 fan has fail condition.

Severity

Critical

Serviceable

Automatically notify support

User Response

Complete the following steps:

1. Check PSU power cord, reseal PSU.
2. If PSU Fan Fault is still asserted, replace PSU.

- **61 : PS3_Thermal_Fault**

Power supply fan has thermal related fault, possibly over-heated condition.

Severity

Critical

Serviceable

Automatically notify support

User Response

Complete the following steps:

1. Check PSU power cord, reseal PSU.
2. If PSU Thermal Fault is still asserted, replace PSU.

- **62 : PS3_12V_OV_Fault**

Power supply is having 12V power Over-Voltage condition

Severity

Critical

Serviceable

Automatically notify support

User Response

Complete the following steps:

1. Check if PSU power cord is plugged.

2. Reseat components in the following order, continue down the list if OV fault is not de-asserted:
Power supply, Mid-plane, All Nodes.
3. If PSU 12V OV Fault is still asserted, replace PSU.

- **63 : PS3_12V_UV_Fault**

Power supply is having 12V power Under-Voltage condition.

Severity

Critical

Serviceable

Automatically notify support

User Response

Complete the following steps:

1. Check if PSU power cord is plugged.
2. Reseat components in the following order, continue down the list if OV fault is not de-asserted:
Power supply, Mid-plane, All Nodes.
3. If PSU 12V UV Fault is still asserted, replace PSU.

- **64 : PS3_12V_AUX_Fault**

Power supply is having faulty condition in providing 12V AUX power.

Severity

Critical

Serviceable

Automatically notify support

User Response

Complete the following steps:

1. Check if PSU power cord is plugged.
2. Reseat components in the following order, continue down the list if OV fault is not de-asserted:
Power supply, Mid-plane, All Nodes.
3. If PSU 12V AUX Fault is still asserted, replace PSU.

- **65 : PS3_EPOW_Assert**

AC power provided to the indicated power supply is lost

Severity

Non-Recoverable

Serviceable

Automatically notify support

User Response

Complete the following steps:

1. Make sure PSU power cord is properly plugged in. Check if AC power is stable.

- **66 : PS3_Throttle_Assert**

Power supply is having over-current condition.

Severity

Critical

Serviceable**Automatically notify support****User Response**

Complete the following steps:

1. Make sure PSU power cord is properly plugged in.
2. Un-install node one by one to identify if any of the node is causing the OC condition.
3. If Throttle is still asserted when all nodes are removed from chassis, do the following: Unplug power supplies power cord and removed all power supplies from chassis. Plug power cord back into power supply while power supply is outside of chassis. If PSU orange LED is turned off under this circumstance, replace mid-plane. If LED is still lit, replace PSU.

- **67 : PS3_AC_Lo_Line**

Power supply is connected to 110v AC.

Severity

Info

Serviceable**Automatically notify support****User Response**

1. No user action needed.

- **68 : PS3_OT_Warning**

Power supply internal temperature has reached warning threshold. Over temperature fault is possibly to occur if condition not relieved.

Severity

Warning

Serviceable**Automatically notify support****User Response**

Complete the following steps:

1. Make sure that there is no obstruction blocking power supplies and system fans' air way.
2. Make sure that power supplies does not have any fault condition.
3. Make sure that room temperature is maintained at required level.
4. Make sure that all fan modules are installed and operating properly.
5. Make sure that power supplies fans are running with higher speed than system fan.
6. If condition persists after above inspection, reseal power supply.
7. If OT warning continues to present after power supply reseal, replace power supply.

- **69 : PS3_No_Present**

Power supply was removed from chassis.

Severity

Info

Serviceable

Automatically notify support

User Response

1. No user action needed.

- **70 : PS4_FANFault**

Power supply 4 fan has fail condition.

Severity

Critical

Serviceable

Automatically notify support

User Response

Complete the following steps:

1. Check PSU power cord, reseal PSU.
2. If PSU Fan Fault is still asserted, replace PSU.

- **71 : PS4_Thermal_Fault**

Power supply fan has thermal related fault, possibly over-heated condition.

Severity

Critical

Serviceable

Automatically notify support

User Response

Complete the following steps:

1. Check PSU power cord, reseal PSU.
2. If PSU Thermal Fault is still asserted, replace PSU.

- **72 : PS4_12V_OV_Fault**

Power supply is having 12V power Over-Voltage condition

Severity

Critical

Serviceable

Automatically notify support

User Response

Complete the following steps:

1. Check if PSU power cord is plugged.
2. Reseat components in the following order, continue down the list if OV fault is not de-asserted:
Power supply, Mid-plane, All Nodes.
3. If PSU 12V OV Fault is still asserted, replace PSU.

- **73 : PS4_12V_UV_Fault**

Power supply is having 12V power Under-Voltage condition.

Severity

Critical

Serviceable**Automatically notify support****User Response**

Complete the following steps:

1. Check if PSU power cord is plugged.
2. Reseat components in the following order, continue down the list if OV fault is not de-asserted: Power supply, Mid-plane, All Nodes.
3. If PSU 12V UV Fault is still asserted, replace PSU.

- **74 : PS4_12V_AUX_Fault**

Power supply is having faulty condition in providing 12V AUX power.

Severity

Critical

Serviceable**Automatically notify support****User Response**

Complete the following steps:

1. Check if PSU power cord is plugged.
2. Reseat components in the following order, continue down the list if OV fault is not de-asserted: Power supply, Mid-plane, All Nodes.
3. If PSU 12V AUX Fault is still asserted, replace PSU.

- **75 : PS4_EPOW_Assert**

AC power provided to the indicated power supply is lost

Severity

Non-Recoverable

Serviceable**Automatically notify support****User Response**

Complete the following steps:

1. Make sure PSU power cord is properly plugged in. Check if AC power is stable.

- **76 : PS4_Throttle_Assert**

Power supply is having over-current condition.

Severity

Critical

Serviceable**Automatically notify support****User Response**

Complete the following steps:

1. Make sure PSU power cord is properly plugged in.
2. Un-install node one by one to identify if any of the node is causing the OC condition.
3. If Throttle is still asserted when all nodes are removed from chassis, do the following: Unplug power supplies power cord and removed all power supplies from chassis. Plug power cord back into power supply while power supply is outside of chassis. If PSU orange LED is turned off under this circumstance, replace mid-plane. If LED is still lit, replace PSU.

- **77 : PS4_AC_Lo_Line**

Power supply is connected to 110v AC.

Severity

Info

Serviceable

Automatically notify support

User Response

1. No user action needed.

- **78 : PS4_OT_Warning**

Power supply internal temperature has reached warning threshold. Over temperature fault is possibility to occur if condition not relieved.

Severity

Warning

Serviceable

Automatically notify support

User Response

Complete the following steps:

1. Make sure that there is no obstruction blocking power supplies and system fans' air way.
2. Make sure that power supplies does not have any fault condition.
3. Make sure that room temperature is maintained at required level.
4. Make sure that all fan modules are installed and operating properly.
5. Make sure that power supplies fans are running with higher speed than system fan.
6. If condition persists after above inspection, reseal power supply.
7. If OT warning continues to present after power supply reseal, replace power supply.

- **79 : PS4_No_Present**

Power supply was removed from chassis.

Severity

Info

Serviceable

Automatically notify support

User Response

1. No user action needed.

- **80 : PS5_FANFault**

Power supply 5 fan has fail condition.

Severity

Critical

Serviceable

Automatically notify support

User Response

Complete the following steps:

1. Check PSU power cord, reseal PSU.
2. If PSU Fan Fault is still asserted, replace PSU.

• **81 : PS5_Thermal_Fault**

Power supply fan has thermal related fault, possibly over-heated condition.

Severity

Critical

Serviceable

Automatically notify support

User Response

Complete the following steps:

1. Check PSU power cord, reseal PSU.
2. If PSU Thermal Fault is still asserted, replace PSU.

• **82 : PS5_12V_OV_Fault**

Power supply is having 12V power Over-Voltage condition

Severity

Critical

Serviceable

Automatically notify support

User Response

Complete the following steps:

1. Check if PSU power cord is plugged.
2. Reseat components in the following order, continue down the list if OV fault is not de-asserted:
Power supply, Mid-plane, All Nodes.
3. If PSU 12V OV Fault is still asserted, replace PSU.

• **83 : PS5_12V_UV_Fault**

Power supply is having 12V power Under-Voltage condition.

Severity

Critical

Serviceable

Automatically notify support

User Response

Complete the following steps:

1. Check if PSU power cord is plugged.
2. Reseat components in the following order, continue down the list if OV fault is not de-asserted:
Power supply, Mid-plane, All Nodes.
3. If PSU 12V UV Fault is still asserted, replace PSU.

- **84 : PS5_12V_AUX_Fault**

Power supply is having faulty condition in providing 12V AUX power.

Severity

Critical

Serviceable

Automatically notify support

User Response

Complete the following steps:

1. Check if PSU power cord is plugged.
2. Reseat components in the following order, continue down the list if OV fault is not de-asserted:
Power supply, Mid-plane, All Nodes.
3. If PSU 12V AUX Fault is still asserted, replace PSU.

- **85 : PS5_EPOW_Assert**

AC power provided to the indicated power supply is lost

Severity

Non-Recoverable

Serviceable

Automatically notify support

User Response

Complete the following steps:

1. Make sure PSU power cord is properly plugged in. Check if AC power is stable.

- **86 : PS5_Throttle_Assert**

Power supply is having over-current condition.

Severity

Critical

Serviceable

Automatically notify support

User Response

Complete the following steps:

1. Make sure PSU power cord is properly plugged in.
2. Un-install node one by one to identify if any of the node is causing the OC condition.
3. If Throttle is still asserted when all nodes are removed from chassis, do the following: Unplug power supplies power cord and removed all power supplies from chassis. Plug power cord back into power supply while power supply is outside of chassis. If PSU orange LED is turned off under this circumstance, replace mid-plane. If LED is still lit, replace PSU.

- **87 : PS5_AC_Lo_Line**

Power supply is connected to 110v AC.

Severity

Info

Serviceable

Automatically notify support

User Response

1. No user action needed.

- **88 : PS5_OT_Warning**

Power supply internal temperature has reached warning threshold. Over temperature fault is possibly to occur if condition not relieved.

Severity

Warning

Serviceable

Automatically notify support

User Response

Complete the following steps:

1. Make sure that there is no obstruction blocking power supplies and system fans' air way.
2. Make sure that power supplies does not have any fault condition.
3. Make sure that room temperature is maintained at required level.
4. Make sure that all fan modules are installed and operating properly.
5. Make sure that power supplies fans are running with higher speed than system fan.
6. If condition persists after above inspection, reseal power supply.
7. If OT warning continues to present after power supply reseal, replace power supply.

- **89 : PS5_No_Present**

Power supply was removed from chassis.

Severity

Info

Serviceable

Automatically notify support

User Response

1. No user action needed.

- **90 : PS6_FANFault**

Power supply 6 fan has fail condition.

Severity

Critical

Serviceable

Automatically notify support

User Response

Complete the following steps:

1. Check PSU power cord, reseal PSU.
2. If PSU Fan Fault is still asserted, replace PSU.

- **91 : PS6_Thermal_Fault**

Power supply fan has thermal related fault, possibly over-heated condition.

Severity

Critical

Serviceable**Automatically notify support****User Response**

Complete the following steps:

1. Check PSU power cord, reseal PSU.
2. If PSU Thermal Fault is still asserted, replace PSU.

- **92 : PS6_12V_OV_Fault**

Power supply is having 12V power Over-Voltage condition

Severity

Critical

Serviceable**Automatically notify support****User Response**

Complete the following steps:

1. Check if PSU power cord is plugged.
2. Reseat components in the following order, continue down the list if OV fault is not de-asserted:
Power supply, Mid-plane, All Nodes.
3. If PSU 12V OV Fault is still asserted, replace PSU.

- **93 : PS6_12V_UV_Fault**

Power supply is having 12V power Under-Voltage condition.

Severity

Critical

Serviceable**Automatically notify support****User Response**

Complete the following steps:

1. Check if PSU power cord is plugged.
2. Reseat components in the following order, continue down the list if UV fault is not de-asserted:
Power supply, Mid-plane, All Nodes.
3. If PSU 12V UV Fault is still asserted, replace PSU.

- **94 : PS6_12V_AUX_Fault**

Power supply is having faulty condition in providing 12V AUX power.

Severity

Critical

Serviceable

Automatically notify support

User Response

Complete the following steps:

1. Check if PSU power cord is plugged.
2. Reseat components in the following order, continue down the list if OV fault is not de-asserted: Power supply, Mid-plane, All Nodes.
3. If PSU 12V AUX Fault is still asserted, replace PSU.

• **95 : PS6_EPOW_Assert**

AC power provided to the indicated power supply is lost

Severity

Non-Recoverable

Serviceable

Automatically notify support

User Response

Complete the following steps:

1. Make sure PSU power cord is properly plugged in. Check if AC power is stable.

• **96 : PS6_Throttle_Assert**

Power supply is having over-current condition.

Severity

Critical

Serviceable

Automatically notify support

User Response

Complete the following steps:

1. Make sure PSU power cord is properly plugged in.
2. Un-install node one by one to identify if any of the node is causing the OC condition.
3. If Throttle is still asserted when all nodes are removed from chassis, do the following: Unplug power supplies power cord and removed all power supplies from chassis. Plug power cord back into power supply while power supply is outside of chassis. If PSU orange LED is turned off under this circumstance, replace mid-plane. If LED is still lit, replace PSU.

• **97 : PS6_AC_Lo_Line**

Power supply is connected to 110v AC.

Severity

Info

Serviceable

Automatically notify support

User Response

1. No user action needed.

- **98 : PS6_OT_Warning**

Power supply internal temperature has reached warning threshold. Over temperature fault is possibility to occur if condition not relieved.

Severity

Warning

Serviceable

Automatically notify support

User Response

Complete the following steps:

1. Make sure that there is no obstruction blocking power supplies and system fans' air way.
2. Make sure that power supplies does not have any fault condition.
3. Make sure that room temperature is maintained at required level.
4. Make sure that all fan modules are installed and operating properly.
5. Make sure that power supplies fans are running with higher speed than system fan.
6. If condition persists after above inspection, reseal power supply.
7. If OT warning continues to present after power supply reseal, replace power supply.

- **99 : PS6_No_Present**

Power supply was removed from chassis.

Severity

Info

Serviceable

Automatically notify support

User Response

1. No user action needed.

- **A0 : Node01_BMC_Fault**

The management device on indicated node is not responding.

Severity

Critical

Serviceable

Automatically notify support

User Response

Complete the following steps:

1. Reseat Node. If fault still persist, replace node.

- **A1 : Node02_BMC_Fault**

The management device on indicated node is not responding.

Severity

Critical

Serviceable**Automatically notify support****User Response**

Complete the following steps:

1. Reseat Node. If fault still persist, replace node.

- **A2 : Node03_BMC_Fault**

The management device on indicated node is not responding.

Severity

Critical

Serviceable**Automatically notify support****User Response**

Complete the following steps:

1. Reseat Node. If fault still persist, replace node.

- **A3 : Node04_BMC_Fault**

The management device on indicated node is not responding.

Severity

Critical

Serviceable**Automatically notify support****User Response**

Complete the following steps:

1. Reseat Node. If fault still persist, replace node.

- **A4 : Node05_BMC_Fault**

The management device on indicated node is not responding.

Severity

Critical

Serviceable**Automatically notify support****User Response**

Complete the following steps:

1. Reseat Node. If fault still persist, replace node.

- **A5 : Node06_BMC_Fault**

The management device on indicated node is not responding.

Severity

Critical

Serviceable

Automatically notify support

User Response

Complete the following steps:

1. Reseat Node. If fault still persist, replace node.

- **A6 : Node07_BMC_Fault**

The management device on indicated node is not responding.

Severity

Critical

Serviceable

Automatically notify support

User Response

Complete the following steps:

1. Reseat Node. If fault still persist, replace node.

- **A7 : Node08_BMC_Fault**

The management device on indicated node is not responding.

Severity

Critical

Serviceable

Automatically notify support

User Response

Complete the following steps:

1. Reseat Node. If fault still persist, replace node.

- **A8 : Node09_BMC_Fault**

The management device on indicated node is not responding.

Severity

Critical

Serviceable

Automatically notify support

User Response

Complete the following steps:

1. Reseat Node. If fault still persist, replace node.

- **A9 : Node10_BMC_Fault**

The management device on indicated node is not responding.

Severity

Critical

Serviceable

Automatically notify support

User Response

Complete the following steps:

1. Reseat Node. If fault still persist, replace node.

- **AA : Node11_BMC_Fault**

The management device on indicated node is not responding.

Severity

Critical

Serviceable**Automatically notify support****User Response**

Complete the following steps:

1. Reseat Node. If fault still persist, replace node.

- **AB : Node12_BMC_Fault**

The management device on indicated node is not responding.

Severity

Critical

Serviceable**Automatically notify support****User Response**

Complete the following steps:

1. Reseat Node. If fault still persist, replace node.

- **AC : PSU_Unbalance**

All installed power supplies occupy only one side of the chassis and are in diagonal to the side where all powered-on nodes occupy. An unbalance power distribution condition is likely to occur.

Severity

Critical

Serviceable**Automatically notify support****User Response**

Complete the following steps:

1. Make sure all power supplies are healthy and all 6 power supplies are installed. If less number of power supplies are installed, make sure power supply slot 1 and 2 are occupied first.

- **AD : PSU_Mismatch**

Power supplies of different ratings are installed in the same chassis.

Severity

Critical

Serviceable**Automatically notify support**

User Response

Complete the following steps:

1. Make sure that there is no mix of different rating power supplies.

- **AE : PSU_Not_Support**

This error indicates at least one non-support PSU is installed.

Severity

Critical

Serviceable**Automatically notify support****User Response**

Complete the following steps:

1. Make sure that all power supplies installed are Lenovo approved common form factor power supplies supported on this type of system.

- **AF : PSU_Policy_Loses**

Previously configured power supply redundancy policy is lost.

Severity

Warning

Serviceable**Automatically notify support****User Response**

1. Make sure that FPC USB key is installed. Check if all power supplies are installed and in healthy condition.
2. If all good, reconfigure power supply redundancy policy when needed.

- **B2 : FAN01_No_Present**

Indicated fan module is missing from fan bay or not properly installed.

Severity

Critical

Serviceable**Automatically notify support****User Response**

1. Make sure that all ten fans are installed. If all fans are confirmed to be present, reseal fan modules. If event persists after fan module reseal, replace fan modules.

- **B3 : FAN02_No_Present**

Indicated fan module is missing from fan bay or not properly installed.

Severity

Critical

Serviceable**Automatically notify support**

User Response

1. Make sure that all ten fans are installed. If all fans are confirmed to be present, reseal fan modules. If event persists after fan module reseal, replace fan modules.

- **B4 : FAN03_No_Present**

Indicated fan module is missing from fan bay or not properly installed.

Severity

Critical

Serviceable**Automatically notify support****User Response**

1. Make sure that all ten fans are installed. If all fans are confirmed to be present, reseal fan modules. If event persists after fan module reseal, replace fan modules.

- **B5 : FAN04_No_Present**

Indicated fan module is missing from fan bay or not properly installed.

Severity

Critical

Serviceable**Automatically notify support****User Response**

1. Make sure that all ten fans are installed. If all fans are confirmed to be present, reseal fan modules. If event persists after fan module reseal, replace fan modules.

- **B6 : FAN05_No_Present**

Indicated fan module is missing from fan bay or not properly installed.

Severity

Critical

Serviceable**Automatically notify support****User Response**

1. Make sure that all ten fans are installed. If all fans are confirmed to be present, reseal fan modules. If event persists after fan module reseal, replace fan modules.

- **B7 : FAN06_No_Present**

Indicated fan module is missing from fan bay or not properly installed.

Severity

Critical

Serviceable**Automatically notify support****User Response**

1. Make sure that all ten fans are installed. If all fans are confirmed to be present, reseal fan modules. If event persists after fan module reseal, replace fan modules.

- **B8 : FAN07_No_Present**

Indicated fan module is missing from fan bay or not properly installed.

Severity

Critical

Serviceable

Automatically notify support

User Response

1. Make sure that all ten fans are installed. If all fans are confirmed to be present, reseal fan modules. If event persists after fan module reseal, replace fan modules.

- **B9 : FAN08_No_Present**

Indicated fan module is missing from fan bay or not properly installed.

Severity

Critical

Serviceable

Automatically notify support

User Response

1. Make sure that all ten fans are installed. If all fans are confirmed to be present, reseal fan modules. If event persists after fan module reseal, replace fan modules.

- **BA : FAN09_No_Present**

Indicated fan module is missing from fan bay or not properly installed.

Severity

Critical

Serviceable

Automatically notify support

User Response

1. Make sure that all ten fans are installed. If all fans are confirmed to be present, reseal fan modules. If event persists after fan module reseal, replace fan modules.

- **BB : FAN10_No_Present**

Indicated fan module is missing from fan bay or not properly installed.

Severity

Critical

Serviceable

Automatically notify support

User Response

1. Make sure that all ten fans are installed. If all fans are confirmed to be present, reseal fan modules. If event persists after fan module reseal, replace fan modules.

- **BC : Zone %_FAN_FFS**

All system fans in indicated zone are running in full speed.

Severity

Warning

Serviceable

Automatically notify support

User Response

Complete the following steps:

1. Make sure that room temperature is maintained at required level.
2. Make sure that all fan modules are installed and operating properly.

- **BD : Zone %_PSU_FFS**

All power supply fans in indicated zone are running in full speed.

Severity

Warning

Serviceable

Automatically notify support

User Response

Complete the following steps:

1. Make sure that room temperature is maintained at required level.
2. Make sure that all system fan modules are installed and operating properly.
3. Make sure that all PSUs are installed and operating properly.

- **BE : Leak_Snsr1_FAULT**

For water cool related setup only, this event indicates that a leakage is detected in fan bay#1 drip tray.

Severity

Critical

Serviceable

Automatically notify support

User Response

Complete the following steps:

1. Check the drip tray first to see if there is water leakage.
2. Inspect and replace the water pipe,if there is water leakage.
3. Reseat the drip tray if there is no fluid in the tray,
4. Replace the drip tray if the event continue to be asserted after drip tray reseal.

- **BF : Leak_Snsr2_FAULT**

For water cool related setup only, this event indicates that a leakage is detected in fan bay#3 drip tray.

Severity

Critical

Serviceable

Automatically notify support

User Response

Complete the following steps:

1. Check the drip tray first to see if there is water leakage.
2. Inspect and replace the water pipe,if there is water leakage.
3. Reseat the drip tray if there is no fluid in the tray,
4. Replace the drip tray if the event continue to be asserted after drip tray reseal.

- **C0 : First_Perm_Fail**

Node pre-boot power permission is denied. Node is not allowed to turn on because chassis power might be overloaded when indicated node run in fully stressed condition.

Severity

Warning

Serviceable

Automatically notify support

User Response

Complete the following steps:

1. Make sure that the node configuration meet the power limitation of current power supply configuration.
2. Make sure that there is no mismatch of PSU nor non-supported PSU installed.

- **C1 : Failsafe_No_Perm**

Power permission retrieved from node due to node BMC not responsive for at least 7 minutes.

Severity

Warning

Serviceable

Automatically notify support

User Response

Complete the following steps:

1. Reseat node one time. If node bmc heartbeat is not blinking, replace the node.

- **C2 : Node_Reseat_User**

User performed virtual reseal operation on indicated node.

Severity

Info

Serviceable

Automatically notify support

User Response

1. No user action needed.

- **C3 : Node_Reset_User**

User performed virtual reset operation on indicated node.

Severity

Info

Serviceable**Automatically notify support****User Response**

1. No user action needed.

- **C4 : Node_No_Present**

Node is not installed in the indicated slot.

Severity

Info

Serviceable**Automatically notify support****User Response**

1. No user action needed.

- **C5 : Node_DC_OFF**

Node is turned off(DC-Off)

Severity

Info

Serviceable**Automatically notify support****User Response**

1. No user action needed.

- **C6 : Second_Perm_Fail**

Node post boot continue permission is denied. Node power on process stops at POST and node is automatically turned off(DC-OFF) after a few minutes.

Severity

Warning

Serviceable**Automatically notify support****User Response**

Complete the following steps:

1. Make sure that the node configuration meet the power limitation of current power supply configuration.
2. Make sure that there is no mismatch of PSU nor non-supported PSU installed.

- **C7 : Restore_Cap_Fail**

Previously set power capping values cannot be restored

Severity

Warning

Serviceable**Automatically notify support****User Response**

Complete the following steps:

1. Make sure that FPC USB key is installed. Check if all power supplies are properly installed and in healthy condition.
2. If all good, reconfigure power capping values when needed.

- **C8 : EPOW_OUT**

Node is notified of PSU AC lost condition. Node could enter power throttling state and performance could be affected.

Severity

Non-Recoverable

Serviceable**Automatically notify support****User Response**

Complete the following steps:

1. Make sure all power supplies power cord are properly installed. Check if AC power is stable.

- **C9 : Throttle_OUT**

Node is notified of PSU Over-current condition. Node could enter power throttling state and performance could be affected.

Severity

Non-Recoverable

Serviceable**Automatically notify support****User Response**

Complete the following steps:

1. Make sure all power supplies power cord are properly installed. Check if AC power is stable.
2. Make sure that all power supplies are in healthy condition.
3. Make sure that all nodes are properly installed and are not in fault condition.
4. Make sure that the node configuration meet the power limitation of current power supply configuration.

- **CA : Chassis_Cap_Low**

User input chassis level capping value is lower than the lowest capping value possible for this particular chassis, so the user input capping value may not be maintained.

Severity

Warning

Serviceable**Automatically notify support****User Response**

1. Set capping value within suggested range.

- **CB : Node_Cap_Low**

User input node level capping value is lower than the lowest capping value possible for this particular node, so the user input capping value may not be maintained.

Severity

Warning

Serviceable

Automatically notify support

User Response

1. Set capping value within suggested range.

- **CC : USB Key Missing**

FPC detects that the onboard USB device is broken or not installed.

Severity

Critical

Serviceable

Automatically notify support

User Response

Complete the following steps:

1. Remove FPC and check if embedded USB key is installed.
2. If not installed, install Lenovo USB key shipped with FPC.
3. If installed, reseal FPC one time. Replace the USB key if problem persists.
4. Replace FPC if problem persists after USB key is replaced.

- **CD : Node_Reseat_FPC**

When node BMC was not responsive for at least 7 minutes, failsafe is triggered. Node was resealed to recover BMC function.

Severity

Critical

Serviceable

Automatically notify support

User Response

Complete the following steps:

1. Reseat node one time. If node bmc heartbeat is not blinking, replace the node.

- **CE : Hi_PCI_NOACSTIC**

Acoustic mode is disabled due to high power or thermal demanding PCI card is installed on nodes.

Severity

Warning

Serviceable

Automatically notify support

User Response

1. No user action needed.

- **CF : Node %_Hi_PCI_Card**

High power or thermal demanding PCI card is installed in this node. To maintain enough air flow for this node, chassis acoustic mode cannot be applied.

Severity

Warning

Serviceable

Automatically notify support

User Response

1. No user action needed.

- **D0 : Chassis_No_PermF1**

Power permission is denied for the whole chassis due to PSU mismatch, PSU not supported, or 1300w PSU running with 110v AC conditions.

Severity

Warning

Serviceable

Automatically notify support

User Response

1. Make sure that there is no mix of PSUs, no non-supported PSU installed, nor 1300w PSUs connected to 110v AC outlet.

- **D1 : Nodes_Power_2Big**

Sum of all running nodes' maximum power consumption is larger than power bank provided by PSUs. System could enter overloading condition.

Severity

Warning

Serviceable

Automatically notify support

User Response

1. Make sure all power supplies power cord are properly installed. Check if AC power is stable.
2. Make sure that all power supplies are in healthy condition.
3. Make sure that the node configuration meet the power limitation of current power supply configuration.

- **D2 : Throttle_OUT_FPC**

All nodes throttled due to PSU unbalance or OT warning conditions.

Severity

Warning

Serviceable

Automatically notify support

User Response

1. Make sure all power supplies power cord are properly installed. Check if AC power is stable.
2. Make sure that all power supplies are in healthy condition and there is no unbalanced configuration.
3. Check event log for PS#_OT_Warning or PSU_Unbalance entry. Follow the user action of found event to correct fault condition.

• D3 : FPC_REBOOT

FPC was manually rebooted with hardware reset button, IPMI warm reboot command, or FPC web operation.

Severity

Info

Serviceable**Automatically notify support****User Response**

1. No user action needed.

• D4 : USER_RST_DEFAULT

FPC network related settings were manually cleared and reset to out-of-factory default with one of the following actions: 1)Press hardware reset button for more than 4s. 2)Click on the "Reset to Default" button on the FPC web 'Chassis Rear Overview' page. 3)IPMI command to FPC (ipmitool -H IP -U USERID -P PASSWORD -I lanplus raw 0x32 0xAD).

Severity

Info

Serviceable**Automatically notify support****User Response**

1. No user action needed.

• D5 : FPC_POWER_ON

This event assertion indicates that the chassis was ac cycled, FPC was rebooted, or FPC was hot-swapped.

Severity

Info

Serviceable**Automatically notify support****User Response**

1. No user action needed.

• D6 : PS_0_OUTPUT_FAIL

PSU failed to enter zero output mode after 3 re-tries.

Severity

Info

Serviceable**Automatically notify support****User Response**

1. No user action needed.

- **E0 : LeakSnr1_Missing**

For water cool related setup only, this event indicates that drip tray is missing from fan bay#1.

Severity

Critical

Serviceable**Automatically notify support****User Response**

Complete the following steps:

1. Ensure both drip trays are installed in fan bay1 and 3 of the chassis.
2. Ensure all connecting cable are plugged properly if trays are installed.
3. Replace the drip tray if the event continue to be asserted when tray is already confirmed to be installed.

- **E1 : LeakSnr2_Missing**

For water cool related setup only, this event indicates that drip tray is missing from fan bay#3.

Severity

Critical

Serviceable**Automatically notify support****User Response**

Complete the following steps:

1. Ensure both drip trays are installed in fan bay1 and 3 of the chassis.
2. Ensure all connecting cable are plugged properly if trays are installed.
3. Replace the drip tray if the event continue to be asserted when tray is already confirmed to be installed.

Appendix B. Getting help and technical assistance

If you need help, service, or technical assistance or just want more information about Lenovo products, you will find a wide variety of sources available to assist you.

Use this information to obtain additional information about Lenovo and Lenovo products, determine what to do if you experience a problem with your Lenovo system or optional device, and determine whom to call for service, if it is necessary.

Before you call

Before you call, make sure that you have taken these steps to try to solve the problem yourself.

If you believe that you require Lenovo to perform warranty service on your Lenovo product, the Lenovo service technicians will be able to assist you more efficiently if you prepare before you call.

- Check all cables to make sure that they are connected.
- Check the power switches to make sure that the system and any optional devices are turned on.
- Check for updated software, firmware, and operating-system device drivers for your Lenovo product. The Lenovo Warranty terms and conditions state that you, the owner of the Lenovo product, are responsible for maintaining and updating all software and firmware for the product (unless it is covered by an additional maintenance contract). Your Lenovo service technician will request that you upgrade your software and firmware if the problem has a documented solution within a software upgrade.
- If you have installed new hardware or software in your environment, check <http://static.lenovo.com/us/en/serverproven/index.shtml> to make sure that the hardware and software is supported by your Lenovo product.
- Go to <http://support.lenovo.com> to check for information to help you solve the problem.
- Gather the following information to provide to Lenovo Support. This data will help Lenovo Support quickly provide a solution to your problem and ensure that you receive the level of service for which you might have contracted.
 - Hardware and Software Maintenance agreement contract numbers, if applicable
 - Machine type number (Lenovo 4-digit machine identifier)
 - Model number
 - Serial number
 - Current system UEFI and firmware levels
 - Other pertinent information such as error messages and logs
- Go to http://www.ibm.com/support/entry/portal/Open_service_request to submit an Electronic Service Request. Submitting an Electronic Service Request will start the process of determining a solution to your problem by making the pertinent information available to Lenovo Support quickly and efficiently. Lenovo service technicians can start working on your solution as soon as you have completed and submitted an Electronic Service Request.

You can solve many problems without outside assistance by following the troubleshooting procedures that Lenovo provides in the online help or in the documentation that is provided with your Lenovo product. The documentation that comes with Lenovo systems also describes the diagnostic tests that you can perform. Most systems, operating systems, and programs come with documentation that contains troubleshooting procedures and explanations of error messages and error codes. If you suspect a software problem, see the documentation for the operating system or program.

Using the documentation

Information about your Lenovo system and preinstalled software, if any, or optional device is available in the documentation that comes with the product. That documentation can include printed documents, online documents, readme files, and help files.

See the troubleshooting information in your system documentation for instructions for using the diagnostic programs. The troubleshooting information or the diagnostic programs might tell you that you need additional or updated device drivers or other software. Lenovo maintains pages on the World Wide Web where you can get the latest technical information and download device drivers and updates. To access these pages, go to <http://support.lenovo.com>.

Getting help and information from the World Wide Web

Up-to-date information about Lenovo products and support is available on the World Wide Web.

On the World Wide Web, up-to-date information about Lenovo systems, optional devices, services, and support is available at <http://support.lenovo.com>. Lenovo System x information is at <http://systemx.lenovofiles.com/help/index.jsp>. Lenovo BladeCenter information is at http://bladecenter.lenovofiles.com/help/topic/com.lenovo.bladecenter.common.nav.doc/bladecenter_converged_welcome_page.html. Lenovo IntelliStation information is at <https://www3.lenovo.com/us/en/landingpage/workstations/>.

How to send DSA data

Use the Enhanced Customer Data Repository to send diagnostic data.

Before you send diagnostic data, read the terms of use at <http://www.ibm.com/de/support/ecurep/terms.html>.

You can use any of the following methods to send diagnostic data to Lenovo:

- **Standard upload:** http://www.ibm.com/de/support/ecurep/send_http.html
- **Standard upload with the system serial number:** http://www.ecurep.ibm.com/app/upload_hw
- **Secure upload:** http://www.ibm.com/de/support/ecurep/send_http.html#secure
- **Secure upload with the system serial number:** https://www.ecurep.ibm.com/app/upload_hw

Creating a personalized support web page

You can create a personalized support web page by identifying Lenovo products that are of interest to you.

To create a personalized support web page, go to <https://support.lenovo.com>. From this personalized page, you can subscribe to weekly email notifications about new technical documents, search for information and downloads, and access various administrative services.

Software service and support

Through the support line, you can get telephone assistance, for a fee, with usage, configuration, and software problems with your Lenovo products.

For information about which products are supported by Support Line in your country or region, see <http://www.ibm.com/services/supline/products>.

For more information about Support Line and other Lenovo services, see <http://www.ibm.com/services> or see <http://www.ibm.com/planetwide> for support telephone numbers. In the U.S. and Canada, call 1-800-Lenovo-SERV (1-800-426-7378).

Hardware service and support

You can receive hardware service through your Lenovo reseller or Lenovo Services.

To locate a reseller authorized by Lenovo to provide warranty service, go to <http://www.ibm.com/partnerworld> and click **Find Business Partners** on the right side of the page. For Lenovo support telephone numbers, see <http://www.ibm.com/planetwide>. In the U.S. and Canada, call 1-800-Lenovo-SERV (1-800-426-7378).

In the U.S. and Canada, hardware service and support is available 24 hours a day, 7 days a week. In the U.K., these services are available Monday through Friday, from 9 a.m. to 6 p.m.

Taiwan product service

Use this information to contact product service for Taiwan.

委製商/進口商名稱: 台灣聯想環球科技股份有限公司
進口商地址: 台北市南港區三重路 66 號 8 樓
進口商電話: 0800-000-702

委製商/進口商名稱: 台灣聯想環球科技股份有限公司
進口商地址: 台北市南港區三重路 66 號 8 樓
進口商電話: 0800-000-702

Appendix C. Notices

This information was developed for products and services offered in the U.S.A.

IBM may not offer the products, services, or features discussed in this document in other countries. Consult your local IBM representative for information on the products and services currently available in your area. Any reference to an IBM product, program, or service is not intended to state or imply that only that IBM product, program, or service may be used. Any functionally equivalent product, program, or service that does not infringe any IBM intellectual property right may be used instead. However, it is the user's responsibility to evaluate and verify the operation of any non-IBM product, program, or service.

IBM may have patents or pending patent applications covering subject matter described in this document. The furnishing of this document does not give you any license to these patents. You can send license inquiries, in writing, to:

*IBM Director of Licensing
IBM Corporation
North Castle Drive
Armonk, NY 10504-1785
U.S.A.*

INTERNATIONAL BUSINESS MACHINES CORPORATION PROVIDES THIS PUBLICATION "AS IS" WITHOUT WARRANTY OF ANY KIND, EITHER EXPRESS OR IMPLIED, INCLUDING, BUT NOT LIMITED TO, THE IMPLIED WARRANTIES OF NON-INFRINGEMENT, MERCHANTABILITY OR FITNESS FOR A PARTICULAR PURPOSE. Some states do not allow disclaimer of express or implied warranties in certain transactions, therefore, this statement may not apply to you.

This information could include technical inaccuracies or typographical errors. Changes are periodically made to the information herein; these changes will be incorporated in new editions of the publication. IBM may make improvements and/or changes in the product(s) and/or the program(s) described in this publication at any time without notice.

Any references in this information to non-IBM websites are provided for convenience only and do not in any manner serve as an endorsement of those websites. The materials at those websites are not part of the materials for this IBM product, and use of those websites is at your own risk.

IBM may use or distribute any of the information you supply in any way it believes appropriate without incurring any obligation to you.

Trademarks

IBM, the IBM logo, and [ibm.com](http://www.ibm.com) are trademarks of International Business Machines Corp., registered in many jurisdictions worldwide. Other product and service names might be trademarks of IBM or other companies.

A current list of IBM trademarks is available on the web at <http://www.ibm.com/legal/us/en/copytrade.shtml>.

Adobe and PostScript are either registered trademarks or trademarks of Adobe Systems Incorporated in the United States and/or other countries.

Cell Broadband Engine is a trademark of Sony Computer Entertainment, Inc., in the United States, other countries, or both and is used under license therefrom.

Intel, Intel Xeon, Itanium, and Pentium are trademarks or registered trademarks of Intel Corporation or its subsidiaries in the United States and other countries.

Java and all Java-based trademarks and logos are trademarks or registered trademarks of Oracle and/or its affiliates.

Linux is a registered trademark of Linus Torvalds in the United States, other countries, or both.

Microsoft, Windows, and Windows NT are trademarks of Microsoft Corporation in the United States, other countries, or both.

UNIX is a registered trademark of The Open Group in the United States and other countries.

Important notes

Processor speed indicates the internal clock speed of the microprocessor; other factors also affect application performance.

CD or DVD drive speed is the variable read rate. Actual speeds vary and are often less than the possible maximum.

When referring to processor storage, real and virtual storage, or channel volume, KB stands for 1024 bytes, MB stands for 1,048,576 bytes, and GB stands for 1,073,741,824 bytes.

When referring to hard disk drive capacity or communications volume, MB stands for 1,000,000 bytes, and GB stands for 1,000,000,000 bytes. Total user-accessible capacity can vary depending on operating environments.

Maximum internal hard disk drive capacities assume the replacement of any standard hard disk drives and population of all hard disk drive bays with the largest currently supported drives that are available from IBM.

Maximum memory might require replacement of the standard memory with an optional memory module.

Each solid-state memory cell has an intrinsic, finite number of write cycles that the cell can incur. Therefore, a solid-state device has a maximum number of write cycles that it can be subjected to, expressed as “total bytes written” (TBW). A device that has exceeded this limit might fail to respond to system-generated commands or might be incapable of being written to. IBM is not responsible for replacement of a device that has exceeded its maximum guaranteed number of program/erase cycles, as documented in the Official Published Specifications for the device.

IBM makes no representation or warranties regarding non-IBM products and services that are ServerProven, including but not limited to the implied warranties of merchantability and fitness for a particular purpose. These products are offered and warranted solely by third parties.

IBM makes no representations or warranties with respect to non-IBM products. Support (if any) for the non-IBM products is provided by the third party, not IBM.

Some software might differ from its retail version (if available) and might not include user manuals or all program functionality.

Recycling information

Lenovo encourages owners of information technology (IT) equipment to responsibly recycle their equipment when it is no longer needed. Lenovo offers a variety of programs and services to assist equipment owners in

recycling their IT products. For information on recycling Lenovo products, go to: <http://www.lenovo.com/recycling>.



US & Canada Only



US & Canada Only

Particulate contamination

Attention: Airborne particulates (including metal flakes or particles) and reactive gases acting alone or in combination with other environmental factors such as humidity or temperature might pose a risk to the device that is described in this document.

Risks that are posed by the presence of excessive particulate levels or concentrations of harmful gases include damage that might cause the device to malfunction or cease functioning altogether. This specification sets forth limits for particulates and gases that are intended to avoid such damage. The limits must not be viewed or used as definitive limits, because numerous other factors, such as temperature or moisture content of the air, can influence the impact of particulates or environmental corrosives and gaseous contaminant transfer. In the absence of specific limits that are set forth in this document, you must implement practices that maintain particulate and gas levels that are consistent with the protection of human health and safety. If IBM determines that the levels of particulates or gases in your environment have caused damage to the device, IBM may condition provision of repair or replacement of devices or parts on implementation of appropriate remedial measures to mitigate such environmental contamination. Implementation of such remedial measures is a customer responsibility.

Table 12. Limits for particulates and gases

| Contaminant | Limits |
|---|---|
| Particulate | <ul style="list-style-type: none"> The room air must be continuously filtered with 40% atmospheric dust spot efficiency (MERV 9) according to ASHRAE Standard 52.2¹. Air that enters a data center must be filtered to 99.97% efficiency or greater, using high-efficiency particulate air (HEPA) filters that meet MIL-STD-282. The deliquescent relative humidity of the particulate contamination must be more than 60%². The room must be free of conductive contamination such as zinc whiskers. |
| Gaseous | <ul style="list-style-type: none"> Copper: Class G1 as per ANSI/ISA 71.04-1985³ Silver: Corrosion rate of less than 300 Å in 30 days |
| <p>¹ ASHRAE 52.2-2008 - <i>Method of Testing General Ventilation Air-Cleaning Devices for Removal Efficiency by Particle Size</i>. Atlanta: American Society of Heating, Refrigerating and Air-Conditioning Engineers, Inc.</p> <p>² The deliquescent relative humidity of particulate contamination is the relative humidity at which the dust absorbs enough water to become wet and promote ionic conduction.</p> <p>³ ANSI/ISA-71.04-1985. <i>Environmental conditions for process measurement and control systems: Airborne contaminants</i>. Instrument Society of America, Research Triangle Park, North Carolina, U.S.A.</p> | |

Telecommunication regulatory statement

This product may not be certified in your country for connection by any means whatsoever to interfaces of public telecommunications networks. Further certification may be required by law prior to making any such connection. Contact an IBM representative or reseller for any questions.

Electronic emission notices

When you attach a monitor to the equipment, you must use the designated monitor cable and any interference suppression devices that are supplied with the monitor.

Federal Communications Commission (FCC) statement

Note: This equipment has been tested and found to comply with the limits for a Class A digital device, pursuant to Part 15 of the FCC Rules. These limits are designed to provide reasonable protection against harmful interference when the equipment is operated in a commercial environment. This equipment generates, uses, and can radiate radio frequency energy and, if not installed and used in accordance with the instruction manual, may cause harmful interference to radio communications. Operation of this equipment in a residential area is likely to cause harmful interference, in which case the user will be required to correct the interference at his own expense.

Properly shielded and grounded cables and connectors must be used in order to meet FCC emission limits. IBM is not responsible for any radio or television interference caused by using other than recommended cables and connectors or by unauthorized changes or modifications to this equipment. Unauthorized changes or modifications could void the user's authority to operate the equipment.

This device complies with Part 15 of the FCC Rules. Operation is subject to the following two conditions: (1) this device may not cause harmful interference, and (2) this device must accept any interference received, including interference that might cause undesired operation.

Industry Canada Class A emission compliance statement

This Class A digital apparatus complies with Canadian ICES-003.

Avis de conformité à la réglementation d'Industrie Canada

Cet appareil numérique de la classe A est conforme à la norme NMB-003 du Canada.

Australia and New Zealand Class A statement

Attention: This is a Class A product. In a domestic environment this product may cause radio interference in which case the user may be required to take adequate measures.

European Union EMC Directive conformance statement

This product is in conformity with the protection requirements of EU Council Directive 2014/30/EU on the approximation of the laws of the Member States relating to electromagnetic compatibility. Lenovo cannot accept responsibility for any failure to satisfy the protection requirements resulting from a non-recommended modification of the product, including the installation of option cards from other manufacturers.

This product has been tested and found to comply with the limits for Class A equipment according to European Standards harmonized in the Directives in compliance. The limits for Class A equipment were derived for commercial and industrial environments to provide reasonable protection against interference with licensed communication equipment.

Lenovo, Einsteinova 21, 851 01 Bratislava, Slovakia



Warning: This is a Class A product. In a domestic environment this product may cause radio interference in which case the user may be required to take adequate measures.

Germany Class A statement

Deutschsprachiger EU Hinweis: Hinweis für Geräte der Klasse A EU-Richtlinie zur Elektromagnetischen Verträglichkeit

Deutschsprachiger EU Hinweis: Hinweis für Geräte der Klasse A EU-Richtlinie zur Elektromagnetischen Verträglichkeit Dieses Produkt entspricht den Schutzanforderungen der EU-Richtlinie 2014/30/EU (früher 2004/108/EC) zur Angleichung der Rechtsvorschriften über die elektromagnetische Verträglichkeit in den EU-Mitgliedsstaaten und hält die Grenzwerte der Klasse A der Norm gemäß Richtlinie.

Um dieses sicherzustellen, sind die Geräte wie in den Handbüchern beschrieben zu installieren und zu betreiben. Des Weiteren dürfen auch nur von der Lenovo empfohlene Kabel angeschlossen werden. Lenovo übernimmt keine Verantwortung für die Einhaltung der Schutzanforderungen, wenn das Produkt ohne Zustimmung der Lenovo verändert bzw. wenn Erweiterungskomponenten von Fremdherstellern ohne Empfehlung der Lenovo gesteckt/eingebaut werden.

Deutschland:

Einhaltung des Gesetzes über die elektromagnetische Verträglichkeit von Betriebsmitteln Dieses Produkt entspricht dem „Gesetz über die elektromagnetische Verträglichkeit von Betriebsmitteln“ EMVG (früher „Gesetz über die elektromagnetische Verträglichkeit von Geräten“). Dies ist die Umsetzung der EU-Richtlinie 2014/30/EU (früher 2004/108/EC) in der Bundesrepublik Deutschland.

Zulassungsbescheinigung laut dem Deutschen Gesetz über die elektromagnetische Verträglichkeit von Betriebsmitteln, EMVG vom 20. Juli 2007 (früher Gesetz über die elektromagnetische Verträglichkeit von Geräten), bzw. der EMV EU Richtlinie 2014/30/EU (früher 2004/108/EC), für Geräte der Klasse A.

Dieses Gerät ist berechtigt, in Übereinstimmung mit dem Deutschen EMVG das EG-Konformitätszeichen - CE - zu führen. Verantwortlich für die Konformitätserklärung nach Paragraph 5 des EMVG ist die Lenovo (Deutschland) GmbH, Meitnerstr. 9, D-70563 Stuttgart.

Informationen in Hinsicht EMVG Paragraph 4 Abs. (1) 4: **Das Gerät erfüllt die Schutzanforderungen nach EN 55024 und EN 55022 Klasse A.**

Nach der EN 55022: „Dies ist eine Einrichtung der Klasse A. Diese Einrichtung kann im Wohnbereich Funkstörungen verursachen; in diesem Fall kann vom Betreiber verlangt werden, angemessene Maßnahmen durchzuführen und dafür aufzukommen.“

Nach dem EMVG: „Geräte dürfen an Orten, für die sie nicht ausreichend entstört sind, nur mit besonderer Genehmigung des Bundesministers für Post und Telekommunikation oder des Bundesamtes für Post und Telekommunikation betrieben werden. Die Genehmigung wird erteilt, wenn keine elektromagnetischen Störungen zu erwarten sind.“ (Auszug aus dem EMVG, Paragraph 3, Abs. 4). Dieses Genehmigungsverfahren ist nach Paragraph 9 EMVG in Verbindung mit der entsprechenden Kostenverordnung (Amtsblatt 14/93) kostenpflichtig.

Anmerkung: Um die Einhaltung des EMVG sicherzustellen sind die Geräte, wie in den Handbüchern angegeben, zu installieren und zu betreiben.

Japanese electromagnetic compatibility statements

Japan VCCI Class A statement

この装置は、クラスA情報技術装置です。この装置を家庭環境で使用すると電波障害を引き起こすことがあります。この場合には使用者が適切な対策を講ずるよう要求されることがあります。 V C C I - A

This is a Class A product based on the standard of the Voluntary Control Council for Interference (VCCI). If this equipment is used in a domestic environment, radio interference may occur, in which case the user may be required to take corrective actions.

Japanese Electrical Appliance and Material Safety Law statement (for detachable AC power cord)

本製品およびオプションに電源コード・セットが付属する場合は、それぞれ専用のものになっていますので他の電気機器には使用しないでください。

JEITA harmonics guideline - Japanese Statement for AC power consumption (W)

定格入力電力表示
(社) 電子情報技術参照委員会 家電・汎用品高調波抑制対策ガイドライン
実行計画書に基づく定格入力電力値: W
お手持ちのユニットの定格入力電力値(W)はユニットの電源装置に貼付されている電源仕様ラベルをご参照下さい

JEITA harmonics guideline - Japanese Statement of Compliance for Products Less than or Equal to 20A per phase

JEITA 高調波電流抑制対策適合品表示 (JEITA harmonics statements– Japan)
定格電流が 20A/相以下の機器 (For products where input current is less than or equal to 20A per phase)

日本の定格電流が 20A/相 以下の機器に対する高調波電流規制高調波電流規格
JIS C 61000-3-2 適合品

JEITA harmonics guideline - Japanese Statement of Compliance for Products More than 20A

定格電流が 20A/相を超える機器 (For products where input current is less than 20A/Phase of one PSU, but total system power is over 20A/Phase)

本製品は、1相当たり20Aを超える機器ですが、個々のユニットが「高調波電流規格 JIS C 61000-3-2適合品」であり、
本製品はその組み合わせであるため、「高調波電流規格 JIS C 61000-3-2適合品」としてあります

Korea Communications Commission (KCC) statement

이 기기는 업무용(A급)으로 전자파적합기기로
서 판매자 또는 사용자는 이 점을 주의하시기
바라며, 가정외의 지역에서 사용하는 것을 목
적으로 합니다.

This is electromagnetic wave compatibility equipment for business (Type A). Sellers and users need to pay attention to it. This is for any areas other than home.

Russia Electromagnetic Interference (EMI) Class A statement

ВНИМАНИЕ!

Настоящее изделие относится к оборудованию класса А. При использовании в бытовой обстановке это оборудование может нарушать функционирование других технических средств в результате создаваемых промышленных радиопомех. В этом случае от пользователя может потребоваться принятие адекватных мер.

People's Republic of China Class A electronic emission statement

声 明

此为 A 级产品。在生活环境中，
该产品可能会造成无线电干扰。
在这种情况下，可能需要用户对其
干扰采取切实可行的措施。

Taiwan Class A compliance statement

警告使用者：
這是甲類的資訊產品，在
居住的環境中使用時，可
能會造成射頻干擾，在這
種情況下，使用者會被要
求採取某些適當的對策。

Taiwan BSMI RoHS declaration

| 單元 Unit | 限用物質及其化學符號 Restricted substances and its chemical symbols | | | | | |
|--|--|------------------|------------------|--|--|--|
| | 鉛Lead (Pb) | 汞Mercury (Hg) | 鎘Cadmium (Cd) | 六價鉻 Hexavalent chromium (Cr ⁶⁺) | 多溴聯苯 Polybrominated biphenyls (PBB) | 多溴二苯醚 Polybrominated diphenyl ethers (PBDE) |
| 機架 | ○ | ○ | ○ | ○ | ○ | ○ |
| 外部蓋板 | ○ | ○ | ○ | ○ | ○ | ○ |
| 機械組套件 | - | ○ | ○ | ○ | ○ | ○ |
| 空氣傳動設備 | - | ○ | ○ | ○ | ○ | ○ |
| 冷卻組套件 | - | ○ | ○ | ○ | ○ | ○ |
| 內存模塊 | - | ○ | ○ | ○ | ○ | ○ |
| 處理器模塊 | - | ○ | ○ | ○ | ○ | ○ |
| 鍵盤 | - | ○ | ○ | ○ | ○ | ○ |
| 調製解調器 | - | ○ | ○ | ○ | ○ | ○ |
| 監視器 | - | ○ | ○ | ○ | ○ | ○ |
| 滑鼠 | - | ○ | ○ | ○ | ○ | ○ |
| 電纜組套件 | - | ○ | ○ | ○ | ○ | ○ |
| 電源 | - | ○ | ○ | ○ | ○ | ○ |
| 儲備設備 | - | ○ | ○ | ○ | ○ | ○ |
| 電池匣組套件 | - | ○ | ○ | ○ | ○ | ○ |
| 有mech的電路卡 | - | ○ | ○ | ○ | ○ | ○ |
| 無mech的電路卡 | - | ○ | ○ | ○ | ○ | ○ |
| 雷射器 | - | ○ | ○ | ○ | ○ | ○ |
| <p>備考1. “超出0.1 wt %” 及 “超出0.01 wt %” 係指限用物質之百分比含量超出百分比含量基準值。 Note1: “exceeding 0.1wt%” and “exceeding 0.01 wt%” indicate that the percentage content of the restricted substance exceeds the reference percentage value of presence condition.</p> <p>備考2. “○” 係指該項限用物質之百分比含量未超出百分比含量基準值。 Note2: “○” indicates that the percentage content of the restricted substance does not exceed the percentage of reference value of presence.</p> <p>備考3. “-” 係指該項限用物質為排除項目。 Note3: The “-” indicates that the restricted substance corresponds to the exemption.</p> | | | | | | |

Appendix D. German Ordinance for Work gloss statement

The product is not suitable for use with visual display work place devices according to clause 2 of the German Ordinance for Work with Visual Display Units.

Das Produkt ist nicht für den Einsatz an Bildschirmarbeitsplätzen im Sinne § 2 der Bildschirmarbeitsverordnung geeignet.

Index

A

- AC power supply
 - installing 47
 - removing 46
- assistance, getting 123
- attention notices 5
- Australia Class A statement 130

B

- battery
 - removing 33
 - replacing 35
- Brocade documentation 5

C

- Canada Class A electronic emission statement 130
- caution statements 5
- chassis components 8
- China Class A electronic emission statement 133
- Class A electronic emission notice 130
- component
 - returning 25
- components
 - chassis 8
 - Compute nodes 10
 - fan module 14
 - fan power control 11
 - power supply 13
 - server 17
- compute node 10
 - installing 28
 - removing 27
- connectors, hot-pluggable 1
- contamination, particulate and gaseous 129
- Controls and indicators
 - compute node 10
- cooling 6
- creating a personalized support web page 124
- custom support web page 124

D

- danger statements 5
- device, returning 25
- devices, static-sensitive
 - handling guidelines 25
- documentation
 - Documentation Browser 3
 - Documentation CD 3
 - using 124
- documentation cd 3
- documentation, Brocade 5
- documentation, updated
 - finding 4
- DSA, sending data 124

E

- electrical equipment, servicing v
- electrical input 6

- electronic emission Class A notice 130
- environment 6–7
- error codes and messages
 - Fan power control (FPC) 83
- European Union EMC Directive conformance statement 130
- expansion capabilities 1

F

- fan module
 - installing 30
 - overview 14
 - removing 29
- fan power control 63, 65
 - bay 11
 - indicators and controls 12
 - installing 32
 - overview 11
 - removing 31
- Fan power control
 - error codes 83
- fan power control web interface
 - resetting 63
 - starting 63
- FCC Class A notice 130
- features 1, 6
- finding
 - updated documentation 4
- firmware updates 23
- FPC
 - error codes 83
- front view
 - NeXtScale n1200 Enclosure 9
- FRUs, replacement 55

G

- gaseous contamination 129
- German Ordinance for Work gloss statement 135
- Germany Class A statement 131
- guidelines
 - options installation 23
 - servicing electrical equipment v
 - system reliability 24
 - trained service technicians iv

H

- handling static-sensitive devices 25
- hardware requirements 3
- hardware service and support telephone numbers 125
- heat output 6–7
- help
 - from the World Wide Web 124
 - from World Wide Web 124
 - sending diagnostic data 124
 - sources of 123
- hot-pluggable connectors 1
- hot-swap DC power supply
 - replacing 41
- humidity 7

I

- important notices 5, 128
- indicators and controls
 - fan 14
 - fan power control 12
 - power supply 13
- information center 124
- inspecting for unsafe conditions iv
- installation guidelines 23
- installing
 - AC power supply 47
 - compute node 28
 - fan module 30
 - fan power control 32
 - midplane 58

J

- Japanese electromagnetic compatibility statements 132

K

- Korea Class A electronic emission statement 133

L

- LEDs
 - compute node 10
 - fan 14
 - fan power control 12
 - power supply 13

M

- messages, error
 - FPC 83
- midplane
 - installing 58
 - removing 55
- module bays 6

N

- New Zealand Class A statement 130
- NeXtScale n1200 Enclosure Types 5456
 - connectors, hot-pluggable 1
 - expansion capabilities 1
 - features 1
 - hot-pluggable connectors 1
 - overview 1
 - X-architecture technology 1
- node bays
 - specifications 6
- notes 5
- notes, important 128
- notices 127
 - electronic emission 130
 - FCC, Class A 130
- notices and statements 5

O

- online publications 4
- operating system 3
- overview 10

P

- particulate contamination 129
- parts listing 17
- parts, structural 20
- People's Republic of China Class A electronic emission statement 133
- power
 - specifications 6
- power cords 20
- power supplies 6
- power supply
 - overview 13
- product service, Taiwan 125
- publications, Brocade 5

R

- rear view
 - NeXtScale n1200 Enclosure 10
- removing
 - AC power supply 46
 - battery 33
 - components 23
 - compute node 27
 - fan module 29
 - fan power control 31
 - hot-swap DC power supply 38
 - midplane 55
 - shipping bracket 25
- Replaceable server components 17
- replacing
 - battery 35
 - components 23
 - FRUs 55
 - hot-swap DC power supply 41
 - shipping bracket 26
 - structural parts 25
 - Tier 1 CRUs 27
 - Tier 1 CRUs, replacement 27
- requirements
 - hardware 3
 - software 3
- resetting the fan power control web interface 63
- returning a device or component 25
- Russia Class A electronic emission statement 133

S

- safety iii
- Safety Information 5
- safety statements iii, vi
- security features: 6
- sending diagnostic data 124
- server components 17
- serverproven 23
- service and support
 - before you call 123
 - hardware 125
 - software 124
- servicing electrical equipment v
- shipping bracket
 - removing 25
 - replacing 26
- size 6
- software requirements 3
- software service and support telephone numbers 124
- specifications 6
- starting the fan power control web interface 63
- statements and notices 5
- static-sensitive devices
 - handling guidelines 25

structural parts 20
support web page, custom 124
system reliability guidelines 24
system specifications 6

T

Taiwan BSMI RoHS declaration 134
Taiwan Class A electronic emission statement 133
Taiwan product service 125
telecommunication regulatory statement 130
telephone numbers 124–125
temperature 7
ToolsCenter for System x and BladeCenter 23
trademarks 127
trained service technicians, guidelines iv

U

United States FCC Class A notice 130
unsafe conditions, inspecting for iv
upgradeable microcode 6
USB flash drive
installing 37
removing 37

W

web interface
fan power control 63, 65
weight 6

X

X-architecture technology 1



Part Number: SP47A31686

Printed in China

(1P) P/N: SP47A31686

