

# Rack Installation Guide

---

## Friction Rail Kit Installation Guide

### Read the guidelines first

Before you install the server in a rack, read the following guidelines:

- Two or more people are required to install 2U/4U or larger devices in a rack.
- Some illustrations might differ from your server. All types of server are removed and installed in a similar manner.
- See the *User Guide* or *Maintenance Manual* for the maximum room air temperature.
- Install the server only in a rack that has perforated doors.
- Do not block any air vents, usually 150 mm (6 inches) of air space provides proper airflow.
- Plan the device installation starting from the bottom of the rack.
- Install the heaviest device in the bottom of the rack.
- Do not leave open space above or below an installed server in your rack. To help prevent damage to server components, always install a filler panel to cover the open space and to help ensure proper air circulation.
- Do not extend more than one device out of the rack at the same time.
- Do not place any objects on the top of the rack-mounted devices.
- Connect all power cords to properly wired and grounded electrical outlets.
- Do not overload the power outlet when installing multiple devices in the rack.
- Remove the rack doors and side panels to provide easier access during installation.
- Install the server in a rack that meets the following requirements:
  - Minimum depth of 70 mm (2.76 inches) between the front mounting flange and inside of the front door.
  - Minimum depth of 190 mm (7.48 inches) between the rear mounting flange and inside of the rear door.
  - The maximum distance between the front and the rear EIA flange of the rack is 810 mm (31.9 inches).
  - If you want to install the rails and a 0U PDU into the same rack, the rack must be 42U or higher.

### Safety notice



**CAUTION:**  
Make sure the rails support your server model and lift it with two people and safe practices.



The rail package contains the following items:

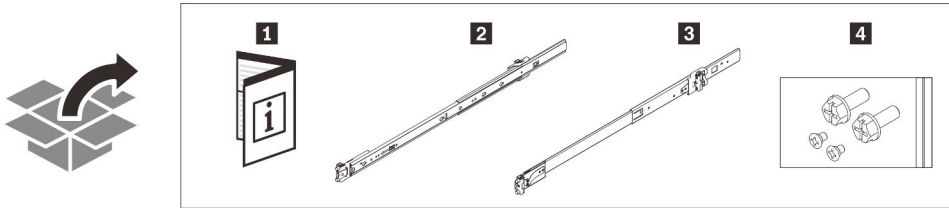

<b>1</b> Document	<b>2</b> Left rail
<b>3</b> Right rail	<b>4</b> Two M6 screws and two M3.5 screws

**Attention:** There are “L” and “R” logos marked on the front of inner rails which represent the left rail and the right rail as the following illustration. Ensure correct rails are installed to the rack accordingly.

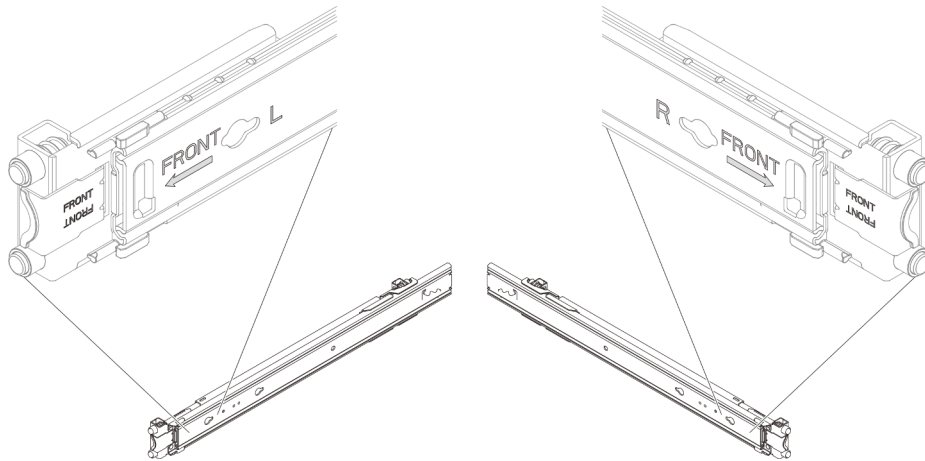

## Installation

### 1. Disengage the inner rails

Step 1. Select one of the rails and pull its inner rail outward until you see the release latch.

Step 2. Press the release latch to disengage the inner rail from the outer rail.

Step 3. Pull the inner rail out from the outer rail.

Step 4. Repeat Step 1 to Step 3 to install the other rail.

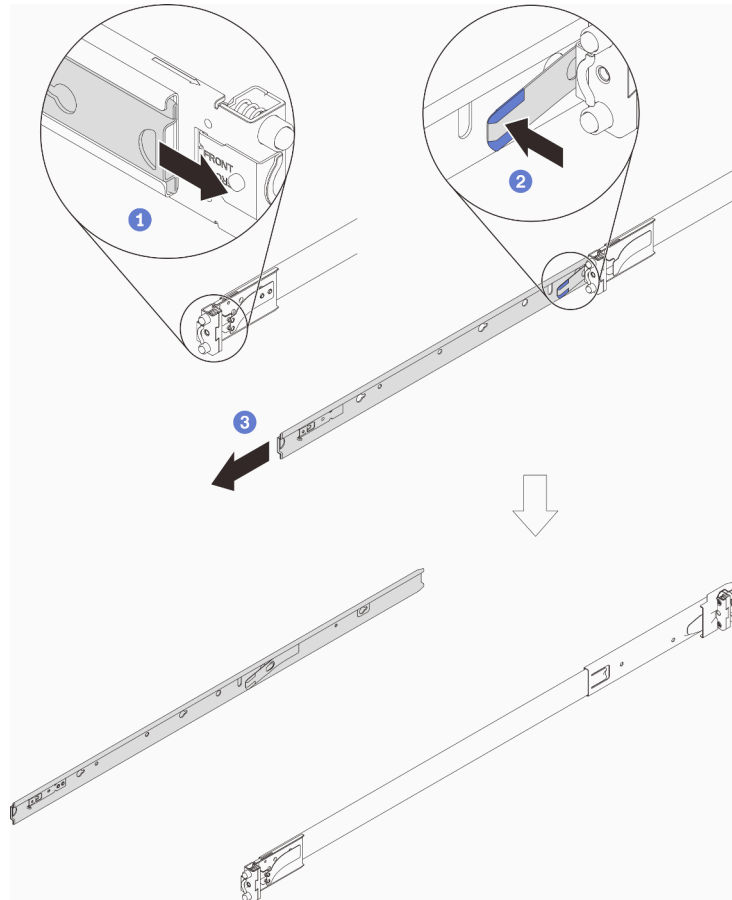

## 2. Install the inner rails on the server

**Note:** The appearance of the server and the number of the rail mounting pins on the side of the server may be different depending on the server model.

Step 1. Align the mounting holes on the inner rail with the corresponding rail mounting pins on the side of the server.

Step 2. Push the inner rail as shown until the mounting pins on the server are locked in place.

Step 3. Depending on the model, tighten one or two M3.5 screws to secure the inner rail to the server.

Step 4. Repeat Step 1 to Step 3 to install the other rail.

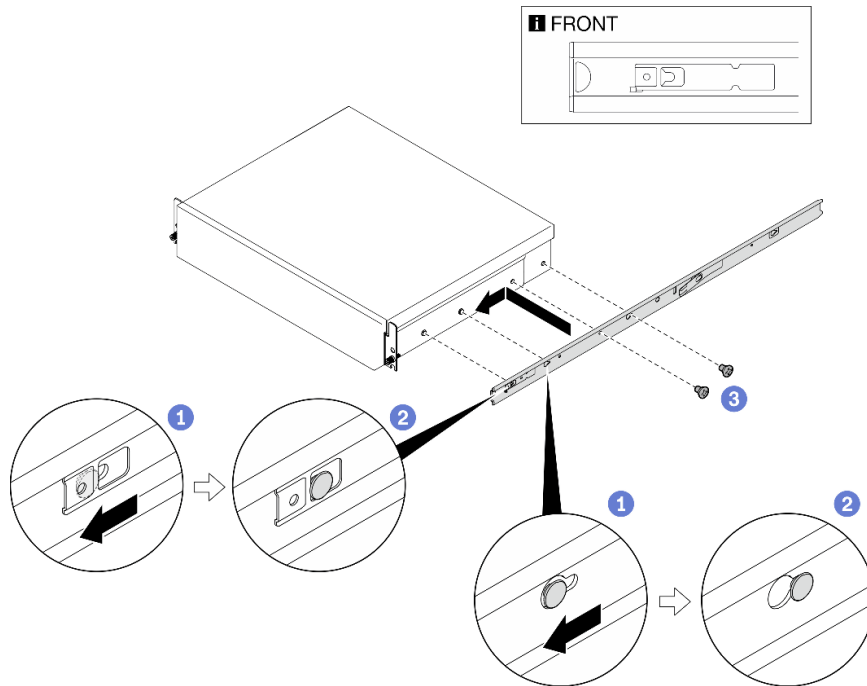

## 3. Install the outer rails to the rack

Install one of the outer rails according to the following steps. Repeat these steps on the other rail.

### Install the rear mounting bracket to the rack:

Step 1. Align the pins on the rear end of the outer rail to the holes on the rear of the rack.

Step 2. Slightly move the rail aside to hook the rear mounting bracket to the frame, and then push the outer rail outward as shown.

Step 3. Push the rail back until the pins are inserted into the corresponding holes on the rack.

Step 4. The rear end of the outer rail will be locked into place automatically.

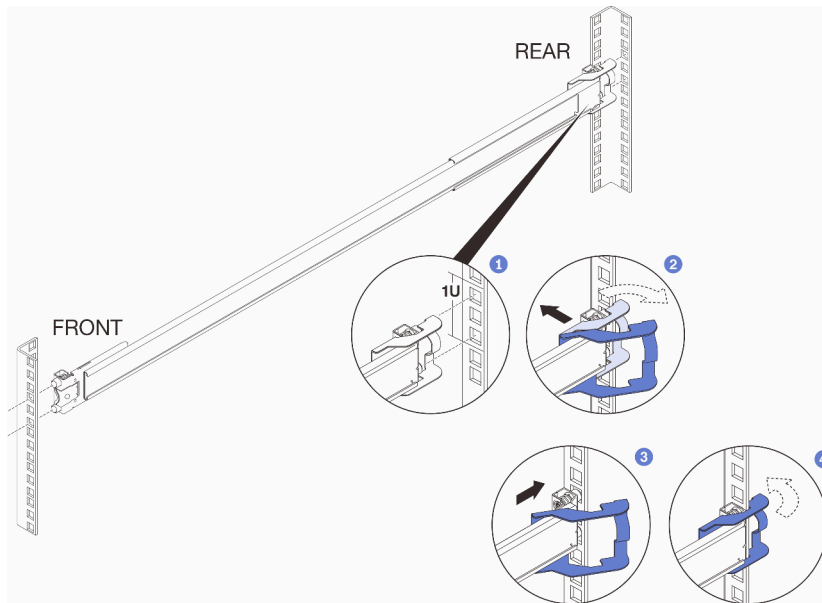

**Install the front mounting bracket to the rack:**

Step 1. Open the front mounting bracket, and align the front pins of the outer rail to the holes in the rack.

**Important:** Make sure that both ends of the rail are seated at the same height.

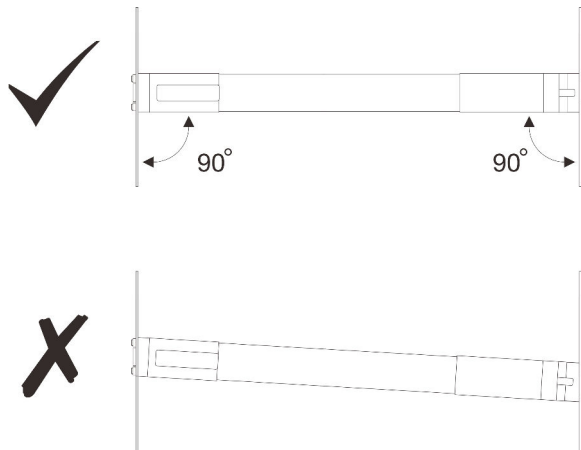

Step 2. Pull the outer rail as shown until the pins are inserted into the corresponding holes.

Step 3. Close the front bracket to lock the rail in position.

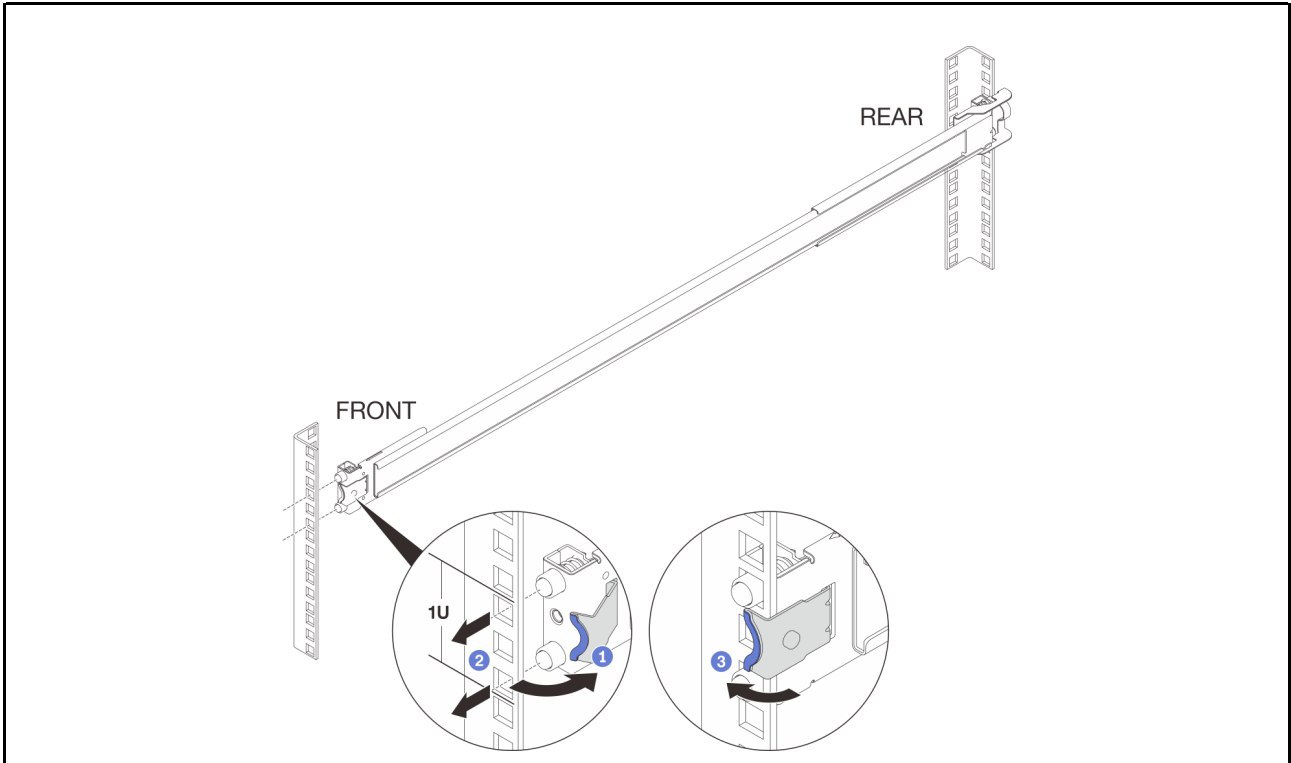

#### 4. Install rear screws (optional)

If the rack will be shipped with the server installed or the rack will be placed in a vibration-prone area, install the two M6 screws into the rear of the rails.

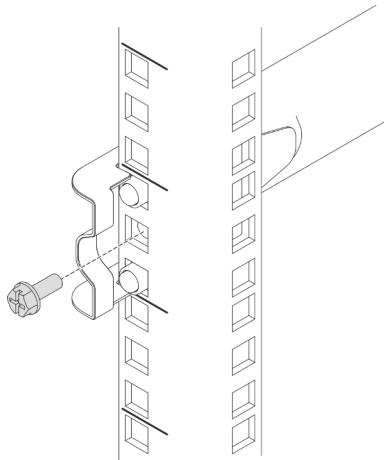

## 5. Proceed to server installation

See the “Hardware replacement procedures” chapter in the server *Maintenance Manual* or *User Guide* at ThinkSystem Documentation Center. (Link and QR code below)

<https://pubs.lenovo.com>



## Removal

### 1. Remove the server from the rails

See the “Hardware replacement procedures” chapter in the server *Maintenance Manual* or *User Guide* at ThinkSystem Documentation Center. (Link and QR code below)

<https://pubs.lenovo.com>



### 2. Remove rear screws (optional)

Remove the two M6 screws from the rear of the rails.

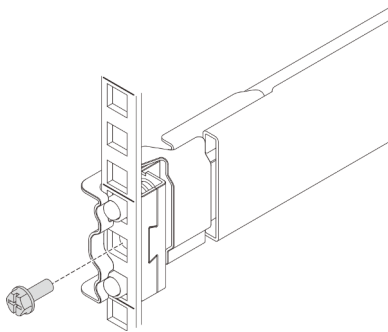

### 3. Remove the outer rails from the rack

Remove one of the rails according to the following steps.

#### Remove the front mounting bracket from the rack:

Step 1. Open the front mounting bracket.

Step 2. Slightly move the rail aside to release the pins from the frame. Push the rail outward as shown.

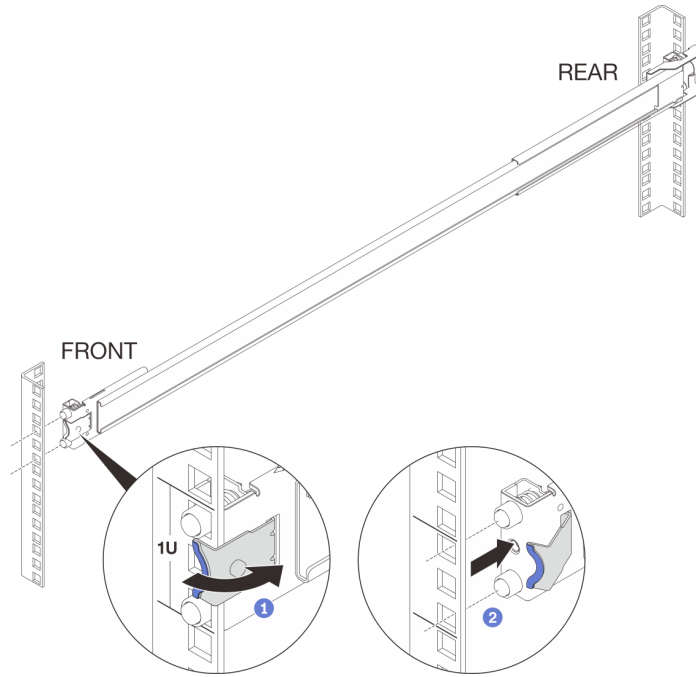

#### Remove the rear mounting bracket from the rack:

Step 1. Open the rear mounting bracket.

Step 2. Slightly move the rail aside to release the pins from the frame. Pull the rail outward as shown.

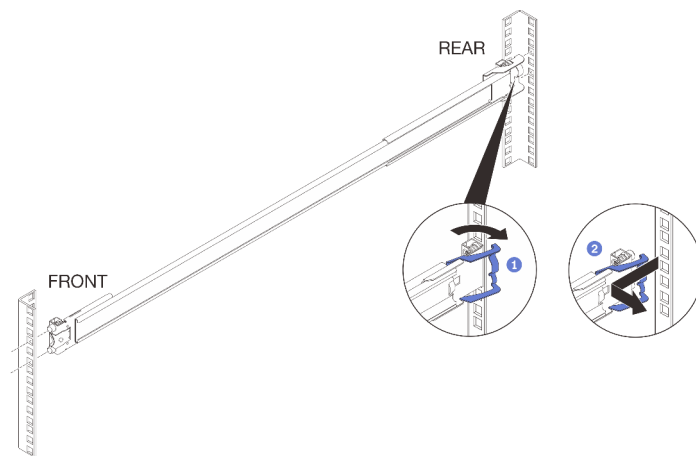

Repeat the previous steps to remove the front and rear mounting bracket of the other rail.



#### 4. Remove the inner rails from the server

**Note:** The appearance of the server and the number of the rail mounting pins on the side of the server may be different depending on the server model.

Step 1. Depending on the model, loosen the one or two M3.5 screws that secure the inner rail.

Step 2. Open the front latch on the inner rail.

Step 3. Slightly push the inner rail to the right and release the inner rail from the mounting pins on the server as shown.

Step 4. Repeat Step 1 to Step 3 to remove the other rail.

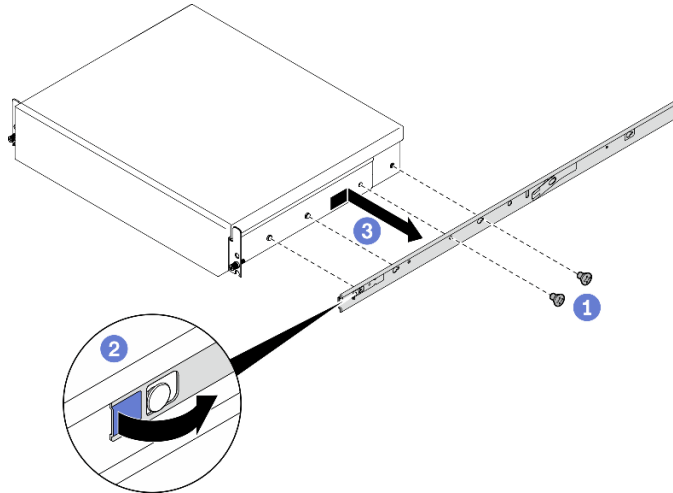

#### 5. Engage the inner rails with the outer rails

Step 1. Align the outer rail to insert and push the inner rail until it stops.

Step 2. Press the release latch to push continuously until the inner rail is completely engaged with the outer one.

Step 3. Repeat Step 1 to Step 2 to engage the other rail.

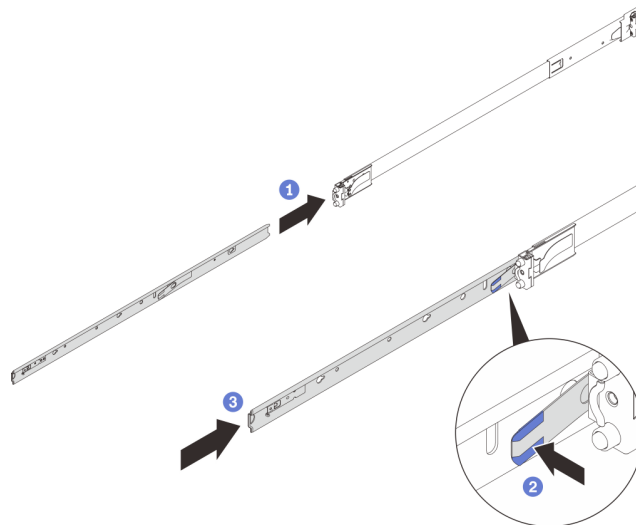

---

**First Edition (April 2022)**

**© Copyright Lenovo 2022.**

**LENOVO and THINKSYSTEM are trademarks of Lenovo. All other trademarks are the property of their respective owners.**

LIMITED AND RESTRICTED RIGHTS NOTICE: If data or software is delivered pursuant to a General Services Administration (GSA) contract, use, reproduction, or disclosure is subject to restrictions set forth in Contract No. GS-35F-05925.

Printed in China

(1P) P/N: SP47A76687

