



ThinkSystem SR780a V3 System Configuration Guide



Machine Types: 7DJ5

Note

Before using this information and the product it supports, be sure to read and understand the safety information and the safety instructions, which are available at:

https://pubs.lenovo.com/safety_documentation/

In addition, be sure that you are familiar with the terms and conditions of the Lenovo warranty for your server, which can be found at:

<http://datacentersupport.lenovo.com/warrantylookup>

First Edition (September 2024)

© Copyright Lenovo 2024.

LIMITED AND RESTRICTED RIGHTS NOTICE: If data or software is delivered pursuant to a General Services Administration (GSA) contract, use, reproduction, or disclosure is subject to restrictions set forth in Contract No. GS-35F-05925.

Contents

| | | | |
|--|-------------|---|-----------|
| Contents | i | Power cords | 50 |
| Safety | .iii | Chapter 4. Unboxing and setup | 53 |
| Safety inspection checklist | iv | Server package contents | 53 |
| Chapter 1. Introduction | 1 | Identify the server and access the Lenovo XClarity Controller | 53 |
| Features. | 1 | Server setup checklist | 55 |
| Tech Tips | 2 | Chapter 5. System configuration | 57 |
| Security advisories | 3 | Set the network connection for the Lenovo XClarity Controller | 57 |
| Specifications | 3 | Set USB port for Lenovo XClarity Controller connection. | 58 |
| Technical specifications. | 3 | Update the firmware | 59 |
| Mechanical specifications | 6 | Configure the firmware | 62 |
| Environmental specifications | 6 | Memory module configuration | 63 |
| Management options. | 8 | Enable Software Guard Extensions (SGX). | 64 |
| Chapter 2. Server components | 13 | RAID configuration | 64 |
| Front view | 13 | Deploy the operating system. | 65 |
| Rear view with two PCIe risers | 15 | Back up the server configuration | 66 |
| Rear view with two PCIe risers | 15 | Enable Intel® On Demand | 66 |
| Rear view with rear drive cage | 17 | Enable Intel® On Demand Troubleshooting | 76 |
| Top view | 19 | Appendix A. Getting help and technical assistance | 77 |
| Top view with two PCIe risers | 19 | Before you call | 77 |
| Top view with rear drive cage. | 22 | Collecting service data | 78 |
| Front I/O module | 26 | Contacting Support | 79 |
| System board connectors. | 27 | Appendix B. Documents and supports | 81 |
| System board switches | 28 | Documents download | 81 |
| System I/O board connectors | 30 | Support websites | 81 |
| System LEDs and diagnostics display | 31 | Appendix C. Notices. | 83 |
| Troubleshooting by system LEDs and diagnostics display | 31 | Trademarks | 84 |
| Drive LEDs | 31 | Important notes. | 84 |
| System I/O board LEDs | 32 | Electronic emission notices | 84 |
| Power supply LEDs | 34 | Taiwan Region BSMI RoHS declaration | 85 |
| Rear system LEDs | 35 | Taiwan Region import and export contact information | 85 |
| System board LEDs | 36 | | |
| XCC system management port LEDs. | 38 | | |
| Integrated diagnostics panel | 38 | | |
| leakage sensor module LED | 44 | | |
| Chapter 3. Parts list | 47 | | |

Safety

Before installing this product, read the Safety Information.

قبل تركيب هذا المنتج، يجب قراءة الملاحظات الأمنية

Antes de instalar este produto, leia as Informações de Segurança.

在安装本产品之前，请仔细阅读 Safety Information（安全信息）。

安裝本產品之前，請先閱讀「安全資訊」。

Prije instalacije ovog produkta obavezno pročitajte Sigurnosne Upute.

Před instalací tohoto produktu si přečtěte příručku bezpečnostních instrukcí.

Læs sikkerhedsforskrifterne, før du installerer dette produkt.

Lees voordat u dit product installeert eerst de veiligheidsvoorschriften.

Ennen kuin asennat tämän tuotteen, lue turvaohjeet kohdasta Safety Information.

Avant d'installer ce produit, lisez les consignes de sécurité.

Vor der Installation dieses Produkts die Sicherheitshinweise lesen.

Πριν εγκαταστήσετε το προϊόν αυτό, διαβάστε τις πληροφορίες ασφάλειας (safety information).

לפני שתתקינו מוצר זה, קראו את הוראות הבטיחות.

A termék telepítése előtt olvassa el a Biztonsági előírásokat!

Prima di installare questo prodotto, leggere le Informazioni sulla Sicurezza.

製品の設置の前に、安全情報をお読みください。

본 제품을 설치하기 전에 안전 정보를 읽으십시오.

Пред да се инсталира овој продукт, прочитајте информацијата за безбедност.

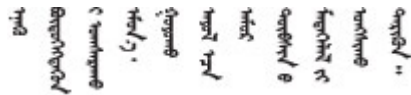

Les sikkerhetsinformasjonen (Safety Information) før du installerer dette produktet.

Przed zainstalowaniem tego produktu, należy zapoznać się z książką "Informacje dotyczące bezpieczeństwa" (Safety Information).

Antes de instalar este produto, leia as Informações sobre Segurança.

Перед установкой продукта прочтите инструкции по технике безопасности.

Pred inštaláciou tohto zariadenia si pečítajte Bezpečnostné predpisy.

Pred namestitvijo tega proizvoda preberite Varnostne informacije.

Antes de instalar este producto, lea la información de seguridad.

Läs säkerhetsinformationen innan du installerar den här produkten.

ཐོན་ཇུས་འདི་བདེ་སྤྱོད་མ་བྱས་གོང་། སྐྱར་གྱི་ཡིད་གཟབ་
བྱ་འདྲ་མིན་ཡོད་པའི་འོད་ཟེར་བལྟ་དགོས།

Bu ürünü kurmadan önce güvenlik bilgilerini okuyun.

مەزكۇر مەھسۇلاتنى ئورنىتىشتىن بۇرۇن بىخەتەرلىك ئۇچۇرلىرىنى ئوقۇپ چىقىڭ.

Youq mwngz yungh canjbinj neix gaxgonq, itdingh aeu doeg aen
canjbinj soengq cungj vahgangj ancien siusik.

Safety inspection checklist

Use the information in this section to identify potentially unsafe conditions with your server. As each machine was designed and built, required safety items were installed to protect users and service technicians from injury.

Note: The product is not suitable for use at visual display workplaces according to §2 of the Workplace Regulations.

Note: The set-up of the server is made in the server room only.

CAUTION:

This equipment must be serviced by trained personnel, as defined by the IEC 62368-1, the standard for Safety of Electronic Equipment within the Field of Audio/Video, Information Technology and Communication Technology. Lenovo assumes you are qualified in the servicing of equipment and trained in recognizing hazards energy levels in products. Equipment must be installed in a restricted access location and access to the equipment is controlled by the authority responsible for the location.

Important: Electrical grounding of the server is required for operator safety and correct system function. Proper grounding of the electrical outlet can be verified by a certified electrician.

Use the following checklist to verify that there are no potentially unsafe conditions:

1. Make sure that the power is off and the power cord is disconnected.
2. Check the power cord.
 - Make sure that the third-wire ground connector is in good condition. Use a meter to measure third-wire ground continuity for 0.1 ohm or less between the external ground pin and the frame ground.
 - Make sure that the power cord is the correct type.

To view the power cords that are available for the server:

- a. Go to:

<http://dcsc.lenovo.com/#/>

- b. Click **Preconfigured Model** or **Configure to order**.
 - c. Enter the machine type and model for your server to display the configurator page.
 - d. Click **Power → Power Cables** to see all line cords.
- Make sure that the insulation is not frayed or worn.
3. Check for any obvious non-Lenovo alterations. Use good judgment as to the safety of any non-Lenovo alterations.
 4. Check inside the server for any obvious unsafe conditions, such as metal filings, contamination, water or other liquid, or signs of fire or smoke damage.
 5. Check for worn, frayed, or pinched cables.
 6. Make sure that the power-supply cover fasteners (screws or rivets) have not been removed or tampered with.
 7. The design of the electrical distribution system must take into consideration the total grounding leakage current from all power supplies in the server.

CAUTION:



High touch current. Connect to earth before connecting to supply.

8. Use the PDUs (power distribution units) with pluggable equipment type B to distribute electrical power to servers.

Chapter 1. Introduction

The ThinkSystem SR780a V3 server (Type 7DJ5) is a powerful liquid-cooled 5U server that features two 5th Gen Intel Xeon Scalable processors and eight high-performance GPUs. Through liquid cooling, this system achieves the extensive computational prowess crucial for handling demanding AI and HPC workloads.

Figure 1. ThinkSystem SR780a V3



Features

Performance, ease of use, reliability, and expansion capabilities were key considerations in the design of your server. These design features make it possible for you to customize the system hardware to meet your needs today and provide flexible expansion capabilities for the future.

Your server implements the following features and technologies:

- **Features on Demand**

If a Features on Demand feature is integrated in the server or in an optional device that is installed in the server, you can purchase an activation key to activate the feature. For information about Features on Demand, see:

<https://fod.lenovo.com/lkms>

Intel® On Demand is a feature that allows user to customize processor capabilities according to workload and tasks at hand. For more information, see “Enable Intel® On Demand” in *User Guide*.

- **Lenovo XClarity Controller (XCC)**

The Lenovo XClarity Controller is the common management controller for Lenovo ThinkSystem server hardware. The Lenovo XClarity Controller consolidates multiple management functions in a single chip on the server system board (system board assembly). Some of the features that are unique to the Lenovo XClarity Controller are enhanced performance, higher-resolution remote video, and expanded security options.

The server supports Lenovo XClarity Controller 2 (XCC2). For additional information about Lenovo XClarity Controller 2 (XCC2), refer to <https://pubs.lenovo.com/lxcc-overview/>.

- **UEFI-compliant server firmware**

Lenovo ThinkSystem firmware is Unified Extensible Firmware Interface (UEFI) compliant. UEFI replaces BIOS and defines a standard interface between the operating system, platform firmware, and external devices.

Lenovo ThinkSystem servers are capable of booting UEFI-compliant operating systems, BIOS-based operating systems, and BIOS-based adapters as well as UEFI-compliant adapters.

Note: The server does not support Disk Operating System (DOS).

- **Large system-memory capacity**

The server supports registered DIMMs (RDIMMs) with error correcting code (ECC) and 3DS RDIMM. For more information about the specific types and maximum amount of memory, see [“Technical specifications” on page 3](#).

- **Large data-storage capacity and hot-swap capability**

With the hot-swap feature, you can add, remove, or replace hard disk drives without turning off the server.

Storage capacity is different depending on server model. See [“Technical specifications” on page 3](#) for more information.

- **Lightpath Diagnostics**

Lightpath Diagnostics provides LEDs to help you diagnose problems. For more information about the Lightpath Diagnostics, see [“Troubleshooting by system LEDs and diagnostics display” on page 31](#).

- **Mobile access to Lenovo Service Information website**

The server provides a QR code on the system service label, which is on the cover of the server, that you can scan using a QR code reader and scanner with a mobile device to get quick access to the Lenovo Service Information website. The Lenovo Service Information website provides additional information for parts installation, replacement videos, and error codes for server support.

- **Active Energy Manager**

Lenovo XClarity Energy Manager is a power and temperature management solution for data centers. You can monitor and manage the power consumption and temperature of Converged, NeXtScale, System x, and ThinkServer servers, and improve energy efficiency using Lenovo XClarity Energy Manager.

- **Redundant networking connection**

The Lenovo XClarity Controller provides failover capability to a redundant Ethernet connection with the applicable application installed. If a problem occurs with the primary Ethernet connection, all Ethernet traffic that is associated with the primary connection is automatically switched to the optional redundant Ethernet connection. If the applicable device drivers are installed, this switching occurs without data loss and without user intervention.

- **Redundant cooling**

The redundant cooling by the fans in the server enables continued operation if one of the fans fails.

Tech Tips

Lenovo continually updates the support website with the latest tips and techniques that you can use to solve issues that your server might encounter. These Tech Tips (also called retain tips or service bulletins) provide procedures to work around issues or solve problems related to the operation of your server.

To find the Tech Tips available for your server:

1. Go to <http://datacentersupport.lenovo.com> and navigate to the support page for your server.
2. Click on **How To's** from the navigation pane.
3. Click **Article Type** → **Solution** from the drop-down menu.

Follow the on-screen instructions to choose the category for the problem that you are having.

Security advisories

Lenovo is committed to developing products and services that adhere to the highest security standards in order to protect our customers and their data. When potential vulnerabilities are reported, it is the responsibility of the Lenovo Product Security Incident Response Team (PSIRT) to investigate and provide information to our customers so they may put mitigation plans in place as we work toward providing solutions.

The list of current advisories is available at the following site:

https://datacentersupport.lenovo.com/product_security/home

Specifications

Summary of the features and specifications of the server. Depending on the model, some features might not be available, or some specifications might not apply.

Refer to the below table for specifications categories and the content of each category.

| Specification category | Technical specifications | Mechanical specifications | Environmental specifications |
|------------------------|--|--|---|
| Content | <ul style="list-style-type: none">• Processor• Memory• M.2 Drive• Storage expansion• Expansion slots• Graphics processing unit (GPU)• Integrated functions and I/O connectors• Network• RAID• System fan• Electrical input• Minimal configuration for debugging• Operating systems | <ul style="list-style-type: none">• Dimension• Weight | <ul style="list-style-type: none">• Environmental |

Technical specifications

Summary of the technical specifications of server. Depending on the model, some features might not be available, or some specifications might not apply.

Processor

Supports two 5th Gen Intel® Xeon® Scalable processors up to 350W TDP, with integrated memory controller and Intel Mesh UPI (Ultra Path Interconnect) topology.

- Up to two Platinum level processors with LGA 4677 sockets
- Scalable up to 56 cores per socket
- Supports UPI v2.0 links at higher width (x96) and speed: up to 12.8, 14.4, 16, 20 GT/s
- Thermal Design Power (TDP): up to 350 watts

For a list of supported processors, see: <https://serverproven.lenovo.com>.

Memory

See “Memory module installation rules and order” in *User Guide* or *Hardware Maintenance Guide* for detailed information about memory configuration and setup.

- Memory module type:
 - TruDDR5 5600MHz RDIMM: 64 GB (2Rx4) and 96 GB (2Rx4)
- Capacity
 - Minimum: 2TB
 - Maximum: 3TB
- Slots: 16 DIMM slots per processor, 32 DIMM slots in total

For a list of supported memory modules, see: <https://serverproven.lenovo.com>.

M.2 Drive

The server supports the following M.2 drive capacity:

- 960 GB
- 1.92 TB

The following form factors are supported:

- 110 mm (22110)

For a list of supported M.2 drives, see: <https://serverproven.lenovo.com>.

Storage expansion

- Up to twelve 2.5-inch hot-swap NVMe drives
- Up to two M.2 drives (Onboard VROC RAID support)

For a list of supported drives, see: <https://serverproven.lenovo.com>.

Expansion slots

- Eight front PCIe slots
- Two rear PCIe slots

For more information, see “Front view” on page 13 and “Rear view with two PCIe risers” on page 15.

Graphics processing unit (GPU)

The server supports the following GPU configurations:

- Eight NVIDIA H100 700W SXM5 GPUs with 80GB HBM3 memory
- Eight NVIDIA H200 700W SXM5 GPUs with 141GB HBM3 memory

Integrated functions and I/O connectors

- Lenovo XClarity Controller (XCC), which provides service processor control and monitoring functions, video controller, and remote keyboard, video, mouse, and remote drive capabilities.
 - The server supports Lenovo XClarity Controller 2 (XCC2). For additional information about Lenovo XClarity Controller 2 (XCC2), refer to <https://pubs.lenovo.com/lxcc-overview/>.
- Front connectors:
 - One USB 3.1 Gen 1 (5 Gbps) connector
 - One USB 2.0 connector for XCC system management function
 - One Mini DisplayPort connector
 - Integrated diagnostics panel
 - Power button and power LED (green)
 - Network Activity LED (green)
 - System ID button/LED (blue)
 - System Error LED (yellow)
- Rear connectors:
 - One XCC system management port (10/100/1000 Mbps RJ-45) on the rear to connect to a systems-management network. This RJ-45 connector is dedicated to the Lenovo XClarity Controller functions.
 - Two USB 3.1 Gen 1 (5 Gbps) connectors
 - One VGA connector

Note: The maximum video resolution is 1920 x 1200 at 60 Hz.

Network

Rear FHHL PCIe Ethernet Adapter

RAID

Onboard software RAID support for M.2 drives (Intel VROC NVMe RAID):

- Intel VROC standard: requires an activation key and supports RAID level 0 and 1

System fan

- Six front fans
- Five 80 mm x 80 mm x 56 mm dual-rotor rear fans

Electrical input

Eight power supplies provide N+N redundancy support.

- 2600-watt Titanium, input power 200-240 Vac

Important: Power supplies and redundant power supplies in the server must be with the same power rating, wattage or level.

Minimal configuration for debugging

- Two processors
- Two memory modules
- One power supply
- One M.2 drive (If OS is needed by debugging)
- Six front fans
- Five rear fans
- One rear PCIe Ethernet Adapter (If network is required)
- CPU water loop connected to water (If connected to DC power)

Operating systems

Supported and certified operating system:

- Canonical Ubuntu

References:

- Complete list of available operating systems: <https://lenovopress.lenovo.com/osig>.
- OS deployment instructions, see “Deploy the operating system” on page 65.

Mechanical specifications

Summary of the mechanical specifications of server. Depending on the model, some features might not be available, or some specifications might not apply.

Dimension

- Height: 218.5 mm (8.6 inches)
- Width:
 - With EIA flange: 482.4 mm (19 inches)
 - Without EIA flange: 447 mm (17.6 inches)
- Depth:
 - With EIA flange and PSU: 958.4 mm (37.7 inches)
 - Chassis: 909.2 mm (35.8 inches)

Weight

- Approximately 90 kg (198.4 lbs) with H100/H200 GPU complex, depending on the configuration

Environmental specifications

Summary of the environmental specifications of server. Depending on the model, some features might not be available, or some specifications might not apply.

Ambient temperature management

Ambient temperature management

Adjust ambient temperature when specific components are installed.

Keep the ambient temperature to 30°C or lower when ThinkSystem NVIDIA BlueField-3 B3220 VPI QSFP112 2P 200G PCIe Gen5 x16 Adapter is installed in PCIe riser 1 (PCIe slot 9).

Environment

| Environment |
|--|
| <p>ThinkSystem SR780a V3 complies with ASHRAE Class A2 specifications. System performance may be impacted when operating temperature is outside ASHRAE A2 specification.</p> <ul style="list-style-type: none">• Air temperature:<ul style="list-style-type: none">– Operating<ul style="list-style-type: none">– ASHRAE Class A2: 10°C to 35°C (50°F to 95°F); the maximum ambient temperature decreases by 1°C for every 300 m (984 ft) increase in altitude above 900 m (2,953 ft).– Server off: 5°C to 45°C (41°F to 113°F)– Shipment/storage: -20°C to 60°C (-4°F to 140°F)• Maximum altitude: 3,050 m (10,000 ft)• Relative Humidity (non-condensing):<ul style="list-style-type: none">– Operating<ul style="list-style-type: none">– ASHRAE Class A2: 8% to 80%; maximum dew point: 21°C (70°F)– Shipment/storage: 8% to 90%• Particulate contamination <p>Attention: Airborne particulates and reactive gases acting alone or in combination with other environmental factors such as humidity or temperature might pose a risk to the server. For information about the limits for particulates and gases, see “Particulate contamination” on page 7.</p> <p>Note: The server is designed for standard data center environment and recommended to be placed in industrial data center.</p> |

Water requirements

| Water requirements |
|---|
| <ul style="list-style-type: none">• Water temperature:<ul style="list-style-type: none">– ASHRAE class W45: up to 45°C (113°F) inlet temperature to the rack• Maximum pressure: 4.4 bars• Minimum water flow rate: 10.0 liters per minute per Chassis <p>Note: The water required to initially fill the system side cooling loop must be reasonably clean, bacteria-free water (<100 CFU/ml) such as de-mineralized water, reverse osmosis water, de-ionized water, or distilled water. The water must be filtered with an in-line 50 micron filter (approximately 288 mesh). The water must be treated with anti-biological and anti-corrosion measures.</p> |

Particulate contamination

Attention: Airborne particulates (including metal flakes or particles) and reactive gases acting alone or in combination with other environmental factors such as humidity or temperature might pose a risk to the device that is described in this document.

Risks that are posed by the presence of excessive particulate levels or concentrations of harmful gases include damage that might cause the device to malfunction or cease functioning altogether. This specification sets forth limits for particulates and gases that are intended to avoid such damage. The limits must not be viewed or used as definitive limits, because numerous other factors, such as temperature or moisture content of the air, can influence the impact of particulates or environmental corrosives and gaseous contaminant transfer. In the absence of specific limits that are set forth in this document, you must implement practices that maintain particulate and gas levels that are consistent with the protection of human health and safety. If Lenovo determines that the levels of particulates or gases in your environment have caused damage to the device, Lenovo may condition provision of repair or replacement of devices or parts on implementation of appropriate remedial measures to mitigate such environmental contamination. Implementation of such remedial measures is a customer responsibility.

Table 1. Limits for particulates and gases

| Contaminant | Limits |
|-----------------------|--|
| Reactive gases | <p>Severity level G1 as per ANSI/ISA 71.04-1985¹:</p> <ul style="list-style-type: none"> • The copper reactivity level shall be less than 200 Angstroms per month ($\text{\AA}/\text{month} \approx 0.0035 \mu\text{g}/\text{cm}^2\text{-hour}$ weight gain).² • The silver reactivity level shall be less than 200 Angstroms per month ($\text{\AA}/\text{month} \approx 0.0035 \mu\text{g}/\text{cm}^2\text{-hour}$ weight gain).³ • The reactive monitoring of gaseous corrosivity must be conducted approximately 5 cm (2 in.) in front of the rack on the air inlet side at one-quarter and three-quarter frame height off the floor or where the air velocity is much higher. |
| Airborne particulates | <p>Data centers must meet the cleanliness level of ISO 14644-1 class 8.</p> <p>For data centers without airside economizer, the ISO 14644-1 class 8 cleanliness might be met by choosing one of the following filtration methods:</p> <ul style="list-style-type: none"> • The room air might be continuously filtered with MERV 8 filters. • Air entering a data center might be filtered with MERV 11 or preferably MERV 13 filters. <p>For data centers with airside economizers, the choice of filters to achieve ISO class 8 cleanliness depends on the specific conditions present at that data center.</p> <ul style="list-style-type: none"> • The deliquescent relative humidity of the particulate contamination should be more than 60% RH.⁴ • Data centers must be free of zinc whiskers.⁵ |

¹ ANSI/ISA-71.04-1985. *Environmental conditions for process measurement and control systems: Airborne contaminants*. Instrument Society of America, Research Triangle Park, North Carolina, U.S.A.

² The derivation of the equivalence between the rate of copper corrosion growth in the thickness of the corrosion product in $\text{\AA}/\text{month}$ and the rate of weight gain assumes that Cu_2S and Cu_2O grow in equal proportions.

³ The derivation of the equivalence between the rate of silver corrosion growth in the thickness of the corrosion product in $\text{\AA}/\text{month}$ and the rate of weight gain assumes that Ag_2S is the only corrosion product.

⁴ The deliquescent relative humidity of particulate contamination is the relative humidity at which the dust absorbs enough water to become wet and promote ionic conduction.

⁵ Surface debris is randomly collected from 10 areas of the data center on a 1.5 cm diameter disk of sticky electrically conductive tape on a metal stub. If examination of the sticky tape in a scanning electron microscope reveals no zinc whiskers, the data center is considered free of zinc whiskers.

Management options

The XClarity portfolio and other system management options described in this section are available to help you manage the servers more conveniently and efficiently.

Overview

| Options | Description |
|------------------------------------|---|
| Lenovo XClarity Controller | <p>Baseboard management controller (BMC)</p> <p>Consolidates the service processor functionality, Super I/O, video controller, and remote presence capabilities into a single chip on the server system board (system board assembly).</p> <p>Interface</p> <ul style="list-style-type: none"> • CLI application • Web GUI interface • Mobile application • Redfish API <p>Usage and downloads</p> <p>https://pubs.lenovo.com/lxcc-overview/</p> |
| Lenovo XCC Logger Utility | <p>Application that reports the XCC events to local OS system log.</p> <p>Interface</p> <ul style="list-style-type: none"> • CLI application <p>Usage and downloads</p> <ul style="list-style-type: none"> • https://pubs.lenovo.com/lxcc-logger-linux/ • https://pubs.lenovo.com/lxcc-logger-windows/ |
| Lenovo XClarity Administrator | <p>Centralized interface for multi-server management.</p> <p>Interface</p> <ul style="list-style-type: none"> • Web GUI interface • Mobile application • REST API <p>Usage and downloads</p> <p>https://pubs.lenovo.com/lxca/</p> |
| Lenovo XClarity Essentials toolset | <p>Portable and light toolset for server configuration, data collection, and firmware updates. Suitable both for single-server or multi-server management contexts.</p> <p>Interface</p> <ul style="list-style-type: none"> • OneCLI: CLI application • Bootable Media Creator: CLI application, GUI application • UpdateXpress: GUI application <p>Usage and downloads</p> <p>https://pubs.lenovo.com/lxce-overview/</p> |

| Options | Description |
|--------------------------------------|---|
| Lenovo XClarity Provisioning Manager | <p>UEFI-based embedded GUI tool on a single server that can simplify management tasks.</p> <p>Interface</p> <ul style="list-style-type: none"> • Web interface (BMC remote access) • GUI application <p>Usage and downloads</p> <p>https://pubs.lenovo.com/lxpm-overview/</p> <p>Important: Lenovo XClarity Provisioning Manager (LXPM) supported version varies by product. All versions of Lenovo XClarity Provisioning Manager are referred to as Lenovo XClarity Provisioning Manager and LXPM in this document, unless specified otherwise. To see the LXPM version supported by your server, go to https://pubs.lenovo.com/lxpm-overview/.</p> |
| Lenovo XClarity Integrator | <p>Series of applications that integrate the management and monitoring functionalities of the Lenovo physical servers with the software used in a certain deployment infrastructure, such as VMware vCenter, Microsoft Admin Center, or Microsoft System Center while delivering additional workload resiliency.</p> <p>Interface</p> <ul style="list-style-type: none"> • GUI application <p>Usage and downloads</p> <p>https://pubs.lenovo.com/lxci-overview/</p> |
| Lenovo XClarity Energy Manager | <p>Application that can manage and monitor server power and temperature.</p> <p>Interface</p> <ul style="list-style-type: none"> • Web GUI Interface <p>Usage and downloads</p> <p>https://datacentersupport.lenovo.com/solutions/Invo-lxem</p> |
| Lenovo Capacity Planner | <p>Application that supports power consumption planning for a server or rack.</p> <p>Interface</p> <ul style="list-style-type: none"> • Web GUI Interface <p>Usage and downloads</p> <p>https://datacentersupport.lenovo.com/solutions/Invo-lcp</p> |

Functions

| Options | | Functions | | | | | | | |
|--------------------------------------|------------------------|-------------------|----------------|----------------------|-------------------------------|------------------------|----------------|----------------|----------------|
| | | Multi-system mgmt | OS deployment | System configuration | Firmware updates ¹ | Event/alert monitoring | Inventory/logs | Power mgmt | Power planning |
| Lenovo XClarity Controller | | | | √ | √ ² | √ | √ ⁴ | | |
| Lenovo XCC Logger Utility | | | | | | √ | | | |
| Lenovo XClarity Administrator | | √ | √ | √ | √ ² | √ | √ ⁴ | | |
| Lenovo XClarity Essentials toolset | OneCLI | √ | | √ | √ ² | √ | √ | | |
| | Bootable Media Creator | | | √ | √ ² | | √ ⁴ | | |
| | UpdateXpress | | | √ | √ ² | | | | |
| Lenovo XClarity Provisioning Manager | | | √ | √ | √ ³ | | √ ⁵ | | |
| Lenovo XClarity Integrator | | √ | √ ⁶ | √ | √ | √ | √ | √ ⁷ | |
| Lenovo XClarity Energy Manager | | √ | | | | √ | | √ | |
| Lenovo Capacity Planner | | | | | | | | | √ ⁸ |

Notes:

1. Most options can be updated through the Lenovo tools. Some options, such as GPU firmware or Omni-Path firmware require the use of supplier tools.
2. The server UEFI settings for option ROM must be set to **Auto** or **UEFI** to update firmware using Lenovo XClarity Administrator, Lenovo XClarity Essentials, or Lenovo XClarity Controller.
3. Firmware updates are limited to Lenovo XClarity Provisioning Manager, Lenovo XClarity Controller, and UEFI updates only. Firmware updates for optional devices, such as adapters, are not supported.
4. The server UEFI settings for option ROM must be set to **Auto** or **UEFI** for detailed adapter card information, such as model name and firmware levels, to be displayed in Lenovo XClarity Administrator, Lenovo XClarity Controller, or Lenovo XClarity Essentials.
5. Limited inventory.
6. The Lenovo XClarity Integrator deployment check for System Center Configuration Manager (SCCM) supports Windows operating system deployment.
7. Power management function is supported only by Lenovo XClarity Integrator for VMware vCenter.
8. It is highly recommended that you check the power summary data for your server using Lenovo Capacity Planner before purchasing any new parts.

Chapter 2. Server components

This section contains information about each of the components associated with the server.

Front view

This section contains information on the front view.

Note: The illustration in this section show the location of certain parts. Some parts may not be supported at the same time within certain configuration(s).

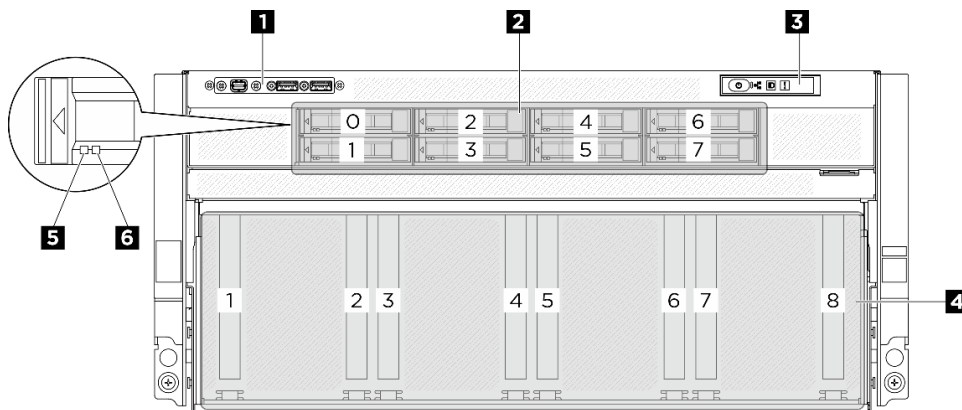

Figure 2. Front view

Table 2. Components on the front view

| | |
|---------------------------------------|--|
| 1 Front I/O module | 2 2.5-inch drive bays (bay 0 to 7) |
| 3 Integrated diagnostics panel | 4 PCIe switch shuttle (PCIe slot 1-8) |
| 5 Drive status LED (green) | 6 Drive activity LED (yellow) |

1 Front I/O module

For more information about the front I/O module, see [“Front I/O module” on page 26](#).

2 2.5-inch drive bays (bay 0 to 7)

Install 2.5-inch NVMe drives to these bays. See [“Install a 2.5-inch hot-swap drive” in User Guide or Hardware Maintenance Guide](#) for more information.

3 Integrated diagnostics panel

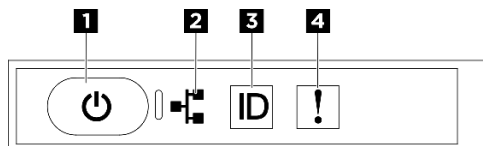

Figure 3. Integrated diagnostics panel LEDs

Table 3. Integrated diagnostics panel LEDs

| | |
|---|---------------------------------------|
| 1 Power button with power status LED (green) | 2 Network activity LED (green) |
| 3 System ID button with system ID LED (blue) | 4 System Error LED (yellow) |

1 Power button with power status LED (green)

You can press the power button to power on the server when you finish setting up the server. You also can hold the power button for several seconds to power off the server if you cannot shut down the server from the operating system. The states of the power LED are as follows:

| Status | Color | Description |
|--|-------|--|
| Off | None | No power supply is properly installed, or the LED itself has failed. |
| Flashing rapidly (four times per second) | Green | The server is turned off and is not ready to be turned on. The power button is disabled. This will last approximately 5 to 10 seconds. |
| Flashing slowly (once per second) | Green | The server is turned off and is ready to be turned on. You can press the power button to turn on the server. |
| Lit | Green | The server is turned on. |

2 Network activity LED (green)

The network activity LED helps you identify the network connectivity and activity.

Note: SR780a V3 does not have the OCP module installed. The network activity LED will blink at a constant 1 Hz rate.

| Status | Color | Description |
|----------|-------|--|
| On | Green | The server is connected to a network. |
| Blinking | Green | The network is connected and active. |
| Off | None | The server is disconnected from the network. |

3 System ID button with system ID LED (blue)

Use this system ID button and the blue system ID LED to visually locate the server. Each time you press the system ID button, the state of the system ID LED changes. The LED can be changed to on, blinking, or off. You can also use the Lenovo XClarity Controller or a remote management program to change the state of the system ID LED to assist in visually locating the server among other servers.

4 System Error LED (yellow)

The system error LED helps you to determine if there are any system errors.

| Status | Color | Description | Action |
|--------|--------|---|---|
| On | Yellow | <p>An error has been detected on the server. Causes might include one or more of the following errors:</p> <ul style="list-style-type: none"> • The temperature of the server reached the non-critical temperature threshold. • The voltage of the server reached the non-critical voltage threshold. • A fan has been detected to be running at low speed. • The power supply has a critical error. • The power supply is not connected to the power. | Check the LCD display or the event log to determine the exact cause of the error. |
| Off | None | The server is off or the server is on and is working correctly. | None. |

For more information about the integrated diagnostics panel, see [“Integrated diagnostics panel” on page 38](#).

4 PCIe switch shuttle (PCIe slot 1-8)

Install PCIe adapters to the PCIe switch shuttle. These PCIe slots support the following configuration:

- PCIe Gen5 x16, FH/HL

5 Drive activity LED (green)

Each hot-swap drive comes with an activity LED. When this LED is flashing, it indicates that the drive is in use.

6 Drive status LED (yellow)

The drive status LED indicates the following status:

- The LED is lit: the drive has failed.
- The LED is flashing slowly (once per second): the drive is being rebuilt.
- The LED is flashing rapidly (three times per second): the drive is being identified.

Rear view with two PCIe risers

The illustrations in this section provide information about the rear view of the server.

The ThinkSystem SR780a V3 rear view varies by model. Refer to the rear view specific to each model to identify the components.

- [“Rear view with two PCIe risers” on page 15](#)
- [“Rear view with rear drive cage” on page 17](#)

Rear view with two PCIe risers

This section contains information on the rear view with two PCIe risers.

Note: The illustration in this section show the location of certain parts. Some parts may not be supported at the same time within certain configuration(s).

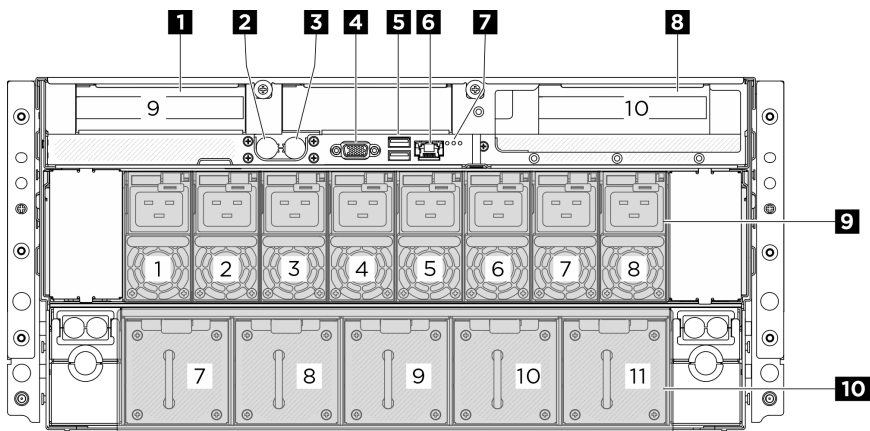

Figure 4. Rear view with two PCIe risers

Table 4. Components on the rear view with two PCIe risers

| | |
|--|---|
| 1 PCIe riser 1 (PCIe slot 9) | 2 Inlet hose |
| 3 Outlet hose | 4 VGA connector |
| 5 USB 3.1 Gen 1 (5 Gbps) connectors (total of two connectors) | 6 XCC system management port (10/100/1000 Mbps RJ-45) (1 GB RJ-45) |
| 7 Location LED/System error LED/RoT error LED | 8 PCIe riser 2 (PCIe slot 10) |
| 9 Power supply units | 10 Rear fans |

1 / 8 PCIe riser 1/2

Install PCIe adapters into these risers. See the following table for PCIe slots corresponding to the risers.

Table 5. PCIe riser and corresponding slots

| PCIe riser | PCIe slot |
|-----------------------|-------------------------------|
| 1 PCIe riser 1 | Slot 9: PCIe Gen5 x16, FH/HL |
| 6 PCIe riser 2 | Slot 10: PCIe Gen5 x16, FH/HL |

2 / 3 Inlet and outlet hoses

The Direct Water cold plate module (DWCM) spreads two hoses out to connect to the manifolds. The inlet hose conveys warm water from the facility to the cold plates to cool down the processors, and the outlet hose conducts hot water out of the DWCM to realize system cooling.

4 VGA connector

Connect a monitor to this connector.

5 USB 3.1 Gen 1 (5 Gbps) connectors

There are two USB 3.1 Gen 1 (5 Gbps) connectors on the rear of the server. Connect a USB device, such as a mouse, keyboard, or other devices, to either of these connectors.

6 XCC system management port (10/100/1000 Mbps RJ-45)

The server has a 10/100/1000 Mbps RJ-45 connector dedicated to Lenovo XClarity Controller (XCC) functions. Through the system management port, you can access the Lenovo XClarity Controller directly by connecting your laptop to the management port using an Ethernet cable. Make sure that you modify the IP

settings on the laptop so that it is on the same network as the server default settings. A dedicated management network provides additional security by physically separating the management network traffic from the production network.

See the following for more information:

- [“Set the network connection for the Lenovo XClarity Controller” on page 57](#)
- [“XCC system management port LEDs” on page 38](#)

7 Identification LED/System error LED/RoT error LED

For more information on the rear LEDs, see [“Rear system LEDs” on page 35](#).

9 Power supply units

Install power supply units to these bays, connect them to power cords. Make sure the power cords are connected properly. Following are the power supplies supported by this system:

- 2600-watt Titanium, input power 200-240 Vac

For more information on the power supply LEDs, see [“Power supply LEDs” on page 34](#).

10 Rear fans

Install rear fans in this space. See “Install a hot-swap fan” in *User Guide* or *Hardware Maintenance Guide* for more information.

Rear view with rear drive cage

This section contains information on the rear view with rear drive cage.

Note: The illustration in this section show the location of certain parts. Some parts may not be supported at the same time within certain configuration(s).

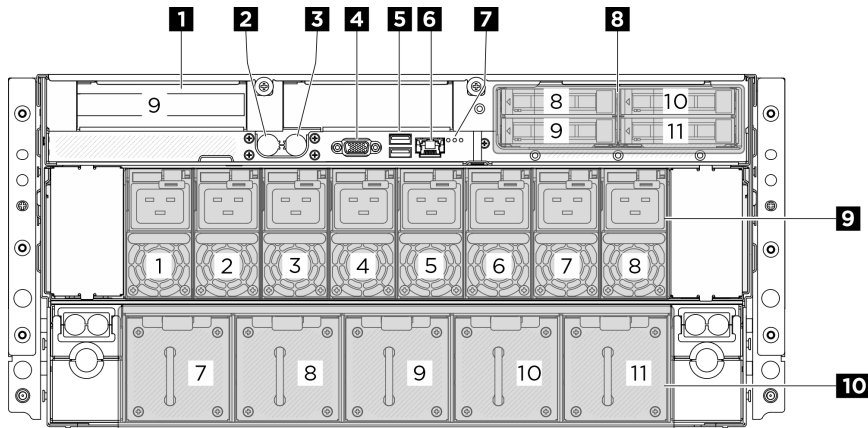

Figure 5. Rear view with rear drive cage

Table 6. Components on the rear view with rear drive cage

| | |
|--|---|
| 1 PCIe riser 1 (PCIe slot 9) | 2 Inlet hose |
| 3 Outlet hose | 4 VGA connector |
| 5 USB 3.1 Gen 1 (5 Gbps) connectors (total of two connectors) | 6 XCC system management port (10/100/1000 Mbps RJ-45) (1 GB RJ-45) |

Table 6. Components on the rear view with rear drive cage (continued)

| | |
|--|--|
| 7 Location LED/System error LED/RoT error LED | 8 2.5-inch drive bays (bay 8 to 11) |
| 9 Power supply units | 10 Rear fans |

1 PCIe riser 1

Install PCIe adapters into these risers. See the following table for PCIe slots corresponding to the risers.

Table 7. PCIe riser and corresponding slots

| PCIe riser | PCIe slot |
|-----------------------|------------------------------|
| 1 PCIe riser 1 | Slot 9: PCIe Gen5 x16, FH/HL |

2 / 3 Inlet and outlet hoses

The Direct Water cold plate module (DWCM) spreads two hoses out to connect to the manifolds. The inlet hose conveys warm water from the facility to the cold plates to cool down the processors, and the outlet hose conducts hot water out of the DWCM to realize system cooling.

4 VGA connector

Connect a monitor to this connector.

5 USB 3.1 Gen 1 (5 Gbps) connectors

There are two USB 3.1 Gen 1 (5 Gbps) connectors on the rear of the server. Connect a USB device, such as a mouse, keyboard, or other devices, to either of these connectors.

6 XCC system management port (10/100/1000 Mbps RJ-45)

The server has a 10/100/1000 Mbps RJ-45 connector dedicated to Lenovo XClarity Controller (XCC) functions. Through the system management port, you can access the Lenovo XClarity Controller directly by connecting your laptop to the management port using an Ethernet cable. Make sure that you modify the IP settings on the laptop so that it is on the same network as the server default settings. A dedicated management network provides additional security by physically separating the management network traffic from the production network.

See the following for more information:

- [“Set the network connection for the Lenovo XClarity Controller” on page 57](#)
- [“XCC system management port LEDs” on page 38](#)

7 Identification LED/System error LED/RoT error LED

For more information on the rear LEDs, see [“Rear system LEDs” on page 35](#).

8 2.5-inch drive bays (bay 8 to 11)

Install 2.5-inch NVMe drives to these bays. See “Install a 2.5-inch hot-swap drive” in *User Guide* or *Hardware Maintenance Guide* for more information.

9 Power supply units

Install power supply units to these bays, connect them to power cords. Make sure the power cords are connected properly. Following are the power supplies supported by this system:

- 2600-watt Titanium, input power 200-240 Vac

For more information on the power supply LEDs, see [“Power supply LEDs” on page 34](#).

10 Rear fans

Install rear fans in this space. See “Install a hot-swap fan” in *User Guide* or *Hardware Maintenance Guide* for more information.

Top view

The illustrations in this section provide information about the top view of the server.

The ThinkSystem SR780a V3 top view varies by model. Refer to the top view specific to each model to identify the components.

- [“Top view with two PCIe risers” on page 19](#)
- [“Top view with rear drive cage” on page 22](#)

Top view with two PCIe risers

This section contains information on the top view with two PCIe risers.

Note: The illustrations in this section show the location of certain parts. Some parts may not be supported at the same time within certain configuration(s).

- [“CPU complex top view” on page 19](#)
- [“CPU complex water loop top view” on page 20](#)
- [“Chassis top view” on page 21](#)
- [“GPU complex top view for H100/H200 GPU Model” on page 22](#)

CPU complex top view

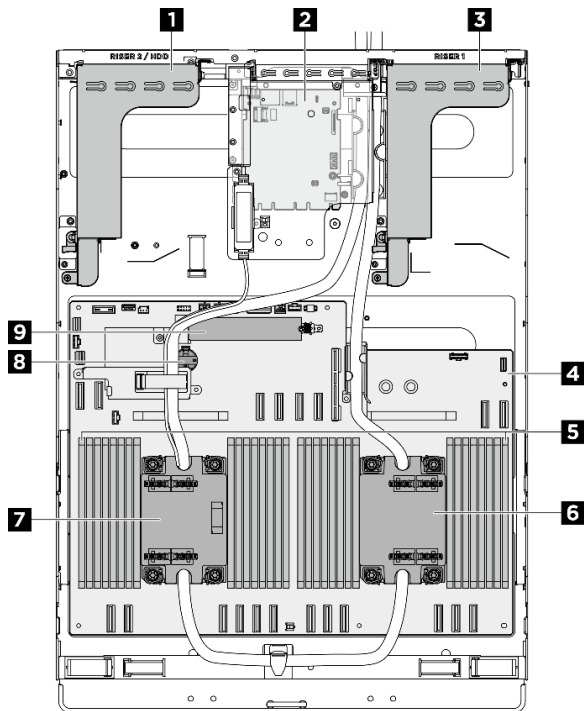

Figure 6. CPU complex top view

Table 8. Components on the CPU complex top view

| | |
|-------------------------|---------------------------|
| 1 PCIe riser 2 | 2 System I/O board |
| 3 PCIe riser 1 | 4 System board |
| 5 Memory modules | 6 Processor 1 |
| 7 Processor 0 | 8 CMOS battery |
| 9 M.2 drives | |

CPU complex water loop top view

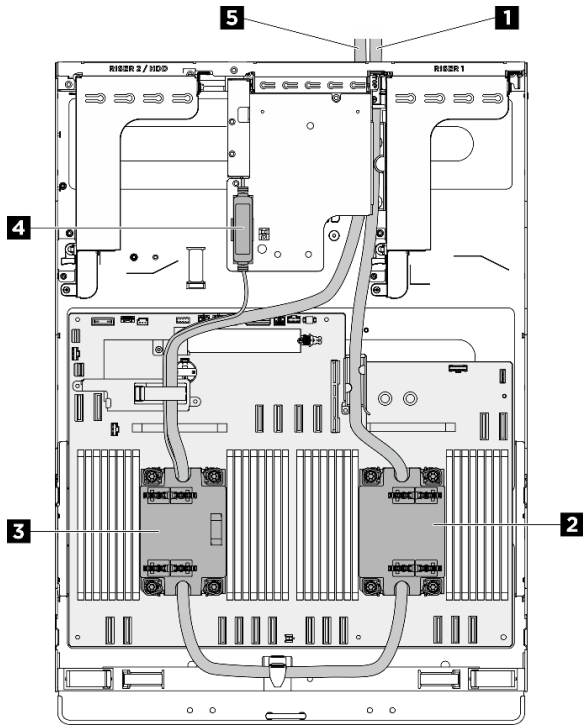

Figure 7. CPU complex water loop top view

Table 9. Components on the CPU complex water loop top view

| | |
|----------------------|--------------------------------|
| 1 Inlet hose | 2 Processor 1 |
| 3 Processor 0 | 4 Leakage sensor module |
| 5 Outlet hose | |

Chassis top view

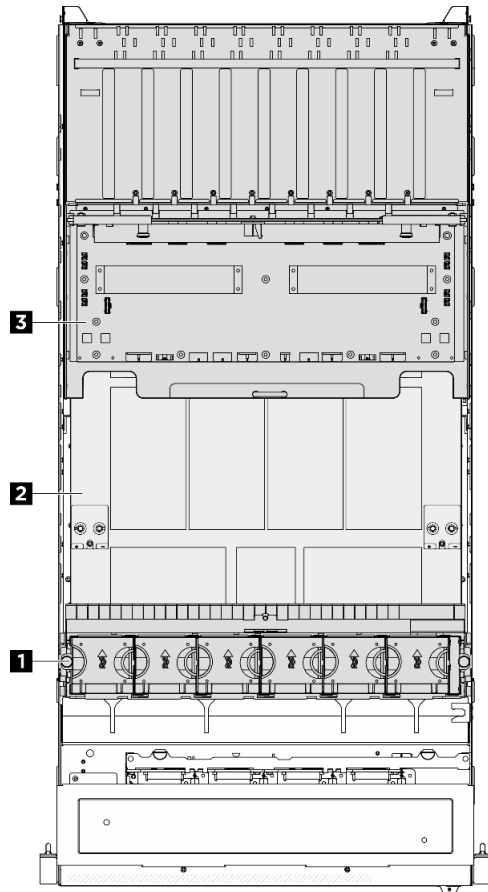

Figure 8. Chassis top view

Table 10. Components on the chassis top view

| | |
|-----------------------------------|----------------------|
| 1 Front fans | 2 GPU complex |
| 3 Power distribution board | |

GPU complex top view for H100/H200 GPU Model

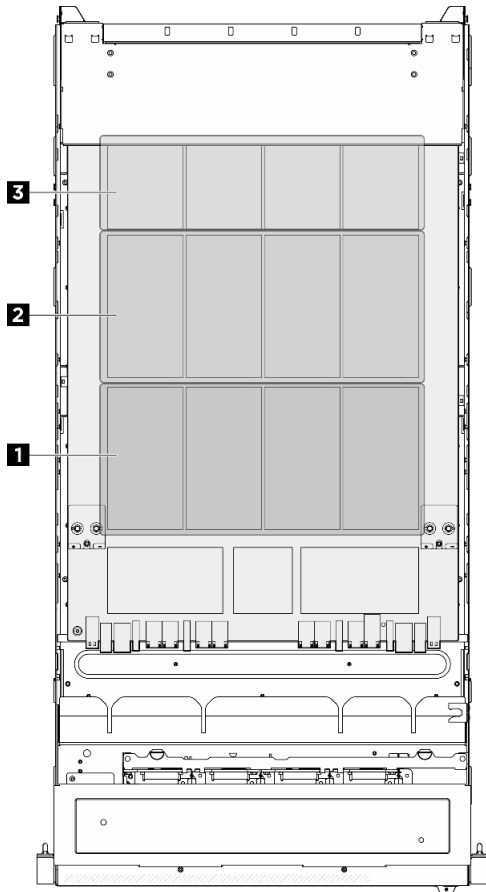

Figure 9. GPU complex top view for H100/H200 GPU Model

Table 11. Components on the GPU complex top view for H100/H200 GPU Model

| | |
|-------------------------------|------------------------------|
| 1 Front H100/H200 GPUs | 2 Rear H100/H200 GPUs |
| 3 NVSwitches | |

Top view with rear drive cage

This section contains information on the top view with rear drive cage.

Note: The illustrations in this section show the location of certain parts. Some parts may not be supported at the same time within certain configuration(s).

- [“CPU complex top view” on page 23](#)
- [“CPU complex water loop top view” on page 24](#)
- [“Chassis top view” on page 25](#)
- [“GPU complex top view for H100/H200 GPU Model” on page 26](#)

CPU complex top view

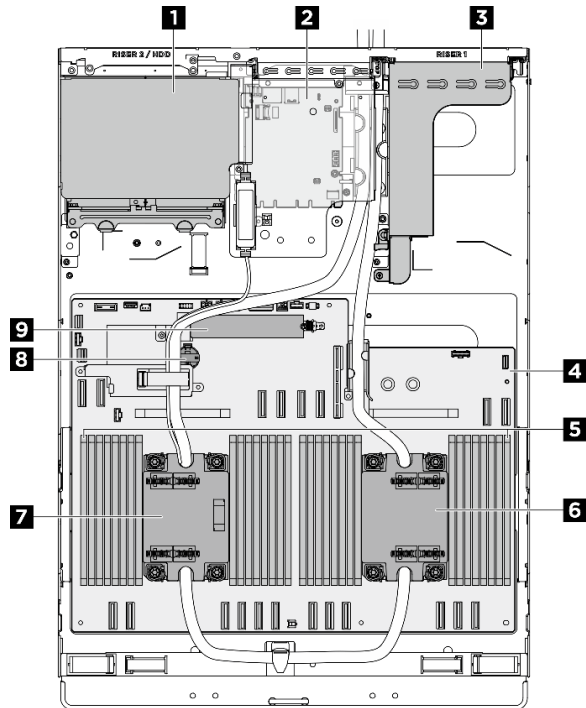

Figure 10. CPU complex top view

Table 12. Components on the CPU complex top view

| | |
|--------------------------|---------------------------|
| 1 Rear drive cage | 2 System I/O board |
| 3 PCIe riser 1 | 4 System board |
| 5 Memory modules | 6 Processor 1 |
| 7 Processor 0 | 8 CMOS battery |
| 9 M.2 drives | |

CPU complex water loop top view

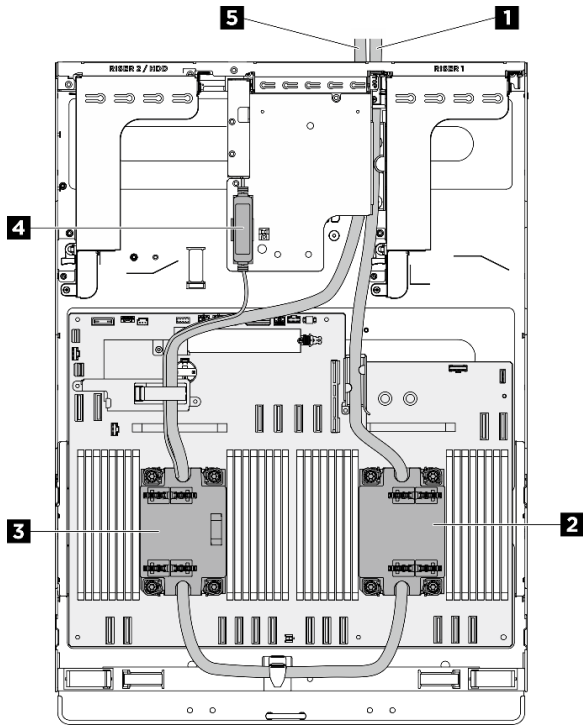

Figure 11. CPU complex water loop top view

Table 13. Components on the CPU complex water loop top view

| | |
|----------------------|--------------------------------|
| 1 Inlet hose | 2 Processor 1 |
| 3 Processor 0 | 4 Leakage sensor module |
| 5 Outlet hose | |

Chassis top view

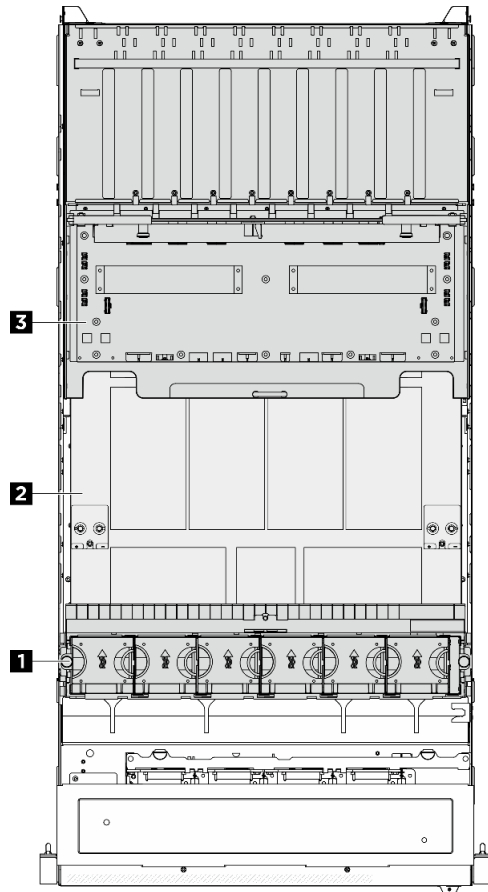

Figure 12. Chassis top view

Table 14. Components on the chassis top view

| | |
|-----------------------------------|----------------------|
| 1 Front fans | 2 GPU complex |
| 3 Power distribution board | |

GPU complex top view for H100/H200 GPU Model

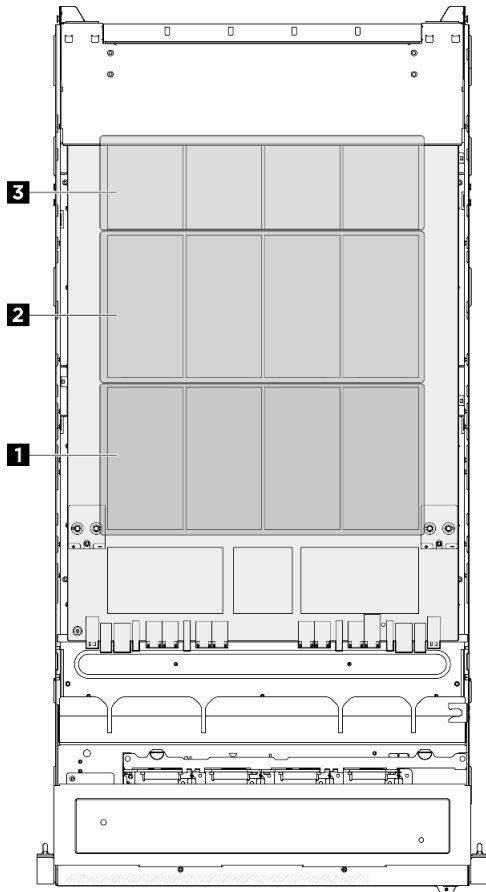

Figure 13. GPU complex top view for H100/H200 GPU Model

Table 15. Components on the GPU complex top view for H100/H200 GPU Model

| | |
|-------------------------------|------------------------------|
| 1 Front H100/H200 GPUs | 2 Rear H100/H200 GPUs |
| 3 NVSwitches | |

Front I/O module

This section contains information on the front I/O module

The following illustrations show the front I/O module. To locate the front I/O module, see [“Front view” on page 13](#).

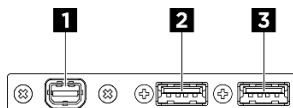

Figure 14. Front I/O module

Table 16. Components on the front I/O module

| | |
|---|---|
| 1 Mini DisplayPort connector | 2 USB 2.0 connector with Lenovo XClarity Controller Management |
| 3 USB 3.1 Gen 1 (5 Gbps) connector | |

1 Mini DisplayPort connector

Connect a monitor to this connector.

Note: The maximum video resolution is 1920 x 1200 at 60 Hz.

2 USB 2.0 connector with Lenovo XClarity Controller management

Connect a USB 2.0 device, such as a mouse, keyboard, or other devices, to this connector.

Note: This is the only USB port that supports USB automation update of the firmware and RoT security module.

Connection to Lenovo XClarity Controller is primarily intended for users with a mobile device running the Lenovo XClarity Controller mobile application. When a mobile device is connected to this USB port, an Ethernet over USB connection is established between the mobile application running on the device and the Lenovo XClarity Controller.

Select **Network** in **BMC Configuration** to view or modify settings.

Four types of settings are available:

- **Host only mode**

In this mode, the USB port is always solely connected to the server.

- **BMC only mode**

In this mode, the USB port is always solely connected to Lenovo XClarity Controller.

- **Shared mode: owned by BMC**

In this mode, connection to the USB port is shared by the server and Lenovo XClarity Controller, while the port is switched to Lenovo XClarity Controller.

- **Shared mode: owned by host**

In this mode, connection to the USB port is shared by the server and Lenovo XClarity Controller, while the port is switched to the server.

3 USB 3.1 Gen 1 (5 Gbps) connector

The USB 3.1 Gen 1 (5 Gbps) connector can be used to attach a USB-compatible device, such as a USB keyboard, USB mouse, or USB storage device.

System board connectors

The following illustration shows the internal connectors on the system board.

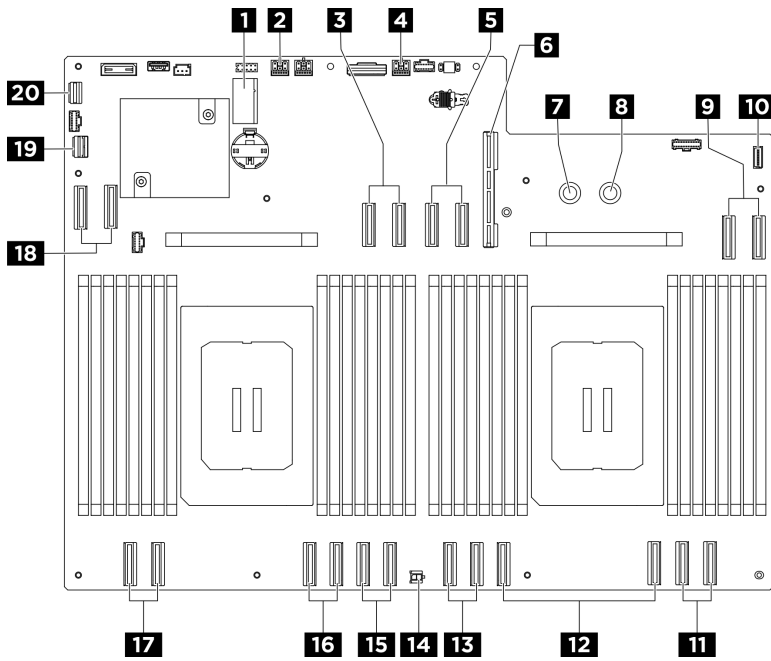

Figure 15. System board connectors

Table 17. System board connectors

| | |
|---|--|
| 1 M.2 slot 1 / M.2 slot 2 | 2 PCIe Riser 2 power and sideband connector |
| 3 MCIO connector 4 / PCIe Riser 2 signal connector / Rear drive backplane signal connector | 4 PCIe Riser 1 power and sideband connector |
| 5 MCIO connector 8 / PCIe Riser 1 signal connectors | 6 System I/O board connector (DC-SCM) |
| 7 PDB_0V connector (PSU_GND) | 8 PDB_P12V connector (PSU_P12V) |
| 9 MCIO connector 7 | 10 Integrated diagnostics panel connector |
| 11 MCIO connector 6 | 12 MCIO connector 5 |
| 13 MCIO connector 10 | 14 CPU leakage detection sensor connector |
| 15 MCIO connector 3 | 16 MCIO connector 2 |
| 17 MCIO connector 1 | 18 MCIO connector 9 |
| 19 PCIe switch sideband connector | 20 Front USB / Mini DisplayPort connector |

System board switches

The following illustration shows the location of the switches, jumpers, and buttons on the system board.

Note: If there is a clear protective sticker on the top of the switch blocks, you must remove and discard it to access the switches.

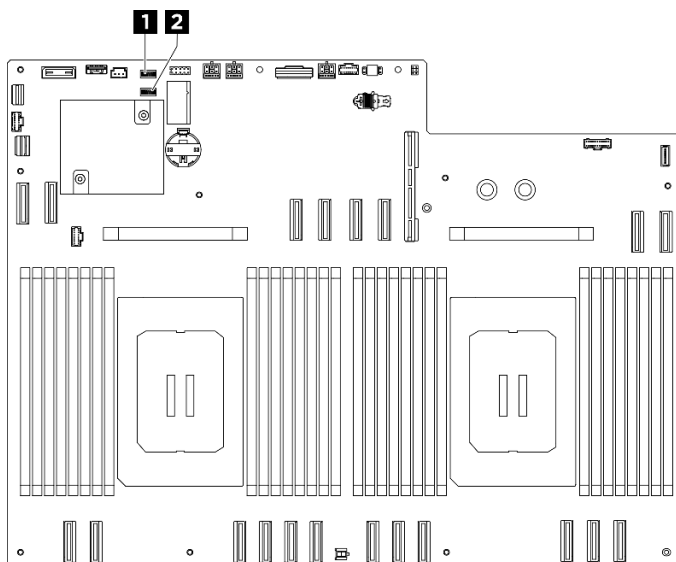

Figure 16. System board switches

Table 18. System board switches

| | |
|-------------------------------|-------------------------------|
| 1 Switch block 5 (SW5) | 2 Switch block 4 (SW4) |
|-------------------------------|-------------------------------|

Important:

- Before you change any switch settings or move any jumpers, turn off the server; then, disconnect all power cords and external cables. Review the following information:
 - https://pubs.lenovo.com/safety_documentation/
 - “Installation Guidelines”, “Handling static sensitive devices”, and “Power off the server ” in *User Guide* or *Hardware Maintenance Guide*.
- Any system-board-assembly switch or jumper block that is not shown in the illustrations in this document are reserved.

Switch block 5 (SW5)

The following table describes the functions of the switch block 5 (SW5) on the system board assembly.

Table 19. Switch block 5 (SW5) description

| Switch number | Switch name | Usage description | |
|---------------|---|--------------------------------|---|
| | | On | Off |
| 1 | XCC Trusted Platform Module (TPM) physical presence | Assert TPM physical presence | Normal (Default) |
| 2 | Flash security override | Enable flash security override | Disable flash security override (Default) |
| 3 | ME recovery | Enable ME boots to recovery | Normal (Default) |
| 4 | Reserved | | |
| 5 | Reserved | | |
| 6 | Reserved | | |

Table 19. Switch block 5 (SW5) description (continued)

| Switch number | Switch name | Usage description | |
|---------------|-------------|-------------------|-----|
| | | On | Off |
| 7 | Reserved | | |
| 8 | Reserved | | |

Switch block 4 (SW4)

The following table describes the functions of the switch block 4 (SW4) on the system board assembly.

Table 20. Switch block 4 (SW4) description

| Switch number | Switch name | Usage description | |
|---------------|-----------------------|--|-------------------|
| | | On | Off |
| 1 | BIOS recovery mode | Boot BIOS into recovery mode | Normal (Default) |
| 2 | Clear CMOS | Clear the real-time clock (RTC) registry | Normal (Default) |
| 3 | Password clear | Password clear | Normal (Default) |
| 4 | BIOS image swap | Enable BIOS image swap | Normal (Default) |
| 5 | PCH_TOP_SWAP_OVERRIDE | Swap | No swap (Default) |
| 6 | Reserved | | |
| 7 | Reserved | | |
| 8 | Reserved | | |

System I/O board connectors

The following illustration shows the internal connectors on the system I/O board.

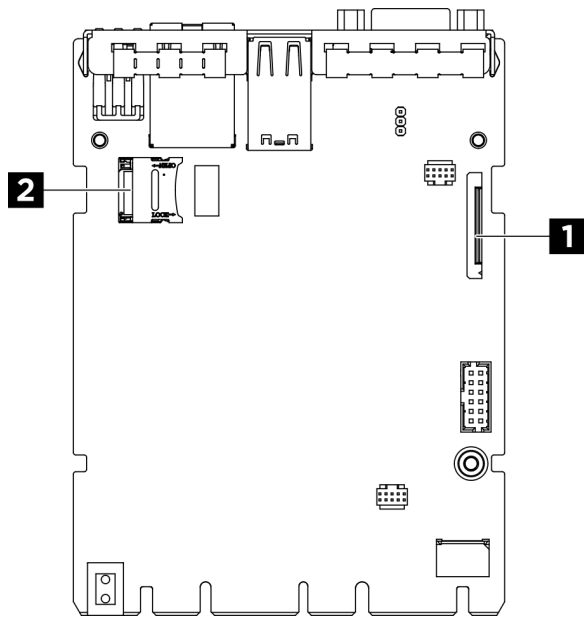

Figure 17. System I/O board connectors

Table 21. System-board-assembly connectors

| | |
|--|--------------------------------|
| <p>1 Second Lenovo XClarity Controller management connector (PHY2_CONN)</p> | <p>2 MicroSD socket</p> |
|--|--------------------------------|

System LEDs and diagnostics display

See the following section for information on available system LEDs and diagnostics display.

For more information, refer to [“Troubleshooting by system LEDs and diagnostics display” on page 31](#).

Troubleshooting by system LEDs and diagnostics display

See the following section for information on available system LEDs and diagnostics display.

Drive LEDs

This topic provides information on drive LEDs.

The following table describes the problems that are indicated by drive activity LED and drive status LED.

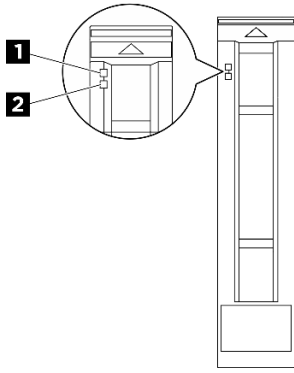

Figure 18. Drive LEDs

Table 22. Drive LEDs

| LED | Description |
|-------------------------------------|---|
| 1 Drive activity LED (green) | Each hot-swap drive comes with an activity LED. When this LED is flashing, it indicates that the drive is in use. |
| 2 Drive status LED (yellow) | The drive status LED indicates the following status: <ul style="list-style-type: none"> • The LED is lit: the drive has failed. • The LED is flashing slowly (once per second): the drive is being rebuilt. • The LED is flashing rapidly (three times per second): the drive is being identified. |

System I/O board LEDs

This topic provides information on LEDs of the system I/O board.

The following table describes the problems that are indicated by LEDs on the system I/O board.

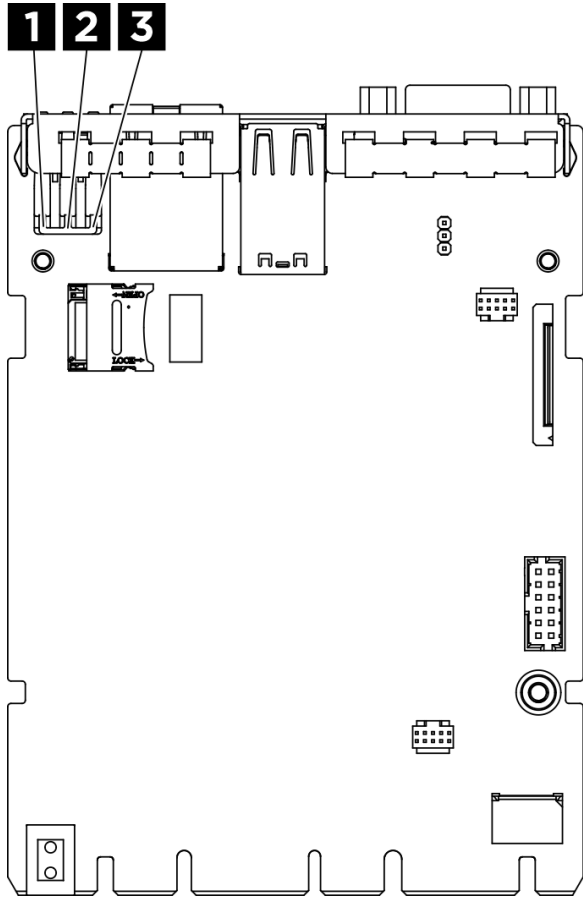

Figure 19. LEDs on the system I/O board

| | | |
|--------------------------------|------------------------------------|------------------------------|
| 1 RoT error LED (Amber) | 2 System error LED (yellow) | 3 Location LED (blue) |
|--------------------------------|------------------------------------|------------------------------|

Table 23. System LEDs on system I/O board

| LED | Description and actions |
|------------------------------------|---|
| 1 RoT error LED (Amber) | The RoT error LED indicates that there is a Root of Trust failure on either the XCC or UEFI image. |
| 2 System error LED (yellow) | LED on: an error has occurred. Complete the following steps: <ol style="list-style-type: none"> 1. Check the identification LED and check log LED and follow the instructions. 2. Check the Lenovo XClarity Controller event log and the system error log for information about the error. 3. Save the log if necessary, and clear the log afterwards. |
| 3 Location LED (blue) | This LED is used as a presence detection LED. You can use Lenovo XClarity Controller to light this LED remotely. Use this LED to locate the server among other servers visually. |

Power supply LEDs

This topic provides information about various power supply LED status and corresponding action suggestions.

The following minimal configuration is required for the server to start:

- Two processors
- Two memory modules
- One power supply
- One M.2 drive (If OS is needed by debugging)
- Six front fans
- Five rear fans
- One rear PCIe Ethernet Adapter (If network is required)
- CPU water loop connected to water (If connected to DC power)

The following table describes the problems that are indicated by various combinations of the power supply LEDs and the power-on LED and suggested actions to correct the detected problems.

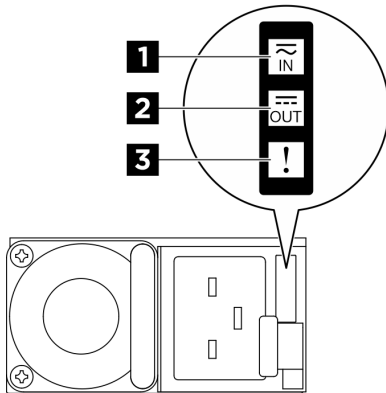

Figure 20. CFFv4 power supply LEDs

Table 24. CFFv4 power supply LEDs

| LED | Description |
|------------------------|--|
| 1 Input status | <p>The input status LED can be in one of the following states:</p> <ul style="list-style-type: none"> • Off: The power supply is disconnected from the AC power source. • Green: The power supply is connected to the AC power source. |
| 2 Output status | <p>The output status LED can be in one of the following states:</p> <ul style="list-style-type: none"> • Off: The server is powered off, or the power supply is not working properly. If the server is powered on but the output status LED is off, replace the power supply. • Slow blinking green (about one flash every two seconds): The power supply is in cold redundancy active mode. • Fast blinking green (about 2 flashes each second): The power supply is in cold redundancy sleep mode. • Green: The server is on and the power supply is working normally. |
| 3 Fault LED | <ul style="list-style-type: none"> • Off: The power supply is working normally • Amber: The power supply may have failed. Dump the FFDC log from the system and contact Lenovo back end support team for PSU data log reviewing. |

Rear system LEDs

This topic provides information on system LEDs on the rear of the server.

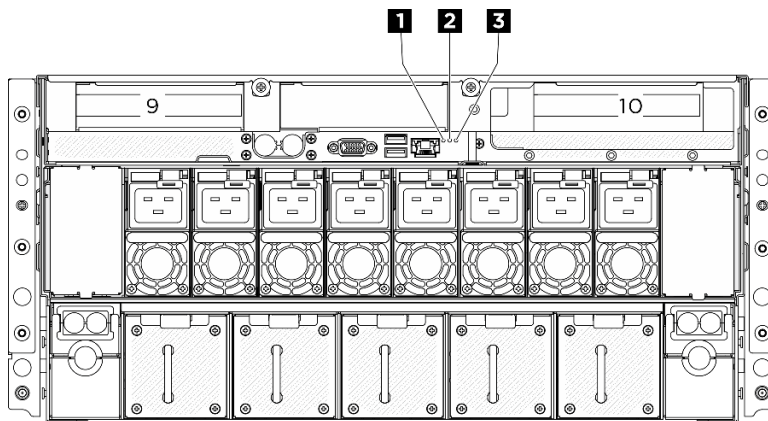

Figure 21. System LEDs on the rear view

| | | |
|------------------------------|------------------------------------|--------------------------------|
| 1 Location LED (blue) | 2 System error LED (yellow) | 3 RoT error LED (Amber) |
|------------------------------|------------------------------------|--------------------------------|

Table 25. System LEDs on the rear view

| LED | Description and actions |
|------------------------------------|---|
| 1 Location LED (blue) | This LED is used as a presence detection LED. You can use Lenovo XClarity Controller to light this LED remotely. Use this LED to locate the server among other servers visually. |
| 2 System error LED (yellow) | LED on: an error has occurred. Complete the following steps: <ol style="list-style-type: none"> 1. Check the identification LED and check log LED and follow the instructions. 2. Check the Lenovo XClarity Controller event log and the system error log for information about the error. 3. Save the log if necessary, and clear the log afterwards. |
| 3 RoT error LED (Amber) | The RoT error LED indicates that there is a Root of Trust failure on either the XCC or UEFI image. |

System board LEDs

The following illustrations show the light-emitting diodes (LEDs) on the system board.

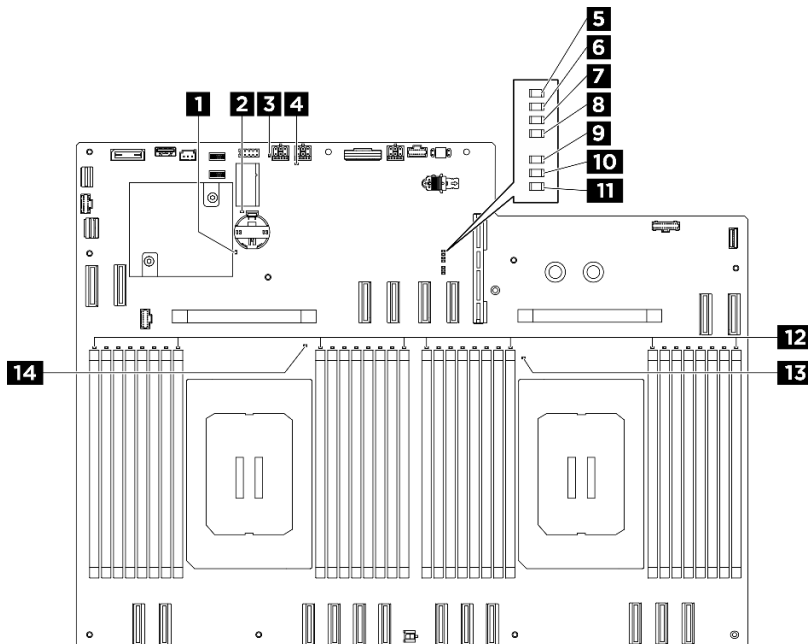

Figure 22. System board LEDs

Table 26. System board LEDs

| LED | Description and actions |
|--|--|
| 1 ME heartbeat LED (green) | <ul style="list-style-type: none"> • Blinking (about one flash per second): System normal. • off: System fault occurred. |
| 2 CMOS battery error LED (yellow) | The system CMOS battery is not installed or is not working. |

Table 26. System board LEDs (continued)

| LED | Description and actions |
|--|--|
| 3 M.2 slot 1 activity LED (green) | <ul style="list-style-type: none"> On: M.2 Slot 1 active. Off: M.2 Slot 1 not active. |
| 4 M.2 slot 2 activity LED (green) | <ul style="list-style-type: none"> On: M.2 Slot 2 active. Off: M.2 Slot 2 not active. |
| 5 P5V_AUX PGOOD LED (green) | <ul style="list-style-type: none"> On: P5V_AUX power is present. Off: P5V_AUX is not ready. |
| 6 FPGA heartbeat LED (green) | <ul style="list-style-type: none"> Blinking (about one flash per second): FPGA is working normally. If FPGA heartbeat LED is always off or always on, do the following: <ol style="list-style-type: none"> Replace the processor board. If the problem remains, contact Lenovo Support. |
| 7 P12V PGOOD LED (green) | Indicates the system is DC on. |
| 8 System power LED (green) | <p>The states of the power LED are as follows:</p> <ul style="list-style-type: none"> Off: No power supply is properly installed, or the LED itself has failed. Flashing rapidly (four times per second): The server is turned off and is not ready to be turned on. The power-control button is disabled. This will last approximately 5 to 10 seconds. Flashing slowly (once per second): The server is turned off and is ready to be turned on. You can press the power-control button to turn on the server. Lit: The server is turned on. |
| 9 NMI error LED (amber) | Indicates that the system had an NMI (Non Maskable Interrupt). |
| 10 Processor mismatch LED (amber) | Indicates that processors are not matched. |
| 11 System-board-assembly error LED (yellow) | <p>LED on: an error has occurred to the system board assembly. Complete the following steps:</p> <ol style="list-style-type: none"> Check the Lenovo XClarity Controller event log and the system error log for information about the error. Save the log if necessary, and clear the log afterward. |
| 12 DIMM error LEDs (1-32) (amber) | <ul style="list-style-type: none"> LED on: an error has occurred to the DIMM the LED represents. For more information, see “Memory problems” in the <i>User Guide</i>. |
| 13 Processor 1 error LED (amber) | LED on: an error has occurred to the processor the LED represents. Replace the processor. |
| 14 Processor 0 error LED (amber) | LED on: an error has occurred to the processor the LED represents. Replace the processor. |

XCC system management port LEDs

This topic provides information on LEDs of XCC system management port (10/100/1000 Mbps RJ-45).

The following table describes the problems that are indicated by LEDs on XCC system management port (10/100/1000 Mbps RJ-45).

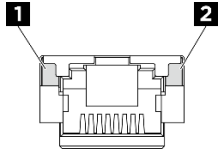

Figure 23. XCC system management port (10/100/1000 Mbps RJ-45) LEDs

Table 27. XCC system management port (10/100/1000 Mbps RJ-45) LEDs

| LED | Description |
|---|---|
| 1 XCC system management port (10/100/1000 Mbps RJ-45) link LED | Use this green LED to distinguish the network connectivity status: <ul style="list-style-type: none"> • Off: The network link is disconnected. • Green: The network link is established. |
| 2 XCC system management port (10/100/1000 Mbps RJ-45) activity LED | Use this green LED to distinguish the network activity status: <ul style="list-style-type: none"> • Off: The server is disconnected from a LAN. • Green: The network is connected and active. |

Integrated diagnostics panel

The Integrated diagnostics panel is attached to the front of the server, while it allows quick access to system information such as errors, system status, firmware, network, and health information. The Integrated Diagnostics Panel may also provide front operator panel function.

Location of the integrated diagnostics panel

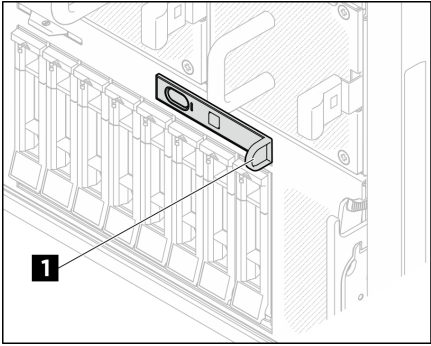
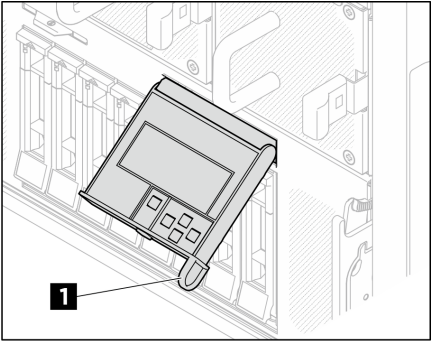
| | |
|-----------------|---|
| Location | <p>The integrated diagnostics panel is attached to the front of the 8U GPU shuttle.</p> <div style="display: flex; justify-content: space-around;">   </div> |
| Callout | <p>1 The handle with which the panel can be pulled out from the server.</p> <p>Notes:</p> <ul style="list-style-type: none"> • The panel can be pushed in or pulled out regardless of the system power status. • When pulling it out, do it gently to avoid damage. |

Display panel overview

The diagnostics device consists of an LCD display and 5 navigation buttons.

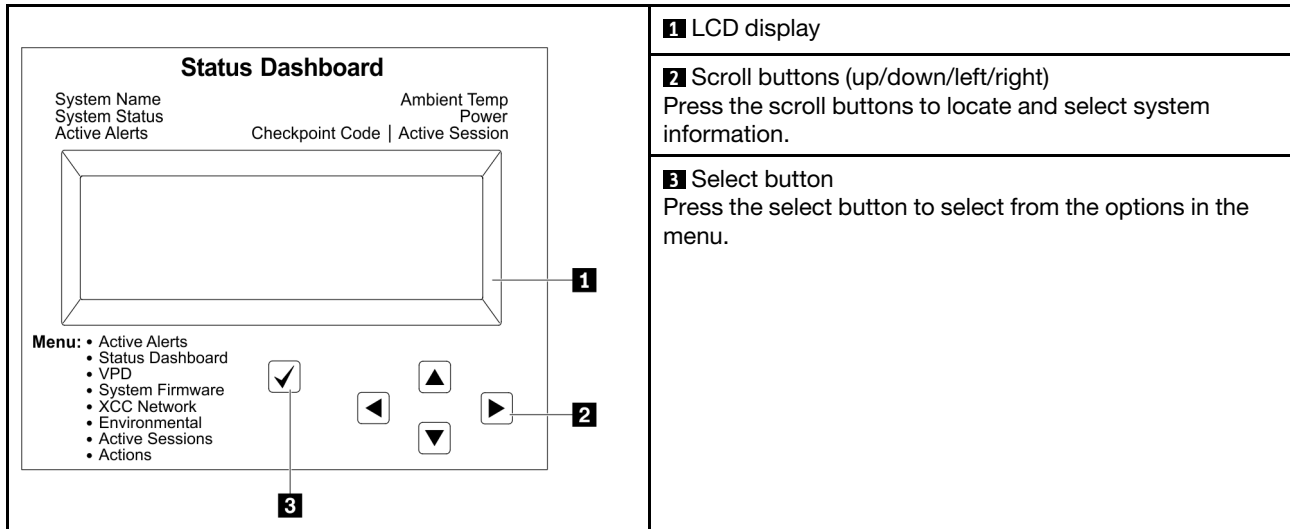

Option flow diagram

The LCD panel displays various system information. Navigate through the options with the scroll keys.

Depending on the model, the options and entries on the LCD display might be different.

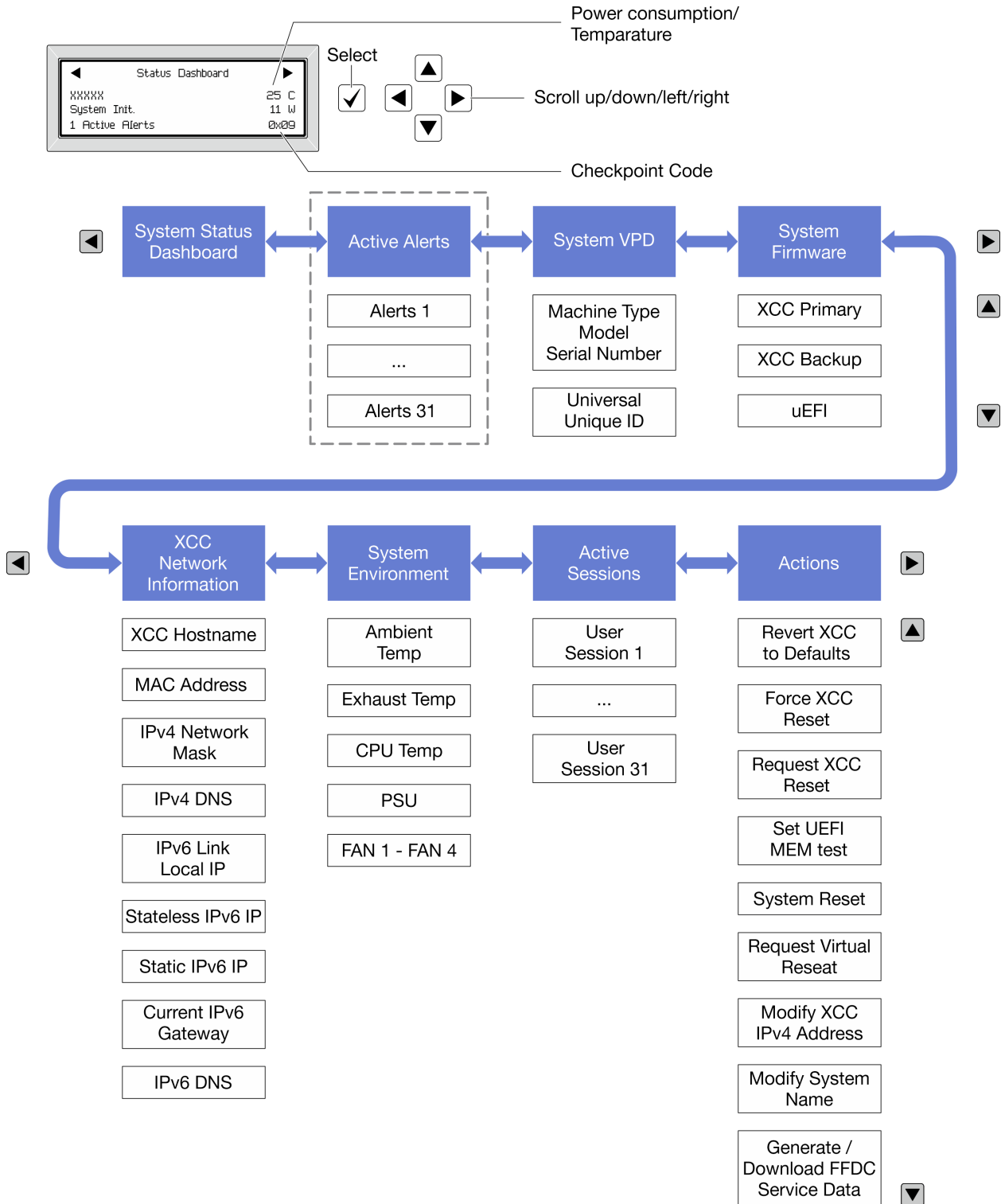

Full menu list

Following is the list of available options. Switch between an option and the subordinate information entries with the select button, and switch among options or information entries with the scroll buttons.

Depending on the model, the options and entries on the LCD display might be different.

Home Menu (System Status Dashboard)

| Home Menu | Example |
|--|--|
| <ul style="list-style-type: none"> 1 System name 2 System status 3 Active alert quantity 4 Temperature 5 Power consumption 6 Checkpoint code | <p>The screenshot shows a 'Status Dashboard' screen with the following items: 'xxxxxx' (1), 'System Init.' (2), '1 Active Alerts' (3), '25 C' (4), '11 W' (5), and '0x09' (6). Navigation arrows are visible at the top.</p> |

Active Alerts

| Sub Menu | Example |
|---|---|
| Home screen: Active error quantity Note: The "Active Alerts" menu displays only the quantity of active errors. If no errors occur, the "Active Alerts" menu will not be available during navigation. | 1 Active Alerts |
| Details screen: <ul style="list-style-type: none"> • Error message ID (Type: Error/Warning/Information) • Occurrence time • Possible sources of the error | Active Alerts: 1 Press ▼ to view alert details FQXSPPU009N(Error) 04/07/2020 02:37:39 PM CPU 1 Status: Configuration Error |

System VPD Information

| Sub Menu | Example |
|--|--|
| <ul style="list-style-type: none"> • Machine type and serial number • Universal Unique ID (UUID) | Machine Type: xxxx Serial Num: xxxxxx Universal Unique ID: xxxxxxxxxxxxxxxxxxxxxxxxxxxxxxxx |

System Firmware

| Sub Menu | Example |
|---|---|
| XCC Primary <ul style="list-style-type: none"> Firmware level (status) Build ID Version number Release date | XCC Primary (Active) Build: DVI399T Version: 4.07 Date: 2020-04-07 |
| XCC Backup <ul style="list-style-type: none"> Firmware level (status) Build ID Version number Release date | XCC Backup (Active) Build: D8BT05I Version: 1.00 Date: 2019-12-30 |
| UEFI <ul style="list-style-type: none"> Firmware level (status) Build ID Version number Release date | UEFI (Inactive) Build: DOE101P Version: 1.00 Date: 2019-12-26 |

XCC Network Information

| Sub Menu | Example |
|---|---|
| <ul style="list-style-type: none"> XCC hostname MAC address IPv4 Network Mask IPv4 DNS IPv6 Link Local IP Stateless IPv6 IP Static IPv6 IP Current IPv6 Gateway IPv6 DNS <p>Note: Only the MAC address that is currently in use is displayed (extension or shared).</p> | XCC Network Information XCC Hostname: XCC-xxxx-SN MAC Address: xx:xx:xx:xx:xx:xx IPv4 IP: xx.xx.xx.xx IPv4 Network Mask: x.x.x.x IPv4 Default Gateway: x.x.x.x |

System Environmental Information

| Sub Menu | Example |
|--|--|
| <ul style="list-style-type: none"> • Ambient temperature • Exhaust temperature • CPU temperature • PSU status • Spinning speed of fans by RPM | Ambient Temp: 24 C Exhaust Temp: 30 C CPU1 Temp: 50 C PSU1: Vin= 213 w Inlet= 26 C FAN1 Front: 21000 RPM FAN2 Front: 21000 RPM FAN3 Front: 21000 RPM FAN4 Front: 21000 RPM |

Active Sessions

| Sub Menu | Example |
|-----------------------------|-------------------------|
| Quantity of active sessions | Active User Sessions: 1 |

Actions

| Sub Menu | Example |
|---|---|
| Several quick actions are available: <ul style="list-style-type: none"> • Revert XCC to Defaults • Force XCC Reset • Request XCC Reset • Set UEFI Memory Test • Request Virtual Reseat • Modify XCC Static IPv4 Address/Net mask/Gateway • Modify System Name • Generate/Download FFDC Service Data | Request XCC Reset? This will request the BMC to reboot itself. Hold <input checked="" type="checkbox"/> for 3 seconds |

leakage sensor module LED

This topic provides information about the LED on the leakage detection sensor module.

The leakage sensor module on the GPU cold plate module and Direct Water Cooling Module (DWCM) comes with one LED. The following illustration shows the LED on the module.

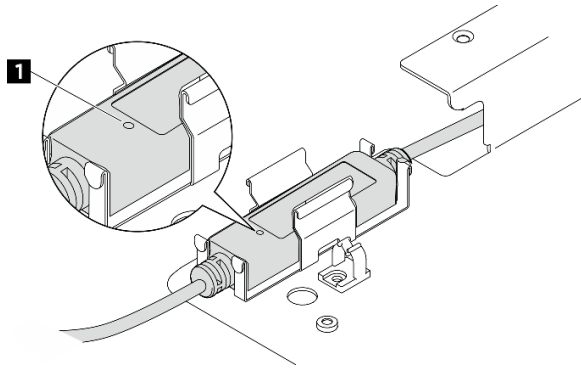

Figure 24. Leak detection LED

The following table describes the status that are indicated by the leakage sensor module LED.

| 1 leakage sensor module LED | |
|------------------------------------|--|
| Description | <ul style="list-style-type: none"> • Solid green: No coolant leakage detected. • Blinking green: Abnormal status detected. |
| Action | See water leakage problem determination and troubleshooting. |

Chapter 3. Parts list

Identify each of the components that is available for your server with the parts list.

For more information about ordering parts:

1. Go to <http://datacentersupport.lenovo.com> and navigate to the support page for your server.
2. Click **Parts**.
3. Enter the serial number to view a listing of parts for your server.

It is highly recommended that you check the power summary data for your server using Lenovo Capacity Planner before purchasing any new parts.

Note: Depending on the model, your server might look slightly different from the illustration.

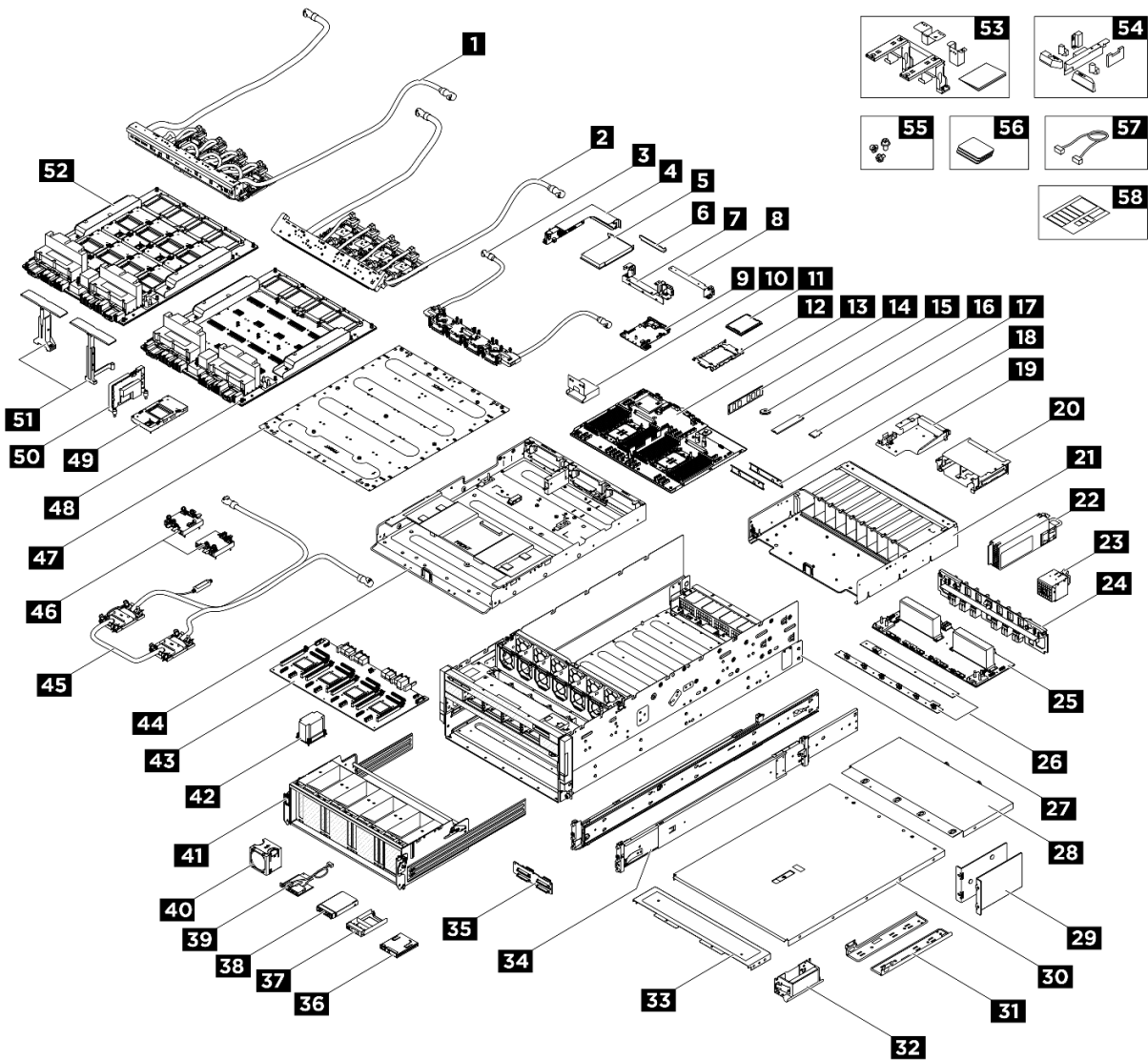

Figure 25. Server components

The parts listed in the following table are identified as one of the following:

- **T1:** Tier 1 customer replaceable unit (CRU). Replacement of Tier 1 CRUs is your responsibility. If Lenovo installs a Tier 1 CRU at your request with no service agreement, you will be charged for the installation.
- **T2:** Tier 2 customer replaceable unit (CRU). You may install a Tier 2 CRU yourself or request Lenovo to install it, at no additional charge, under the type of warranty service that is designated for your server.
- **F:** Field replaceable unit (FRU). FRUs must be installed only by trained service technicians.
- **C:** Consumable and Structural parts. Purchase and replacement of consumable and structural parts (components, such as a filler or bezel) is your responsibility. If Lenovo acquires or installs a structural component at your request, you will be charged for the service.

Table 28. Parts list

| Index | Description | Type |
|--|---------------------------------------|------|
| <p>For more information about ordering parts:</p> <ol style="list-style-type: none"> 1. Go to http://datacentersupport.lenovo.com and navigate to the support page for your server. 2. Click Parts. 3. Enter the serial number to view a listing of parts for your server. | | |
| 1 | Front H100/H200 GPU cold plate module | F |
| 2 | Rear H100/H200 GPU cold plate module | F |
| 3 | NVSwitch cold plate module | F |
| 4 | PCIe riser | F |
| 5 | PCIe adapter | F |
| 6 | PCIe filler (single-slot) | F |
| 7 | Rear drive cage support bracket | F |
| 8 | PCIe riser support bracket | F |
| 9 | System I/O board | F |
| 10 | GPU cable holder | F |
| 11 | Processor | F |
| 12 | Processor carrier | F |
| 13 | System board | F |
| 14 | Memory module | T1 |
| 15 | CMOS battery | C |
| 16 | M.2 drive | F |
| 17 | MicroSD card | F |
| 18 | Venting block | F |
| 19 | Leakage sensor module bracket | F |
| 20 | Rear drive cage | F |
| 21 | PSU cage | F |
| 22 | Power supply unit | T1 |
| 23 | Rear fan | T1 |
| 24 | PSU interposer | F |
| 25 | Power distribution board | F |
| 26 | Fan control board | F |
| 27 | Chassis | F |
| 28 | Rear top cover | T1 |
| 29 | Shipping bracket | T1 |
| 30 | Front top cover | T1 |
| 31 | Hose guide | F |

Table 28. Parts list (continued)

| Index | Description | Type |
|-------|--|------|
| 32 | Chassis lift handle | F |
| 33 | I/O cover | F |
| 34 | Slide rail kit | F |
| 35 | 2.5-inch drive backplane | F |
| 36 | Integrated diagnostics panel | F |
| 37 | 2.5-inch drive filler (1-bay) | T1 |
| 38 | 2.5-inch hot-swap drive | T1 |
| 39 | Front I/O module | F |
| 40 | Front fan | T1 |
| 41 | PCIe switch shuttle | F |
| 42 | PCIe switch board heat sink | F |
| 43 | PCIe switch board | F |
| 44 | CPU complex tray | F |
| 45 | Lenovo Neptune Processor Direct Water Cooling Module | F |
| 46 | Cold plate cover | F |
| 47 | GPU baseboard adapter | F |
| 48 | GPU baseboard | F |
| 49 | GPU | F |
| 50 | HMC card | F |
| 51 | GPU baseboard handle | F |
| 52 | GPU complex | F |
| 53 | GPU water loop Service Kit | F |
| 54 | DPU air baffle | F |
| 55 | Screw | F |
| 56 | PCM / putty pad kit | F |
| 57 | External cable | T1 |
| | Internal cable | F |
| 58 | Label sheet | F |

Power cords

Several power cords are available, depending on the country and region where the server is installed.

To view the power cords that are available for the server:

1. Go to:

<http://dcsc.lenovo.com/#/>

2. Click **Preconfigured Model** or **Configure to order**.

3. Enter the machine type and model for your server to display the configurator page.
4. Click **Power** → **Power Cables** to see all line cords.

Notes:

- For your safety, a power cord with a grounded attachment plug is provided to use with this product. To avoid electrical shock, always use the power cord and plug with a properly grounded outlet.
- Power cords for this product that are used in the United States and Canada are listed by Underwriter's Laboratories (UL) and certified by the Canadian Standards Association (CSA).
- For units intended to be operated at 115 volts: Use a UL-listed and CSA-certified cord set consisting of a minimum 18 AWG, Type SVT or SJT, three-conductor cord, a maximum of 15 feet in length and a parallel blade, grounding-type attachment plug rated 15 amperes, 125 volts.
- For units intended to be operated at 230 volts (U.S. use): Use a UL-listed and CSA-certified cord set consisting of a minimum 18 AWG, Type SVT or SJT, three-conductor cord, a maximum of 15 feet in length and a tandem blade, grounding-type attachment plug rated 15 amperes, 250 volts.
- For units intended to be operated at 230 volts (outside the U.S.): Use a cord set with a grounding-type attachment plug. The cord set should have the appropriate safety approvals for the country in which the equipment will be installed.
- Power cords for a specific country or region are usually available only in that country or region.

Chapter 4. Unboxing and setup

Information in this section assists you on unboxing and setting up the server. When unboxing the server, check if the items in the package are correct, and learn where to find information of server serial number and Lenovo XClarity Controller access. Make sure to follow the instructions in “[Server setup checklist](#)” on [page 55](#) when setting up the server.

Attention: Two people and one lifting device on site that can support up to 400 lb (181 kg) are required to perform the replacement procedure of certain parts. If you do not already have a lifting device available, Lenovo offers the Genie Lift GL-8 material lift that can be purchased at Data Center Solution Configurator: <https://dcsc.lenovo.com/#/configuration/cto/7D5YCTO1WW?hardwareType=lifttool>. Make sure to include the Foot-release brake and the Load Platform when ordering the Genie Lift GL-8 material lift.

Server package contents

When you receive your server, verify that the shipment contains everything that you expected to receive.

The server package includes the following items:

- Server
- Rail installation kit*. Installation guide is provided in the package.
- Material box, including items such as power cords*, accessory kit, and printed documents.

Notes:

- Some of the items listed are available on select models only.
- Items marked with asterisk(*) are optional.

If any item is missing or damaged, contact your place of purchase. Ensure that you retain your proof of purchase and packing material. They might be required to receive warranty service.

Identify the server and access the Lenovo XClarity Controller

This section contains instruction on how to identify your server and where to find the Lenovo XClarity Controller access information.

Identifying your server

When you contact Lenovo for help, the machine type, model, and serial number information help support technicians to identify your server and provide faster service.

The illustration below shows the location of the ID label which contains the model number, machine type, and serial number of the server. You can also add other system information labels to the front of the server in the customer label spaces.

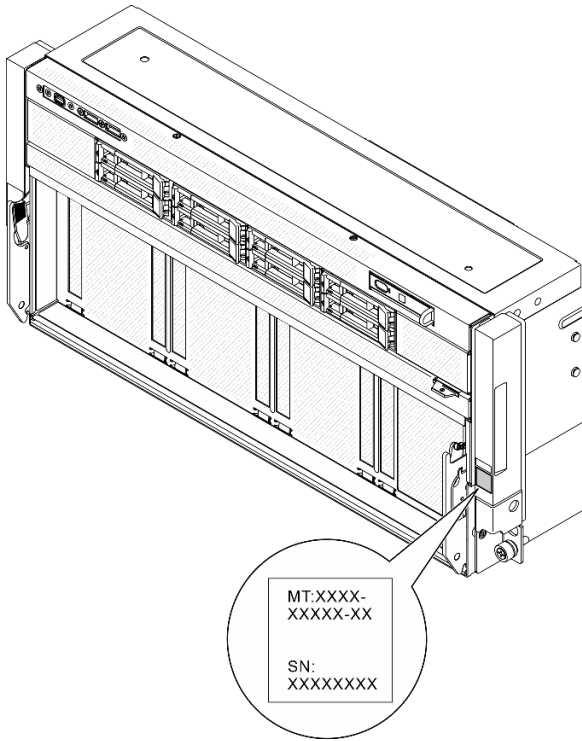

Figure 26. Location of the ID label

Lenovo XClarity Controller network access label

In addition, the Lenovo XClarity Controller network access label is attached to the pull-out information tab located near the integrated diagnostics panel in the front of the chassis, with MAC address accessible with a pull.

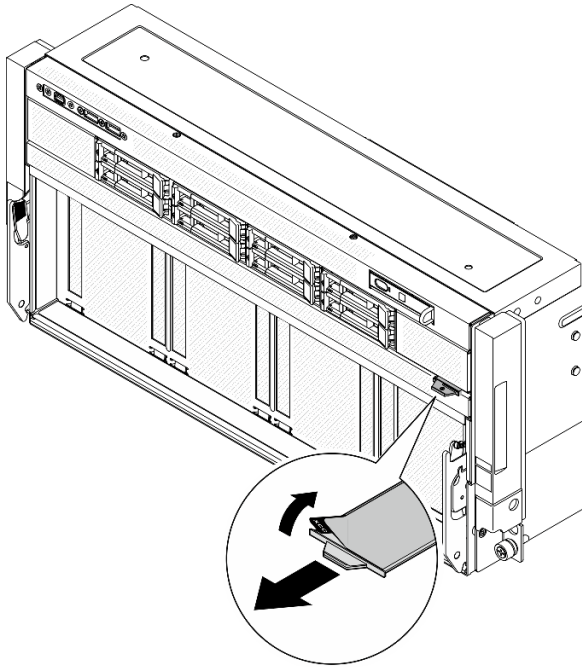

Figure 27. Lenovo XClarity Controller network access label on the pull-out information tab

Service Label and QR code

In addition, the system Service Label is located on the surface of the processor air baffle, provides a quick reference (QR) code for mobile access to service information. You can scan the QR code with a mobile device using a QR code reader application and get quick access to the Service Information web page. The Service Information web page provides additional information for parts installation and replacement videos, and error codes for solution support.

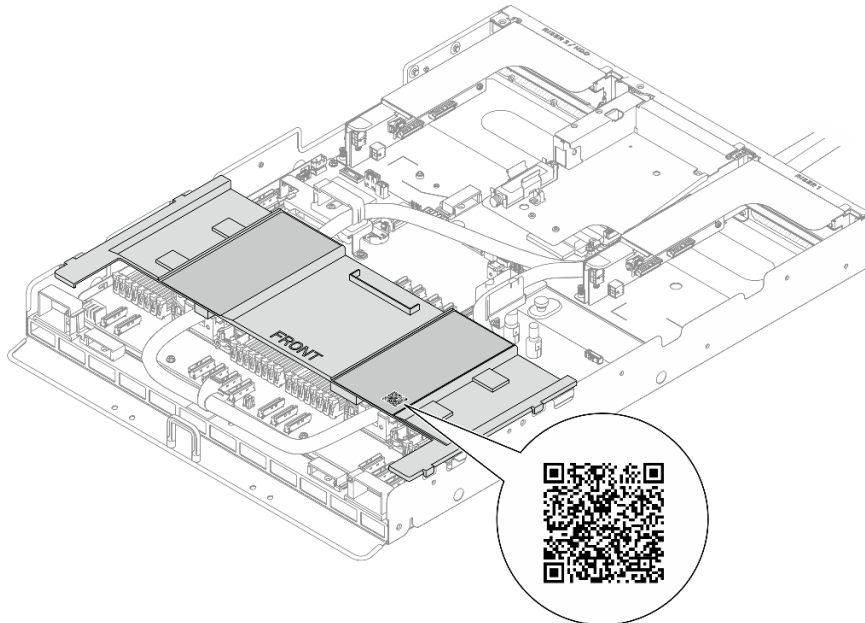

Figure 28. Service Label and QR code

Server setup checklist

Use the server setup checklist to ensure that you have performed all tasks that are required to set up your server.

The server setup procedure varies depending on the configuration of the server when it was delivered. In some cases, the server is fully configured and you just need to connect the server to the network and an AC power source, and then you can power on the server. In other cases, the server needs to have hardware options installed, requires hardware and firmware configuration, and requires an operating system to be installed.

The following steps describe the general procedure for setting up a server.

Setup the server hardware

Complete the following procedures to setup the server hardware.

Attention: Two people and one lifting device on site that can support up to 400 lb (181 kg) are required to perform the replacement procedure of certain parts. If you do not already have a lifting device available, Lenovo offers the Genie Lift GL-8 material lift that can be purchased at Data Center Solution Configurator: <https://dcsc.lenovo.com/#/configuration/cto/7D5YCTO1WW?hardwareType=lifttool>. Make sure to include the Foot-release brake and the Load Platform when ordering the Genie Lift GL-8 material lift.

1. Unpack the server package. See “[Server package contents](#)” on page 53.
2. Install any required hardware or server options. See the related topics in “Hardware replacement procedures” in *User Guide* or *Hardware Maintenance Guide*.

3. If necessary, install the rail to a standard rack cabinet. Follow the instruction in *Rail Installation Guide* that comes with the rail installation kit.
4. If necessary, install the chassis into a standard rack cabinet. See “Install the chassis to rack” in *User Guide* or *Hardware Maintenance Guide*.
5. Connect all external cables to the server. See [Chapter 2 “Server components” on page 13](#) for connectors locations.

Typically, you will need to connect the following cables:

- Connect server to the power source
 - Connect server to the data network
 - Connect the server to the storage device
 - Connect the server to the management network
6. Power on the server.

Power button location and power LED are specified in:

- [Chapter 2 “Server components” on page 13](#)
- [“Troubleshooting by system LEDs and diagnostics display” on page 31](#)

The server can be turned on (power LED on) in any of the following ways:

- You can press the power button.
- The server can restart automatically after a power interruption.
- The server can respond to remote power-on requests sent to the Lenovo XClarity Controller.

Note: You can access the management processor interface to configure the system without powering on the server. Whenever the server is connected to power, the management processor interface is available. For details about accessing the management server processor, see “Opening and Using the XClarity Controller Web Interface” section in the XCC documentation compatible with your server at <https://pubs.lenovo.com/lxcc-overview/>.

7. Validate the server. Make sure that the power LED, Ethernet connector LED, and network LED are lit with green light, which means the server hardware was set up successfully.

See [“System LEDs and diagnostics display” on page 31](#) for more information on the LED indications.

Configure the system

Complete the following procedures to configure the system. For detailed instructions, refer to [Chapter 5 “System configuration” on page 57](#).

1. Set the network connection for the Lenovo XClarity Controller to the management network.
2. Update the firmware for the server, if necessary.
3. Configure the firmware for the server.

The following information is available for RAID configuration:

- <https://lenovopress.lenovo.com/lp0578-lenovo-raid-introduction>
 - <https://lenovopress.lenovo.com/lp0579-lenovo-raid-management-tools-and-resources>
4. Install the operating system.
 5. Back up the server configuration.
 6. Install the applications and programs for which the server is intended to be used.

Chapter 5. System configuration

Complete these procedures to configure your system.

Set the network connection for the Lenovo XClarity Controller

Before you can access the Lenovo XClarity Controller over your network, you need to specify how Lenovo XClarity Controller will connect to the network. Depending on how the network connection is implemented, you might need to specify a static IP address as well.

The following methods are available to set the network connection for the Lenovo XClarity Controller if you are not using DHCP:

- If a monitor is attached to the server, you can use Lenovo XClarity Provisioning Manager to set the network connection.

Complete the following steps to connect the Lenovo XClarity Controller to the network using the Lenovo XClarity Provisioning Manager.

1. Start the server.
2. Press the key specified in the on-screen instructions to display the Lenovo XClarity Provisioning Manager interface. (For more information, see the “Startup” section in the LXPM documentation compatible with your server at <https://pubs.lenovo.com/lxpm-overview/>.)
3. Go to **LXPM → UEFI Setup → BMC Settings** to specify how the Lenovo XClarity Controller will connect to the network.
 - If you choose a static IP connection, make sure that you specify an IPv4 or IPv6 address that is available on the network.
 - If you choose a DHCP connection, make sure that the MAC address for the server has been configured in the DHCP server.
4. Click **OK** to apply the setting and wait for two to three minutes.
5. Use an IPv4 or IPv6 address to connect Lenovo XClarity Controller.

Important: The Lenovo XClarity Controller is set initially with a user name of USERID and password of PASSW0RD (with a zero, not the letter O). This default user setting has Supervisor access. It is required to change this user name and password during your initial configuration for enhanced security.

- If no monitor is attached to the server, you can set the network connection through the Lenovo XClarity Controller interface. Connect an Ethernet cable from your laptop to XCC system management port (10/100/1000 Mbps RJ-45) on your server. For the location of the XCC system management port (10/100/1000 Mbps RJ-45), see [Chapter 2 “Server components” on page 13](#).

Note: Make sure that you modify the IP settings on the laptop so that it is on the same network as the server default settings.

The default IPv4 address and the IPv6 Link Local Address (LLA) is provided on the Lenovo XClarity Controller Network Access label that is affixed to the Pull Out Information Tab. See [“Identify the server and access the Lenovo XClarity Controller” on page 53](#).

- If you are using the Lenovo XClarity Administrator Mobile app from a mobile device, you can connect to the Lenovo XClarity Controller through the Lenovo XClarity Controller USB connector on the server. For the location of the Lenovo XClarity Controller USB connector, see [Chapter 2 “Server components” on page 13](#).

Note: The Lenovo XClarity Controller USB connector mode must be set to manage the Lenovo XClarity Controller (instead of normal USB mode). To switch from normal mode to Lenovo XClarity Controller management mode, hold the ID button on the server for at least 3 seconds until its LED flashes slowly (once every couple of seconds). See [Chapter 2 “Server components” on page 13](#) for the location of the ID button.

To connect using the Lenovo XClarity Administrator Mobile app:

1. Connect the USB cable of your mobile device to the Lenovo XClarity Controller USB connector on the server.
2. On your mobile device, enable USB tethering.
3. On your mobile device, launch the Lenovo XClarity Administrator mobile app.
4. If automatic discovery is disabled, click **Discovery** on the USB Discovery page to connect to the Lenovo XClarity Controller.

For more information about using the Lenovo XClarity Administrator Mobile app, see:

https://pubs.lenovo.com/lxca/lxca_usemobileapp

Set USB port for Lenovo XClarity Controller connection

Before you can access the Lenovo XClarity Controller through the USB port, you need to configure the USB port for Lenovo XClarity Controller connection.

Server support

To see if your server supports accessing Lenovo XClarity Controller through the USB port, check one of the following:

- Refer to [Chapter 2 “Server components” on page 13](#).



- If there is a wrench icon on the USB port of your server, you can set the management USB port to connect to Lenovo XClarity Controller. It is also the only USB port that supports USB automation update of the system I/O board (or firmware and RoT security module).

Setting the USB port for Lenovo XClarity Controller connection

You can switch the USB port between normal and Lenovo XClarity Controller management operation by performing one of the following steps.

- Hold the ID button for at least 3 seconds until its LED flashes slowly (once every couple of seconds). See [Chapter 2 “Server components” on page 13](#) for ID button location.
- From the Lenovo XClarity Controller management controller CLI, run the `usbfp` command. For information about using the Lenovo XClarity Controller CLI, see the “Command-line interface” section in the XCC documentation compatible with your server at <https://pubs.lenovo.com/lxcc-overview/>.
- From the Lenovo XClarity Controller management controller web interface, click **BMC Configuration → Network → USB Management Port Assignment**. For information about Lenovo XClarity Controller web interface functions, see the “Description of XClarity Controller functions on web interface” section in the XCC documentation compatible with your server at <https://pubs.lenovo.com/lxcc-overview/>.

Checking USB port current setting

You can also check the current setting of the USB port using the Lenovo XClarity Controller management controller CLI (`usbfp` command) or the Lenovo XClarity Controller management controller web interface (**BMC Configuration → Network → USB Management Port Assignment**). See the “Command-line

interface” and “Description of XClarity Controller functions on web interface” sections in the XCC documentation compatible with your server at <https://pubs.lenovo.com/lxcc-overview/>.

Update the firmware

Several options are available to update the firmware for the server.

You can use the tools listed here to update the most current firmware for your server and the devices that are installed in the server.

- Best practices related to updating firmware is available at the following site:
 - <https://lenovopress.lenovo.com/lp0656-lenovo-thinksystem-firmware-and-driver-update-best-practices>
- The latest firmware can be found at the following site:
 - <https://datacentersupport.lenovo.com/tw/en/products/servers/thinksystem/sr780av3/7dj5/downloads/driver-list/>
- You can subscribe to product notification to stay up to date on firmware updates:
 - <https://datacentersupport.lenovo.com/solutions/ht509500>

Update Bundles (Service Packs)

Lenovo typically releases firmware in bundles called Update Bundles (Service Packs). To ensure that all of the firmware updates are compatible, you should update all firmware at the same time. If you are updating firmware for both the Lenovo XClarity Controller and UEFI, update the firmware for Lenovo XClarity Controller first.

Update method terminology

- **In-band update.** The installation or update is performed using a tool or application within an operating system that is executing on the server’s core CPU.
- **Out-of-band update.** The installation or update is performed by the Lenovo XClarity Controller collecting the update and then directing the update to the target subsystem or device. Out-of-band updates have no dependency on an operating system executing on the core CPU. However, most out-of-band operations do require the server to be in the S0 (Working) power state.
- **On-Target update.** The installation or update is initiated from an installed operating system executing on the target server itself.
- **Off-Target update.** The installation or update is initiated from a computing device interacting directly with the server’s Lenovo XClarity Controller.
- **Update Bundles (Service Packs).** Update Bundles (Service Packs) are bundled updates designed and tested to provide the interdependent level of functionality, performance, and compatibility. Update Bundles (Service Packs) are server machine-type specific and are built (with firmware and device driver updates) to support specific Windows Server, Red Hat Enterprise Linux (RHEL) and SUSE Linux Enterprise Server (SLES) operating system distributions. Machine-type-specific firmware-only Update Bundles (Service Packs) are also available.

Firmware updating tools

See the following table to determine the best Lenovo tool to use for installing and setting up the firmware:

| Tool | Update Methods Supported | Core System Firmware Updates | I/O Devices Firmware Updates | Drive Firmware Updates | Graphical user interface | Command line interface | Supports Update Bundles (Service Packs) |
|---|--|------------------------------|------------------------------|------------------------|--------------------------|------------------------|---|
| Lenovo XClarity Provisioning Manager (LXPM) | In-band ² On-Target | √ | | | √ | | |
| Lenovo XClarity Controller (XCC) | In-band ⁴ Out-of-band Off-Target | √ | Selected I/O devices | √ ³ | √ | | √ |
| Lenovo XClarity Essentials OneCLI (OneCLI) | In-band Out-of-band On-Target Off-Target | √ | All I/O devices | √ ³ | | √ | √ |
| Lenovo XClarity Essentials UpdateXpress (LXCE) | In-band Out-of-band On-Target Off-Target | √ | All I/O devices | | √ | | √ |
| Lenovo XClarity Essentials Bootable Media Creator (BoMC) | In-band Out-of-band Off-Target | √ | All I/O devices | | √ (BoMC application) | √ (BoMC application) | √ |
| Lenovo XClarity Administrator (LXCA) | In-band ¹ Out-of-band ² Off-Target | √ | All I/O devices | | √ | | √ |
| Lenovo XClarity Integrator (LXCI) for VMware vCenter | Out-of-band Off-Target | √ | Selected I/O devices | | √ | | |
| Lenovo XClarity Integrator (LXCI) for Microsoft Windows Admin Center | In-band Out-of-band On-Target Off-Target | √ | All I/O devices | | √ | | √ |

| Tool | Update Methods Supported | Core System Firmware Updates | I/O Devices Firmware Updates | Drive Firmware Updates | Graphical user interface | Command line interface | Supports Update Bundles (Service Packs) |
|---|--------------------------|------------------------------|------------------------------|------------------------|--------------------------|------------------------|---|
| Lenovo XClarity Integrator (LXCI) for Microsoft System Center Configuration Manager | In-band On-Target | √ | All I/O devices | | √ | | √ |
| Notes: <ol style="list-style-type: none"> For I/O firmware updates. For BMC and UEFI firmware updates. Drive firmware update is only supported by the tools and methods below: <ul style="list-style-type: none"> XCC Bare Metal Update (BMU): In-band, and requires system reboot. Lenovo XClarity Essentials OneCLI: <ul style="list-style-type: none"> For OneCLI version earlier than 5.0.0: <ul style="list-style-type: none"> For drives supported by ThinkSystem V2 and V3 products (legacy drives): In-band, and does not require system reboot. For drives supported only by ThinkSystem V3 products (new drives): Staging to XCC and complete the update with XCC BMU (In-band, and requires system reboot.). For OneCLI 5.0.0 and later versions: In-band, and does not require system reboot. Bare Metal Update (BMU) only. | | | | | | | |

- **Lenovo XClarity Provisioning Manager**

From Lenovo XClarity Provisioning Manager, you can update the Lenovo XClarity Controller firmware, the UEFI firmware, and the Lenovo XClarity Provisioning Manager software.

Note: By default, the Lenovo XClarity Provisioning Manager Graphical User Interface is displayed when you start the server and press the key specified in the on-screen instructions. If you have changed that default to be the text-based system setup, you can bring up the Graphical User Interface from the text-based system setup interface.

For additional information about using Lenovo XClarity Provisioning Manager to update firmware, see:

“Firmware Update” section in the LXPM documentation compatible with your server at <https://pubs.lenovo.com/lxpm-overview/>

- **Lenovo XClarity Controller**

If you need to install a specific update, you can use the Lenovo XClarity Controller interface for a specific server.

Notes:

- To perform an in-band update through Windows or Linux, the operating system driver must be installed and the Ethernet-over-USB (sometimes called LAN over USB) interface must be enabled.

For additional information about configuring Ethernet over USB, see:

“Configuring Ethernet over USB” section in the XCC documentation version compatible with your server at <https://pubs.lenovo.com/lxcc-overview/>

- If you update firmware through the Lenovo XClarity Controller, make sure that you have downloaded and installed the latest device drivers for the operating system that is running on the server.

For additional information about using Lenovo XClarity Controller to update firmware, see:

“Updating Server Firmware” section in the XCC documentation compatible with your server at <https://pubs.lenovo.com/lxcc-overview/>

- **Lenovo XClarity Essentials OneCLI**

Lenovo XClarity Essentials OneCLI is a collection of command line applications that can be used to manage Lenovo servers. Its update application can be used to update firmware and device drivers for your servers. The update can be performed within the host operating system of the server (in-band) or remotely through the BMC of the server (out-of-band).

For additional information about using Lenovo XClarity Essentials OneCLI to update firmware, see:

https://pubs.lenovo.com/lxce-onecli/onecli_c_update

- **Lenovo XClarity Essentials UpdateXpress**

Lenovo XClarity Essentials UpdateXpress provides most of OneCLI update functions through a graphical user interface (GUI). It can be used to acquire and deploy Update Bundles (Service Packs) update packages and individual updates. Update Bundles (Service Packs) contain firmware and device driver updates for Microsoft Windows and for Linux.

You can obtain Lenovo XClarity Essentials UpdateXpress from the following location:

<https://datacentersupport.lenovo.com/solutions/Invo-xpress>

- **Lenovo XClarity Essentials Bootable Media Creator**

You can use Lenovo XClarity Essentials Bootable Media Creator to create bootable media that is suitable for firmware updates, VPD updates, inventory and FFDC collection, advanced system configuration, FoD Keys management, secure erase, RAID configuration, and diagnostics on supported servers.

You can obtain Lenovo XClarity Essentials BoMC from the following location:

<https://datacentersupport.lenovo.com/solutions/Invo-bomc>

- **Lenovo XClarity Administrator**

If you are managing multiple servers using the Lenovo XClarity Administrator, you can update firmware for all managed servers through that interface. Firmware management is simplified by assigning firmware-compliance policies to managed endpoints. When you create and assign a compliance policy to managed endpoints, Lenovo XClarity Administrator monitors changes to the inventory for those endpoints and flags any endpoints that are out of compliance.

For additional information about using Lenovo XClarity Administrator to update firmware, see:

https://pubs.lenovo.com/lxca/update_fw

- **Lenovo XClarity Integrator offerings**

Lenovo XClarity Integrator offerings can integrate management features of Lenovo XClarity Administrator and your server with software used in a certain deployment infrastructure, such as VMware vCenter, Microsoft Admin Center, or Microsoft System Center.

For additional information about using Lenovo XClarity Integrator to update firmware, see:

<https://pubs.lenovo.com/lxci-overview/>

Configure the firmware

Several options are available to install and set up the firmware for the server.

Important: Lenovo does not recommend setting option ROMs to **Legacy**, but you can conduct this setting if necessary. Note that this setting prevents UEFI drivers for the slot devices from loading, which may cause

negative side effects to Lenovo software, such as LXCA, OneCLI, and XCC. These side effects include but are not limited to the inability to determine adapter card details, such as model name and firmware levels. For example, "ThinkSystem RAID 930-16i 4GB Flash" may be displayed as "Adapter 06:00:00". In some cases, the functionality on a specific PCIe adapter may not be enabled properly.

- **Lenovo XClarity Provisioning Manager (LXPM)**

From Lenovo XClarity Provisioning Manager, you can configure the UEFI settings for your server.

Notes: The Lenovo XClarity Provisioning Manager provides a Graphical User Interface to configure a server. The text-based interface to system configuration (the Setup Utility) is also available. From Lenovo XClarity Provisioning Manager, you can choose to restart the server and access the text-based interface. In addition, you can choose to make the text-based interface the default interface that is displayed when you start LXPM. To do this, go to **Lenovo XClarity Provisioning Manager → UEFI Setup → System Settings → <F1>Start Control → Text Setup**. To start the server with Graphic User Interface, select **Auto** or **Tool Suite**.

See the following documentations for more information:

- Search for the LXPM documentation version compatible with your server at <https://pubs.lenovo.com/lxpm-overview/>
- *UEFI User Guide* at <https://pubs.lenovo.com/uefi-overview/>

- **Lenovo XClarity Essentials OneCLI**

You can use the config application and commands to view the current system configuration settings and make changes to Lenovo XClarity Controller and UEFI. The saved configuration information can be used to replicate or restore other systems.

For information about configuring the server using Lenovo XClarity Essentials OneCLI, see:

https://pubs.lenovo.com/lxce-onecli/onecli_c_settings_info_commands

- **Lenovo XClarity Administrator**

You can quickly provision and pre-provision all of your servers using a consistent configuration. Configuration settings (such as local storage, I/O adapters, boot settings, firmware, ports, and Lenovo XClarity Controller and UEFI settings) are saved as a server pattern that can be applied to one or more managed servers. When the server patterns are updated, the changes are automatically deployed to the applied servers.

Specific details about updating firmware using Lenovo XClarity Administrator are available at:

https://pubs.lenovo.com/lxca/server_configuring

- **Lenovo XClarity Controller**

You can configure the management processor for the server through the Lenovo XClarity Controller Web interface, the command-line interface, or Redfish API.

For information about configuring the server using Lenovo XClarity Controller, see:

“Configuring the Server” section in the XCC documentation compatible with your server at <https://pubs.lenovo.com/lxcc-overview/>

Memory module configuration

Memory performance depends on several variables, such as memory mode, memory speed, memory ranks, memory population and processor.

Information about optimizing memory performance and configuring memory is available at the Lenovo Press website:

<https://lenovopress.lenovo.com/servers/options/memory>

In addition, you can take advantage of a memory configurator, which is available at the following site:

https://dcsc.lenovo.com/#/memory_configuration

Enable Software Guard Extensions (SGX)

Intel® Software Guard Extensions (Intel® SGX) operates under the assumption that the security perimeter includes only the internals of the CPU package, and leaves the DRAM untrusted.

Complete the following steps to enable SGX.

- Step 1. **Make sure** to refer to “Memory module installation rules and order” section in the *User Guide* or *Hardware Maintenance Guide*, which specifies whether your server supports SGX and lists the memory module population sequence for SGX configuration. (DIMM configuration must be at least 8 DIMMs per socket to support SGX.)
- Step 2. Restart the system. Before the operating system starts up, press the key specified in the on-screen instructions to enter the Setup Utility. (For more information, see the “Startup” section in the LXPM documentation compatible with your server at <https://pubs.lenovo.com/lxpm-overview/>.)
- Step 3. Go to **System settings** → **Processors** → **UMA-Based Clustering** and disable the option.
- Step 4. Go to **System settings** → **Processors** → **Total Memory Encryption (TME)** and enable the option.
- Step 5. Save the changes, then go to **System settings** → **Processors** → **SW Guard Extension (SGX)** and enable the option.

RAID configuration

Using a Redundant Array of Independent Disks (RAID) to store data remains one of the most common and cost-efficient methods to increase server's storage performance, availability, and capacity.

RAID increases performance by allowing multiple drives to process I/O requests simultaneously. RAID can also prevent data loss in case of a drive failure by reconstructing (or rebuilding) the missing data from the failed drive using the data from the remaining drives.

RAID array (also known as RAID drive group) is a group of multiple physical drives that uses a certain common method to distribute data across the drives. A virtual drive (also known as virtual disk or logical drive) is a partition in the drive group that is made up of contiguous data segments on the drives. Virtual drive is presented up to the host operating system as a physical disk that can be partitioned to create OS logical drives or volumes.

An introduction to RAID is available at the following Lenovo Press website:

<https://lenovopress.lenovo.com/lp0578-lenovo-raid-introduction>

Detailed information about RAID management tools and resources is available at the following Lenovo Press website:

<https://lenovopress.lenovo.com/lp0579-lenovo-raid-management-tools-and-resources>

Intel VROC

Enabling Intel VROC

Before setting up RAID for NVMe drives, follow the below steps to enable VROC:

1. Restart the system. Before the operating system starts up, press the key specified in the on-screen instructions to enter the Setup Utility. (For more information, see the “Startup” section in the LXPM documentation compatible with your server at <https://pubs.lenovo.com/lxpm-overview/>.)
2. Go to **System settings → Devices and I/O Ports → Intel® VMD technology → Enable/Disable Intel® VMD** and enable the option.
3. Save the changes and reboot the system.

Intel VROC configurations

Intel offers various VROC configurations with different RAID level and SSD support. See the following for more details.

Notes:

- Supported RAID levels varies by model. For the RAID level supported by SR780a V3, see [Technical specifications](#).
- For more information about acquiring and installing the activation key, see <https://fod.lenovo.com/lkms>.

| Intel VROC configurations for PCIe NVMe SSDs | Requirements |
|--|--|
| Intel VROC Standard | <ul style="list-style-type: none">• Supports RAID levels 0, 1, and 10• Requires an activation key |
| Intel VROC Premium | <ul style="list-style-type: none">• Supports RAID levels 0, 1, 5, and 10• Requires an activation key |
| Bootable RAID | <ul style="list-style-type: none">• RAID 1 only• Supported by 5th Gen Intel® Xeon® Scalable processors (formerly codenamed as Emerald Rapids, EMR)• Requires an activation key |
| Intel VROC configurations for SATA SSDs | Requirements |
| Intel VROC SATA RAID | <ul style="list-style-type: none">• Supports RAID levels 0, 1, 5, and 10. |

Deploy the operating system

Several options are available to deploy an operating system on the server.

Available operating systems

- Canonical Ubuntu

Complete list of available operating systems: <https://lenovopress.lenovo.com/osig>.

Tool-based deployment

- **Multi-server**

Available tools:

- Lenovo XClarity Administrator

https://pubs.lenovo.com/lxca/compute_node_image_deployment

- Lenovo XClarity Essentials OneCLI

https://pubs.lenovo.com/lxce-onecli/onecli_r_uxspi_proxy_tool

- Lenovo XClarity Integrator deployment pack for SCCM (for Windows operating system only)

https://pubs.lenovo.com/lxci-deploypack-sccm/dpsccm_c_endtoend_deploy_scenario

- **Single-server**

Available tools:

- Lenovo XClarity Provisioning Manager

“OS Installation” section in the LXPM documentation compatible with your server at <https://pubs.lenovo.com/lxpm-overview/>

- Lenovo XClarity Essentials OneCLI

https://pubs.lenovo.com/lxce-onecli/onecli_r_uxspi_proxy_tool

- Lenovo XClarity Integrator deployment pack for SCCM (for Windows operating system only)

https://pubs.lenovo.com/lxci-deploypack-sccm/dpsccm_c_endtoend_deploy_scenario

Manual deployment

If you cannot access the above tools, follow the instructions below, download the corresponding *OS Installation Guide*, and deploy the operating system manually by referring to the guide.

1. Go to <https://datacentersupport.lenovo.com/solutions/server-os>.
2. Select an operating system from the navigation pane and click **Resources**.
3. Locate the “OS Install Guides” area and click the installation instructions. Then, follow the instructions to complete the operation system deployment task.

Back up the server configuration

After setting up the server or making changes to the configuration, it is a good practice to make a complete backup of the server configuration.

Make sure that you create backups for the following server components:

- **Management processor**

You can back up the management processor configuration through the Lenovo XClarity Controller interface. For details about backing up the management processor configuration, see:

“Backing up the BMC configuration” section in the XCC documentation compatible with your server at <https://pubs.lenovo.com/lxcc-overview/>.

Alternatively, you can use the `save` command from Lenovo XClarity Essentials OneCLI to create a backup of all configuration settings. For more information about the `save` command, see:

https://pubs.lenovo.com/lxce-onecli/onecli_r_save_command

- **Operating system**

Use your backup methods to back up the operating system and user data for the server.

Enable Intel® On Demand

A processor is equipped with various computing capabilities. Basic capabilities are available at the initial processor installation, while others remain inactivated. As development environment and tasks evolve,

computing demands may accelerate and require leverage of the previously inactivated processor capabilities. In such cases, user can select desired processor capabilities and activate them through Intel On Demand feature—a feature that allows user to customize processor capabilities according to environment and tasks at hand. The following section specifies system hardware and software requirement, Intel On Demand enabling and transferring procedures, and list of processor capabilities.

This documentation includes the following sections:

- “Supported processor” on page 67
- “Installation tool” on page 67
- Procedures for “Enabling Intel On Demand Features” on page 68
- Procedures for “Transferring Intel On Demand Features” on page 69
- XCC and LXCE OneCLI instructions for:
 - “Reading PPIN” on page 69
 - “Installing Intel On Demand to processor” on page 71
 - “Acquiring and uploading Intel On Demand State Report” on page 72
 - “Checking the Intel On Demand features installed in a processor” on page 74

Note: Depending on the model, the XCC Web GUI layout may be slightly different from the illustrations in this document.

Supported processor

Intel On Demand is only supported by Intel On Demand capable processors. For more information on Intel On Demand capable processors supported by SR780a V3, see <https://lenovopress.lenovo.com/>.

Note: All processors in a system must be installed with identical Intel On Demand feature.

Installation tool

Intel On Demand can be installed via Lenovo XClarity Controller (XCC) and Lenovo XClarity Essentials OneCLI (LXCE OneCLI). After confirming that your processor supports Intel On Demand, you also need to make sure the XCC and LXCE OneCLI installed in your system supports installing Intel On Demand.

1. Check if Lenovo XClarity Controller (XCC) supports installing Intel On Demand (two methods provided):

- **Via XCC WebGUI**

Go to **BMC Configuration → License**, if there is a section named **On Demand Capabilities for Intel CPU** in the page, it indicates that current XCC supports installing Intel On Demand, otherwise you need to update XCC firmware to the latest version to ensure it supports installing Intel On Demand.

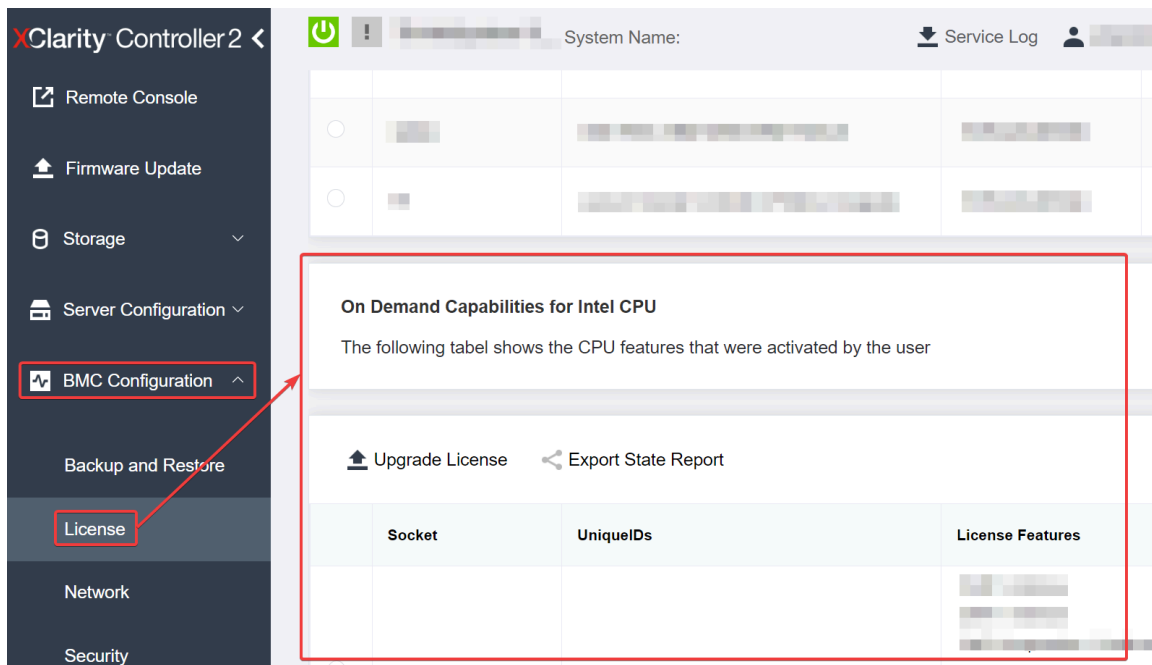

Figure 29. On Demand Capabilities for Intel CPU in XCC Web GUI

- **Via XCC REST API**

- Use the **GET** method with the following Request URL:
GET https://bmc_ip/redfish/v1/LicenseService/Licenses/
- In the response JSON object, the Members field includes the API such as /redfish/v1/LicenseService/Licenses/CPUX_OnDemandCapability, where X is the CPU numbering, it indicates that current XCC supports installing Intel On Demand, otherwise you need to update XCC firmware to the latest version to ensure it supports installing Intel On Demand.

For example:

```

"Members": [
  {
    "@odata.id": "/redfish/v1/LicenseService/Licenses/CPU1_OnDemandCapability"
  },
  {
    "@odata.id": "/redfish/v1/LicenseService/Licenses/CPU2_OnDemandCapability"
  },
]

```

- Check if LXCE OneCLI supports installing Intel On Demand

- LXCE OneCLI version must be at 4.2.0 or above.

Enabling Intel On Demand Features

- Select the Intel On Demand features that meets your workload needs, see [“Intel On Demand Features” on page 75](#).
- After completing ordering the features, you will receive Authorization Code via e-mail.
- PPIN is a mandatory information for enabling the features. Read the PPIN of the processor that is to be installed with the features. See [“Reading PPIN” on page 69](#).
- Go to <https://fod.lenovo.com/lkms> and input the Authorization Code to acquire the Activation Key.
- In the website, input Machine Type, Machine serial number, and PPIN.
- The website will generate the Activation Key. Download the Activation Key.

7. Install the features to the processor with the Activation Key via XCC or LXCE OneCLI. See [“Installing Intel On Demand to processor” on page 71](#).

Note: If more than one Activation Keys are acquired, it is mandatory to install them in the sequential order they were acquired. For example, start with installing the first acquired key, and proceed with the second acquired key, and so on.

8. AC cycle the server.
9. (Optional) Upload Intel On Demand State Report. See [“Acquiring and uploading Intel On Demand State Report” on page 72](#).

The State Report represents the current configuration state of the Intel On Demand capable processors. Lenovo accepts State Reports from customers to calibrate the current state of the Intel On Demand capable processors.

10. To see the features installed in a processor, see [“Checking the Intel On Demand features installed in a processor” on page 74](#).

For reference, see https://pubs.lenovo.com/lenovo_fod.

Transferring Intel On Demand Features

After replacing a processor, you may need to transfer the features from the defective processor to the new processor. Complete the following steps to transfer features to new processor.

1. Before removing the defective processor from the system, read the PPIN of the defective processor. See [“Reading PPIN” on page 69](#).
2. After installing the new processor, read the PPIN of the new processor. See [“Reading PPIN” on page 69](#).
3. Go to <https://fod.lenovo.com/lkms> and input the PPIN of the defective processor. (Input PPIN in the UID section.)
4. Select the features to be transferred.
5. Input the PPIN of the new processor.
6. The website will generate the new Activation Key. Download the new Activation Key. See [“Installing Intel On Demand to processor” on page 71](#).
7. Install the features to the new processor with the new Activation Key via XCC or LXCE OneCLI.
8. AC cycle the server.
9. (Optional) Upload Intel On Demand State Report. See [“Acquiring and uploading Intel On Demand State Report” on page 72](#).

The State Report represents the current configuration state of the Intel On Demand capable processors. Lenovo accepts State Reports from customers to calibrate the current state of the Intel On Demand capable processors.

10. To see the features installed in a processor, see [“Checking the Intel On Demand features installed in a processor” on page 74](#).

For reference, see https://pubs.lenovo.com/lenovo_fod.

Reading PPIN

Protected Processor Inventory Number, or PPIN, is a mandatory information for enabling Intel On Demand. PPIN can be read via XCC Web GUI, XCC REST API, and LXCE OneCLI. See the following for more information.

Reading PPIN via XCC Web GUI

Open XCC Web GUI, go to **Inventory page** → **CPU tab** → **Expand** → **PPIN**

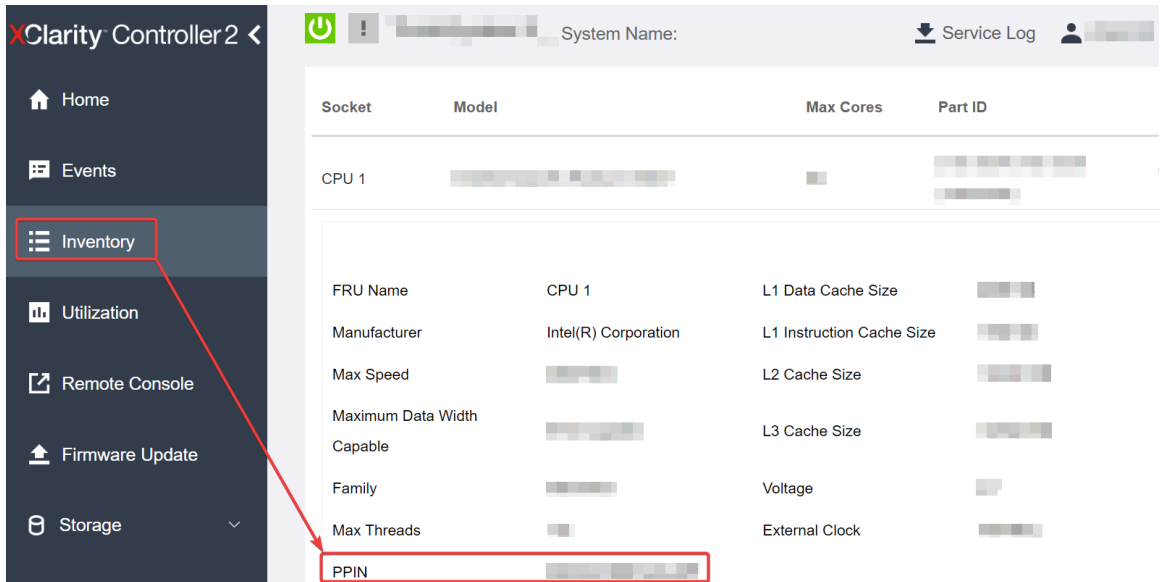

Figure 30. Reading PPIN via XCC Web GUI

Reading PPIN via XCC REST API

1. Use the **GET** method with the following Request URL:
 GET https://bmc_ip/redfish/v1/Systems/1/Processors
 For example:
 GET https://bmc_ip/redfish/v1/Systems/1/Processors
2. In the response JSON object, the Members field shows reference link to an element of processor resource.

For example:

```
"Members":[
{
@odata.id: "/redfish/v1/Systems/1/Processors/1"
},
{
@odata.id: "/redfish/v1/Systems/1/Processors/2"
}
],
```

3. Select the processor you need to read the PPIN from. Use the **GET** method with the following Request URL, where x is the CPU numbering:
 GET https://bmc_ip/redfish/v1/Systems/1/Processors/x
 For example, to read Processor 1 PPIN, see the following:
 GET https://bmc_ip/redfish/v1/Systems/1/Processors/1
4. In the response JSON object, the ProcessorId field shows the ProtectedIdentificationNumber field, which is the PPIN info of the requested CPU.

For example:

```
"ProcessorId":{
  "ProtectedIdentificationNumber":"1234567890xxxyyy"
},
```

Reading PPIN via LXCE OneCLI

Input the following command:

```
OneCli.exe fod showppin -b XCC_USER:XCC_PASSWORD@XCC_HOST
```

The output shows PPIN information. For example:

Machine Type: 7D75

Serial Number: 7D75012345

FoD PPIN result:

```
=====
| Socket ID |          PPIN          |
| Processor 1 | 1234567890xxxyyy |
| Processor 2 | 9876543210zzzyyy |
=====
```

Installing Intel On Demand to processor

Install Intel On Demand features to the processor with the Activation Key downloaded from the <https://fod.lenovo.com/lkms> via XCC Web GUI, XCC REST API or LXCE OneCLI.

Use XCC Web GUI to install Intel On Demand

1. Open XCC Web GUI, go to **BMC Configuration → License → On Demand Capabilities for Intel CPU → Upgrade License → Browse → Import** to upload the Activation Key

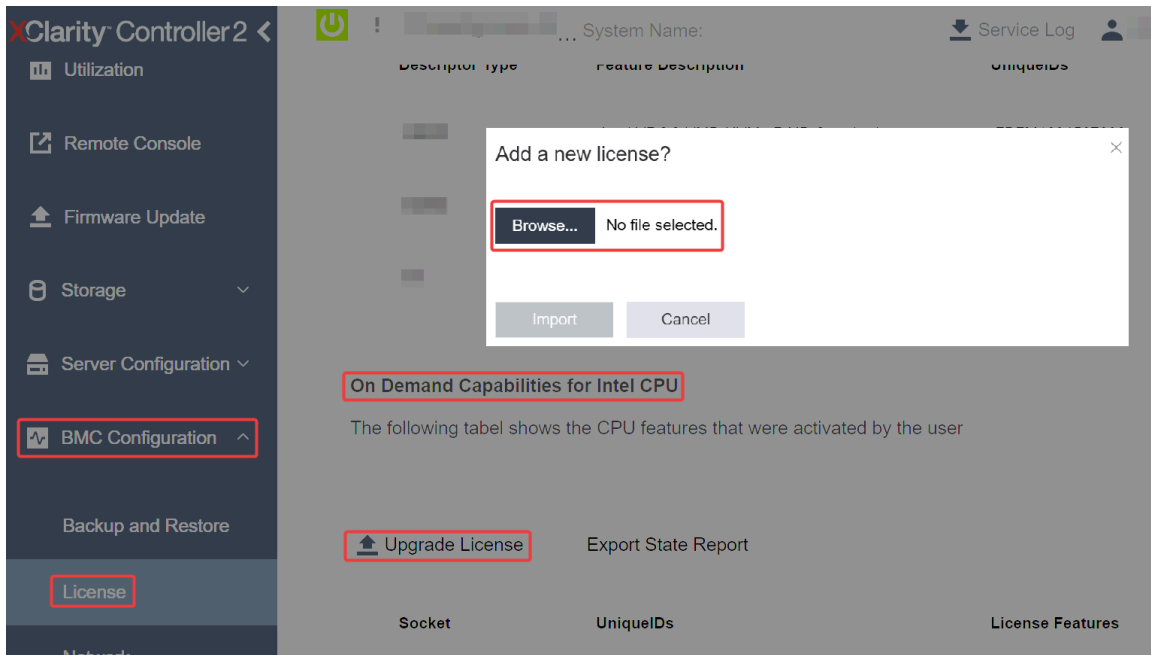

Figure 31. Uploading Activation Key via XCC Web GUI

2. If the installation is successful, the Web GUI will show a pop-up window with the message “License key upgraded successfully. The features will be activated on the processor after system power cycle”.

Otherwise, see “Enable Intel® On Demand Troubleshooting” on page 76.

Use XCC REST API to install Intel On Demand

1. Use the **POST** method with the following Request URL:
POST https://bmc_ip/redfish/v1/LicenseService/Licenses
2. Transfer Activation Key to base64 string at first and fill it into the LicenseString field as POST data.
{
 "LicenseString": ""
}
3. If the installation is successful, XCC REST API show the message “License key upgraded successfully. The features will be activated on the processor after system power cycle”.

Otherwise, see “Enable Intel® On Demand Troubleshooting” on page 76.

Use LXCE OneCLI to install Intel On Demand

Input the following command, where <key_file> specifies the Activation Key:
OneCli.exe fod install --keyfile <key_file>

If successfully installed, the response will show:
Successfully install key

Call Lenovo support if the response shows the following:
Failed to install key

Acquiring and uploading Intel On Demand State Report

After completing enabling or transferring Intel On Demand, acquire and upload the State Report via XCC Web GUI, XCC REST API, and LXCE OneCLI. See the following for more information.

Use XCC Web GUI to upload State Report

1. Open XCC Web GUI, go to **BMC Configuration** → **License** → **On Demand Capabilities for Intel CPU** → **Choose CPU** → **Export State Report**

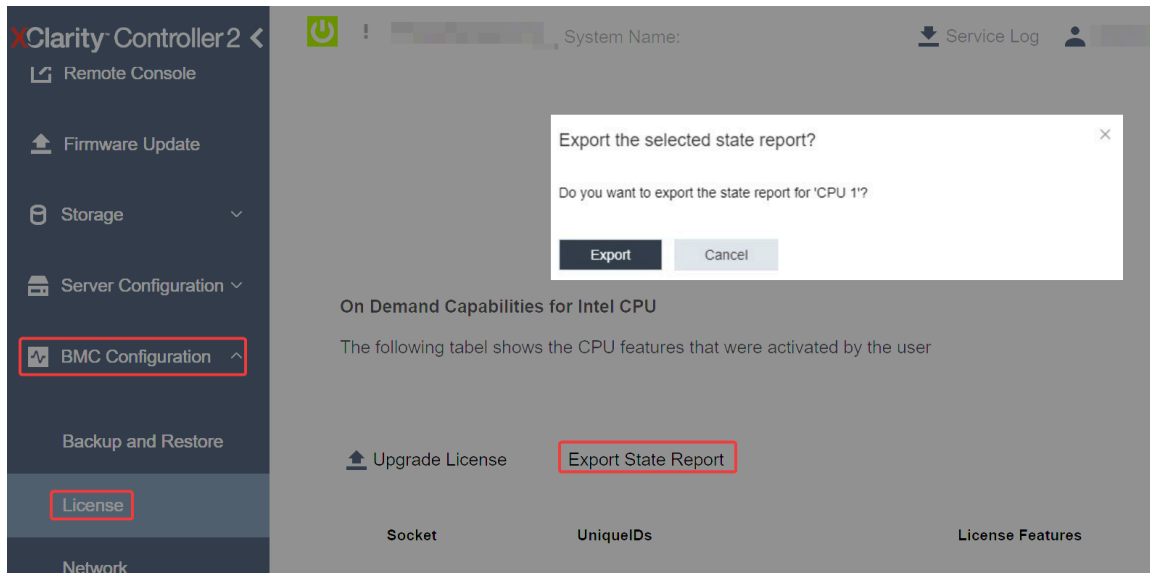

Figure 32. Export State Report via XCC Web GUI

2. Upload State Report via “On Demand Feedback” section in <https://fod.lenovo.com/lkms>.

Use XCC REST API to upload State Report

1. Use the **GET** method with the following Request URL to retrieve CPU State Report API, where X is the CPU numbering:
GET https://bmc_ip/redfish/v1/LicenseService/Licenses/CPUX_OnDemandCapability
For example, to retrieve CPU 1 State Report API, see the following:
GET https://bmc_ip/redfish/v1/LicenseService/Licenses/CPU1_OnDemandCapability
2. In the response JSON object, the response of the target field of the `LenovoLicense.ExportStateReport` field is the CPU State Report API, where X is the CPU numbering:

```
"Actions": {  
  "Oem": {  
    "#LenovoLicense.ExportStateReport": {
```



```

        "title": "ExportStateReport",
        "target": "/redfish/v1/LicenseService/Licenses/CPUX_OnDemandCapability/Actions/Oem/LenovoLicense.ExportStateReport"
    }
},

```

In the following example, the response of the target field is the CPU 1 State Report API. Copy the CPU 1 State Report API.

```

"Actions": {
  "Oem": {
    "#LenovoLicense.ExportStateReport": {
      "title": "ExportStateReport",
      "target": "/redfish/v1/LicenseService/Licenses/CPU1_OnDemandCapability/Actions/Oem/LenovoLicense.ExportStateReport"
    }
  }
},

```

3. Retrieve the State Report.

- Use the **POST** method with the following Request URL with CPU State Report API to retrieve the State Report, where X is the CPU numbering:

POST https://bmc_ip/redfish/v1/LicenseService/Licenses/CPUX_OnDemandCapability/Actions/Oem/LenovoLicense.ExportStateReport

For example, to retrieve CPU 1 State Report, see the following:

POST https://bmc_ip/redfish/v1/LicenseService/Licenses/CPU1_OnDemandCapability/Actions/Oem/LenovoLicense.ExportStateReport

- Use an empty JSON object as POST data. When using API tool such as Postman, fill an empty JSON object in **Body** → **Raw** → **JSON**, fill a NULL object '{}'

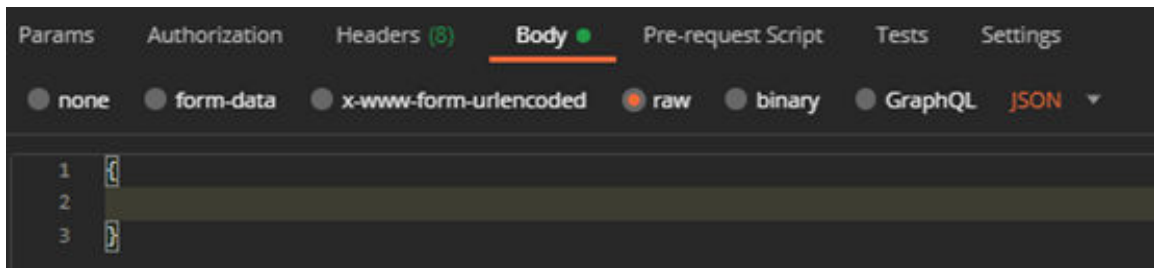

- In the response, retrieve the State Report in the stateReports field.

```

{
  "stateReports": [
    {
      "syntaxVersion": "1.0",
      "timestamp": "",
      "objectId": "",
      "hardwareComponentData": [
        {
          "hardwareId": {
            "type": "PPIN",
            "value": ""
          },
          "stateCertificate": {
            "pendingCapabilityActivationPayloadCount": ,
            "value": ""
          },
          "hardwareType": "CPU"
        }
      ]
    }
  ]
}

```

5. Upload State Report via “On Demand Feedback” section in <https://fod.lenovo.com/lkms>.

Use LXCE OneCLI to upload State Report

1. Acquire State Report with the following command:
`OneCli.exe fod exportreport -b XCC_USER:XCC_PASSWORD@XCC_HOST`
2. Upload State Report with the following command:
`OneCli.exe fod uploadreport --file CPU1_xxxxxx_StateReport.json --kmsid KMS_USER:KMS_PASSWORD`

Where:

CPU1_xxxxxx_StateReport.json is the file name downloaded from the **fod exportreport** command in Step 1.

KMS_USER and KMS_PASSWORD are your ID and password on the <https://fod.lenovo.com/lkms>.

Checking the Intel On Demand features installed in a processor

You can check the Intel On Demand features installed in a processor via XCC Web GUI, XCC REST API, and LXCE OneCLI. See the following for more information.

Note: If the processor has not been installed with any license, it would not appear in the **On Demand Capabilities for Intel CPU** section in XCC Web GUI.

Use XCC Web GUI to check the Intel On Demand features installed in a processor

Go to **BMC Configuration** → **License** → **On Demand Capabilities for Intel CPU** → **Choose CPU** → **License Features**, where the installed features are listed.

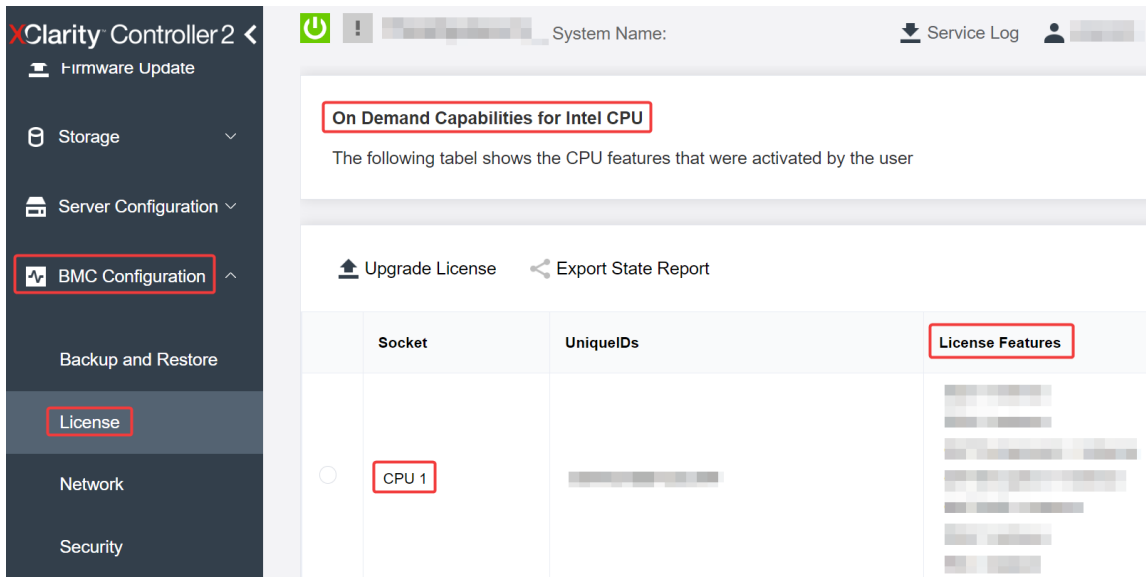

Figure 33. Checking the Intel On Demand features installed in a processor in XCC Web GUI

Use XCC REST API to check the Intel On Demand features installed in a processor

1. Use the **GET** method with the following Request URL to retrieve Intel On Demand features installed on CPU X, where X is the CPU numbering:
`GET https://bmc_ip/redfish/v1/LicenseService/Licenses/CPUX_OnDemandCapability`
 For example, to retrieve Intel On Demand features installed on CPU 1, see the following:
`GET https://bmc_ip/redfish/v1/LicenseService/Licenses/CPU1_OnDemandCapability`
2. In the response JSON object, the **FeatureList** field contains the Intel On Demand features installed in this processor.

```

    "Dem": {
      "Lenovo":{
        "FeatureList":[]
        "@odata.type":""
      }
    },

```

Use LXCE OneCLI to check the Intel On Demand features installed in a processor

1. Check installed features with the following command:
`OneCli.exe fod report -b XCC_USER:XCC_PASSWORD@XCC_HOST`
2. The output shows all license, including Intel On Demand features. For example:

```

FoD Reports result:
=====
| Feature | Key | Status | Description | User | Expired |
| Type | ID | | Feature List | Reminding | Date |
=====
| N/A | CPU1_OnDemandCapability | StandbyOffline | DSA 4 instances, | N/A | N/A |
| | | | IAA 4 instances | | |
=====
| N/A | CPU2_OnDemandCapability | Enabled | DSA 4 instances, | N/A | N/A |
| | | | IAA 4 instances | | |
=====
| 004a | XCC2_Platinum | Enabled | Lenovo XClarity Controller 2 | N/A | N/A |
| | | | Platinum Upgrade | | |
=====
Succeed.

```

Intel On Demand Features

Intel On Demand features are listed below. Supported features vary by product, for more information, see <https://lenovopress.lenovo.com/>.

Features

- **Intel Quick Assist Technology (Intel QAT)¹**

Intel® QAT which helps free up processor cores by offloading encryption, decryption, and compression so systems can serve a larger number of clients or use less power. With Intel QAT, 4th gen Intel Xeon Scalable processors are the highest performance CPUs that can compress and encrypt in a single data flow.

- **Intel Dynamic Load Balancer (Intel DLB)²**

Intel DLB is a hardware managed system of queues and arbiters connecting producers and consumers. It is a PCI device envisaged to live in the server CPU uncore and can interact with software running on cores, and potentially with other devices.

- **Intel Data Streaming Accelerator (Intel DSA)¹**

Intel DSA drives high performance for storage, networking, and data-intensive workloads by improving streaming data movement and transformation operations. Designed to offload the most common data movement tasks that cause overhead in data center-scale deployments, Intel DSA helps speed up data movement across the CPU, memory, caches, all attached memory, storage, and network devices.

- **Intel In Memory Accelerator (Intel IAA)¹**

Intel IAA helps run database and analytics workloads faster, with potentially greater power efficiency. This built-in accelerator increases query throughput and decreases the memory footprint for in-memory database and big data analytics workloads. Intel IAA is ideal for in-memory databases, and source databases.

- **Intel Software Guard Extensions (Intel SGX) 512 GB³**

Intel® SGX offers hardware-based memory encryption that isolates specific application code and data in memory. Intel SGX allows user-level code to allocate private regions of memory, called enclaves, which are designed to be protected from processes running at higher privilege levels.

References

- ¹*Achieve Performance Advantage with Intel oneAPI, AI Tools, and 4th Gen Intel® Xeon® Scalable Processors Featuring Built-in Accelerator Engines*, (n.d.). Intel. <https://www.intel.com/content/www/us/en/developer/articles/technical/performance-advantage-with-xeon-and-oneapi-tools.html>
- ²*Intel® Dynamic Load Balancer*, (2023, May 23) Intel. <https://www.intel.com/content/www/us/en/download/686372/intel-dynamic-load-balancer.html>
- ³*Intel® Software Guard Extensions (Intel® SGX)*, (n.d.) Intel. <https://www.intel.com/content/www/us/en/architecture-and-technology/software-guard-extensions.html>

Enable Intel® On Demand Troubleshooting

Refer to the table below for Intel On Demand installation error messages and user actions.

Table 29. Intel On Demand installation messages and user actions

| Message | User Action |
|--|--|
| License key upgraded successfully. The features will be activated on the processor after system power cycle. | You can activate Intel On Demand after performing one system power cycle. |
| The activation key format is invalid | Check if you have uploaded the correct Activation Key file. If the error persists, contact Lenovo support. |
| Invalid processor PPIN in Activation key | Contact Lenovo support. |
| The license was installed in the processor already | You have already installed this activation key. Check if the activation key you uploaded is correct. |
| Not enough NMRAM space in the processor | Contact Lenovo support. |
| Internal error | Contact Lenovo support. |
| Cold reset needed before next provisioning | If you want to continue installing an activation key, perform a system power cycle at first. |
| Unable to provision LAC due to FEH error | Contact Lenovo support. |
| Unable to import license in shutdown state, please try again after power on. | Power on the system before installing Intel On Demand. |
| Unable to import license due to On Demand Capabilities information is in progress. Please try again later. | If you want to continue installing an activation key, try again later. |

Appendix A. Getting help and technical assistance

If you need help, service, or technical assistance or just want more information about Lenovo products, you will find a wide variety of sources available from Lenovo to assist you.

On the World Wide Web, up-to-date information about Lenovo systems, optional devices, services, and support are available at:

<http://datacentersupport.lenovo.com>

Note: IBM is Lenovo's preferred service provider for ThinkSystem.

Before you call

Before you call, there are several steps that you can take to try and solve the problem yourself. If you decide that you do need to call for assistance, gather the information that will be needed by the service technician to more quickly resolve your problem.

Attempt to resolve the problem yourself

You can solve many problems without outside assistance by following the troubleshooting procedures that Lenovo provides in the online help or in the Lenovo product documentation. The online help also describes the diagnostic tests that you can perform. The documentation for most systems, operating systems, and programs contains troubleshooting procedures and explanations of error messages and error codes. If you suspect a software problem, see the documentation for the operating system or program.

You can find the product documentation for your ThinkSystem products at the following location:

<https://pubs.lenovo.com/>

You can take these steps to try to solve the problem yourself:

- Check all cables to make sure that they are connected.
- Check the power switches to make sure that the system and any optional devices are turned on.
- Check for updated software, firmware, and operating-system device drivers for your Lenovo product. (See the following links) The Lenovo Warranty terms and conditions state that you, the owner of the Lenovo product, are responsible for maintaining and updating all software and firmware for the product (unless it is covered by an additional maintenance contract). Your service technician will request that you upgrade your software and firmware if the problem has a documented solution within a software upgrade.
 - Drivers and software downloads
 - <https://datacentersupport.lenovo.com/tw/en/products/servers/thinksystem/sr780av3/7dj5/downloads/driver-list/>
 - Operating system support center
 - <https://datacentersupport.lenovo.com/solutions/server-os>
 - Operating system installing instructions
 - <https://pubs.lenovo.com/thinksystem#os-installation>
- If you have installed new hardware or software in your environment, check <https://serverproven.lenovo.com> to make sure that the hardware and software are supported by your product.
- Refer to “Problem Determination” in *User Guide* or *Hardware Maintenance Guide* for instructions on isolating and solving issues.

- Go to <http://datacentersupport.lenovo.com> and check for information to help you solve the problem.

To find the Tech Tips available for your server:

1. Go to <http://datacentersupport.lenovo.com> and navigate to the support page for your server.
2. Click on **How To's** from the navigation pane.
3. Click **Article Type** → **Solution** from the drop-down menu.

Follow the on-screen instructions to choose the category for the problem that you are having.

- Check Lenovo Data Center Forum at https://forums.lenovo.com/t5/Datacenter-Systems/ct-p/sv_eg to see if someone else has encountered a similar problem.

Gathering information needed to call Support

If you require warranty service for your Lenovo product, the service technicians will be able to assist you more efficiently if you prepare the appropriate information before you call. You can also go to <http://datacentersupport.lenovo.com/warrantylookup> for more information about your product warranty.

Gather the following information to provide to the service technician. This data will help the service technician quickly provide a solution to your problem and ensure that you receive the level of service for which you might have contracted.

- Hardware and Software Maintenance agreement contract numbers, if applicable
- Machine type number (Lenovo 4-digit machine identifier). Machine type number can be found on the ID label, see “[Identify the server and access the Lenovo XClarity Controller](#)” on page 53.
- Model number
- Serial number
- Current system UEFI and firmware levels
- Other pertinent information such as error messages and logs

As an alternative to calling Lenovo Support, you can go to <https://support.lenovo.com/servicerequest> to submit an Electronic Service Request. Submitting an Electronic Service Request will start the process of determining a solution to your problem by making the pertinent information available to the service technicians. The Lenovo service technicians can start working on your solution as soon as you have completed and submitted an Electronic Service Request.

Collecting service data

To clearly identify the root cause of a server issue or at the request of Lenovo Support, you might need collect service data that can be used for further analysis. Service data includes information such as event logs and hardware inventory.

Service data can be collected through the following tools:

- **Lenovo XClarity Provisioning Manager**

Use the Collect Service Data function of Lenovo XClarity Provisioning Manager to collect system service data. You can collect existing system log data or run a new diagnostic to collect new data.

- **Lenovo XClarity Controller**

You can use the Lenovo XClarity Controller web interface or the CLI to collect service data for the server. The file can be saved and sent to Lenovo Support.

- For more information about using the web interface to collect service data, see the “Backing up the BMC configuration” section in the XCC documentation compatible with your server at <https://pubs.lenovo.com/lxcc-overview/>.

- For more information about using the CLI to collect service data, see the “XCC `ffdc` command” section in the XCC documentation compatible with your server at <https://pubs.lenovo.com/lxcc-overview/>.

- **Lenovo XClarity Administrator**

Lenovo XClarity Administrator can be set up to collect and send diagnostic files automatically to Lenovo Support when certain serviceable events occur in Lenovo XClarity Administrator and the managed endpoints. You can choose to send diagnostic files to Lenovo Support using Call Home or to another service provider using SFTP. You can also manually collect diagnostic files, open a problem record, and send diagnostic files to the Lenovo Support.

You can find more information about setting up automatic problem notification within the Lenovo XClarity Administrator at https://pubs.lenovo.com/lxca/admin_setupcallhome.

- **Lenovo XClarity Essentials OneCLI**

Lenovo XClarity Essentials OneCLI has inventory application to collect service data. It can run both in-band and out-of-band. When running in-band within the host operating system on the server, OneCLI can collect information about the operating system, such as the operating system event log, in addition to the hardware service data.

To obtain service data, you can run the `getinfor` command. For more information about running the `getinfor`, see https://pubs.lenovo.com/lxce-onecli/onecli_r_getinfor_command.

Contacting Support

You can contact Support to obtain help for your issue.

You can receive hardware service through a Lenovo Authorized Service Provider. To locate a service provider authorized by Lenovo to provide warranty service, go to <https://datacentersupport.lenovo.com/serviceprovider> and use filter searching for different countries. For Lenovo support telephone numbers, see <https://datacentersupport.lenovo.com/supportphonenumber> for your region support details.

Appendix B. Documents and supports

This section provides handy documents, driver and firmware downloads, and support resources.

Documents download

This section provides introduction and download link for handy documents.

Documents

Download the following product documentations at:

https://pubs.lenovo.com/sr780a-v3/pdf_files.html

- **Rail Installation Guides**
 - Rail installation in a rack
- **GPU Water Loop Service Guide**
 - GPU water loop maintenance and service
- **User Guide**
 - Complete overview, system configuration, hardware components replacing, and troubleshooting.
Selected chapters from *User Guide*:
 - **System Configuration Guide** : Server overview, components identification, system LEDs and diagnostics display, product unboxing, setting up and configuring the server.
 - **Hardware Maintenance Guide** : Installing hardware components, cable routing, and troubleshooting.
- **Messages and Codes Reference**
 - XClarity Controller, LXPM, and uEFI events
- **UEFI Manual**
 - UEFI setting introduction

Support websites

This section provides driver and firmware downloads and support resources.

Support and downloads

- Drivers and Software download website for ThinkSystem SR780a V3
 - <https://datacentersupport.lenovo.com/tw/en/products/servers/thinksystem/sr780av3/7dj5/downloads/driver-list/>
- Lenovo Data Center Forum
 - https://forums.lenovo.com/t5/Datacenter-Systems/ct-p/sv_eg
- Lenovo Data Center Support for ThinkSystem SR780a V3
 - <https://datacentersupport.lenovo.com/products/servers/thinksystem/sr780av3/7dj5>
- Lenovo License Information Documents
 - <https://datacentersupport.lenovo.com/documents/Invo-eula>

- Lenovo Press website (Product Guides/Datasheets/White papers)
 - <https://lenovopress.lenovo.com/>
- Lenovo Privacy Statement
 - <https://www.lenovo.com/privacy>
- Lenovo Product Security Advisories
 - https://datacentersupport.lenovo.com/product_security/home
- Lenovo Product Warranty Plans
 - <http://datacentersupport.lenovo.com/warrantylookup>
- Lenovo Server Operating Systems Support Center website
 - <https://datacentersupport.lenovo.com/solutions/server-os>
- Lenovo ServerProven website (Options compatibility lookup)
 - <https://serverproven.lenovo.com>
- Operating System Installation Instructions
 - <https://pubs.lenovo.com/thinksystem#os-installation>
- Submit an eTicket (service request)
 - <https://support.lenovo.com/servicerequest>
- Subscribe to Lenovo Data Center Group product notifications (Stay up to date on firmware updates)
 - <https://datacentersupport.lenovo.com/solutions/ht509500>

Appendix C. Notices

Lenovo may not offer the products, services, or features discussed in this document in all countries. Consult your local Lenovo representative for information on the products and services currently available in your area.

Any reference to a Lenovo product, program, or service is not intended to state or imply that only that Lenovo product, program, or service may be used. Any functionally equivalent product, program, or service that does not infringe any Lenovo intellectual property right may be used instead. However, it is the user's responsibility to evaluate and verify the operation of any other product, program, or service.

Lenovo may have patents or pending patent applications covering subject matter described in this document. The furnishing of this document is not an offer and does not provide a license under any patents or patent applications. You can send inquiries in writing to the following:

*Lenovo (United States), Inc.
8001 Development Drive
Morrisville, NC 27560
U.S.A.
Attention: Lenovo Director of Licensing*

LENOVO PROVIDES THIS PUBLICATION "AS IS" WITHOUT WARRANTY OF ANY KIND, EITHER EXPRESS OR IMPLIED, INCLUDING, BUT NOT LIMITED TO, THE IMPLIED WARRANTIES OF NON-INFRINGEMENT, MERCHANTABILITY OR FITNESS FOR A PARTICULAR PURPOSE. Some jurisdictions do not allow disclaimer of express or implied warranties in certain transactions, therefore, this statement may not apply to you.

This information could include technical inaccuracies or typographical errors. Changes are periodically made to the information herein; these changes will be incorporated in new editions of the publication. Lenovo may make improvements and/or changes in the product(s) and/or the program(s) described in this publication at any time without notice.

The products described in this document are not intended for use in implantation or other life support applications where malfunction may result in injury or death to persons. The information contained in this document does not affect or change Lenovo product specifications or warranties. Nothing in this document shall operate as an express or implied license or indemnity under the intellectual property rights of Lenovo or third parties. All information contained in this document was obtained in specific environments and is presented as an illustration. The result obtained in other operating environments may vary.

Lenovo may use or distribute any of the information you supply in any way it believes appropriate without incurring any obligation to you.

Any references in this publication to non-Lenovo Web sites are provided for convenience only and do not in any manner serve as an endorsement of those Web sites. The materials at those Web sites are not part of the materials for this Lenovo product, and use of those Web sites is at your own risk.

Any performance data contained herein was determined in a controlled environment. Therefore, the result obtained in other operating environments may vary significantly. Some measurements may have been made on development-level systems and there is no guarantee that these measurements will be the same on generally available systems. Furthermore, some measurements may have been estimated through extrapolation. Actual results may vary. Users of this document should verify the applicable data for their specific environment.

Trademarks

LENOVO and THINKSYSTEM are trademarks of Lenovo.

All other trademarks are the property of their respective owners.

Important notes

Processor speed indicates the internal clock speed of the processor; other factors also affect application performance.

CD or DVD drive speed is the variable read rate. Actual speeds vary and are often less than the possible maximum.

When referring to processor storage, real and virtual storage, or channel volume, KB stands for 1 024 bytes, MB stands for 1 048 576 bytes, and GB stands for 1 073 741 824 bytes.

When referring to hard disk drive capacity or communications volume, MB stands for 1 000 000 bytes, and GB stands for 1 000 000 000 bytes. Total user-accessible capacity can vary depending on operating environments.

Maximum internal hard disk drive capacities assume the replacement of any standard hard disk drives and population of all hard-disk-drive bays with the largest currently supported drives that are available from Lenovo.

Maximum memory might require replacement of the standard memory with an optional memory module.

Each solid-state memory cell has an intrinsic, finite number of write cycles that the cell can incur. Therefore, a solid-state device has a maximum number of write cycles that it can be subjected to, expressed as total bytes written (TBW). A device that has exceeded this limit might fail to respond to system-generated commands or might be incapable of being written to. Lenovo is not responsible for replacement of a device that has exceeded its maximum guaranteed number of program/erase cycles, as documented in the Official Published Specifications for the device.

Lenovo makes no representations or warranties with respect to non-Lenovo products. Support (if any) for the non-Lenovo products is provided by the third party, not Lenovo.

Some software might differ from its retail version (if available) and might not include user manuals or all program functionality.

Electronic emission notices

When you attach a monitor to the equipment, you must use the designated monitor cable and any interference suppression devices that are supplied with the monitor.

Additional electronic emissions notices are available at:

https://pubs.lenovo.com/important_notices/

Taiwan Region BSMI RoHS declaration

| 單元 Unit | 限用物質及其化學符號 Restricted substances and its chemical symbols | | | | | |
|---------|--|------------------|------------------|--|--|--|
| | 鉛Lead (PB) | 汞Mercury (Hg) | 鎘Cadmium (Cd) | 六價鉻 Hexavalent chromium (Cr ⁺⁶) | 多溴聯苯 Polybrominated biphenyls (PBB) | 多溴二苯醚 Polybrominated diphenyl ethers (PBDE) |
| 機架 | ○ | ○ | ○ | ○ | ○ | ○ |
| 外部蓋板 | ○ | ○ | ○ | ○ | ○ | ○ |
| 機械組零件 | - | ○ | ○ | ○ | ○ | ○ |
| 空氣傳動設備 | - | ○ | ○ | ○ | ○ | ○ |
| 冷卻組零件 | - | ○ | ○ | ○ | ○ | ○ |
| 內存模組 | - | ○ | ○ | ○ | ○ | ○ |
| 處理器模組 | - | ○ | ○ | ○ | ○ | ○ |
| 圖形處理器模組 | - | ○ | ○ | ○ | ○ | ○ |
| 電纜組零件 | - | ○ | ○ | ○ | ○ | ○ |
| 電源供應器 | - | ○ | ○ | ○ | ○ | ○ |
| 儲備設備 | - | ○ | ○ | ○ | ○ | ○ |
| 印刷電路板 | - | ○ | ○ | ○ | ○ | ○ |

備考1. “超出0.1 wt %” 及 “超出0.01 wt %” 係指限用物質之百分比含量超出百分比含量基準值。
 Note1 : “exceeding 0.1wt%” and “exceeding 0.01 wt%” indicate that the percentage content of the restricted substance exceeds the reference percentage value of presence condition.

備考2. “○” 係指該項限用物質之百分比含量未超出百分比含量基準值。
 Note2 : “○” indicates that the percentage content of the restricted substance does not exceed the percentage of reference value of presence.

備考3. “-” 係指該項限用物質為排除項目。
 Note3 : The “-” indicates that the restricted substance corresponds to the exemption.

0724

Taiwan Region import and export contact information

Contacts are available for Taiwan Region import and export information.

委製商/進口商名稱: 台灣聯想環球科技股份有限公司
進口商地址: 台北市南港區三重路 66 號 8 樓
進口商電話: 0800-000-702

Lenovo