Rack Installation Instructions

Read these guidelines first

Review the documentation that comes with the rack for safety and cabling information. Before you install the server in a rack, read the following guidelines:

- Two or more people are required to install 2U/4U or larger devices in a rack.
- Some illustrations might differ from your server. All types of server are removed and installed in a similar manner.
- See the *Maintenance Manual* for the maximum room air temperature.
- Install the server only in a rack that has perforated doors.
- Do not block any air vents, usually 15 cm (6 inches) of air space provides proper airflow.
- Plan the device installation starting from the bottom of the rack.
- Install the heaviest device in the bottom of the rack.
- Do not leave open space above or below an installed server in your rack. To help prevent damage to server components, always install a filler panel to cover the open space and to help ensure proper air circulation.
- Do not extend more than one device out of the rack at the same time.
- Connect all power cords to properly wired and grounded electrical outlets.
- Do not overload the power outlet when installing multiple devices in the rack.
- Remove the rack doors and side panels to provide easier access during installation.
- Install the server in a rack that meets the following requirements:
 - Minimum depth of 70 mm (2.76 inches) between the front mounting flange and inside of the front door.
 - Minimum depth of 190 mm (7.48 inches) between the rear mounting flange and inside of the rear door.
 - The maximum distance between the front and the rear EIA flange of the rack is 810 mm (31.9 inches).
 - If you want to install the rails and a 0U PDU into the same rack, the rack must meet the following height and depth requirements:
 - 42U or higher
 - ThinkSystem Toolless Friction Rail: at least 1000-mm (39.37-inch) deep

Table 1. Safety notice



CAUTION:
Use safe practices when lifting



≥ 18.0 kg (39.7 lb)
< 32.0 kg (70.5 lb)



≥ 32.0 kg (70.5 lb)
< 55.0 kg (121.2 lb)



≥ 55.0 kg (121.2 lb)
< 100.0 kg (220.5 lb)



CAUTION:
Do not place any objects on the top of the rack-mounted devices



Package items

Information below shows the items that you need to install the server in a rack. If any items are missing or damaged, contact your place of purchase.

ThinkSystem Toolless Friction Rail:

- One left rail and one right rail
- Two M5 screws

Table 2. The length of the rail

Rail	ThinkSystem Toolless Friction Rail
Rail length	728.1 mm (28.6 inches)

ThinkSystem Toolless Friction Rail

To install a server into a rack using the ThinkSystem Toolless Friction Rail, complete the following steps:

- 1.** Remove the inner slide member of each rail by doing the following:
Release the latch to pull out the inner slide member from the slide-rail assembly.

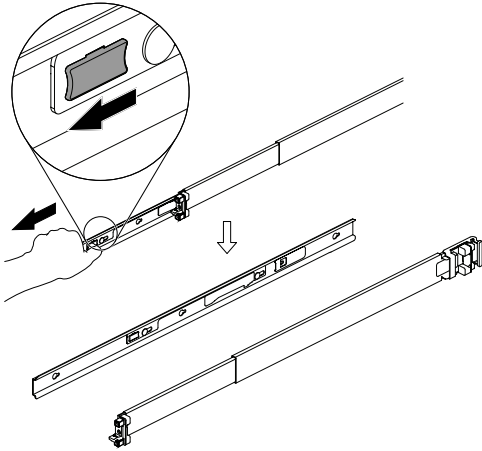

- 2.** Insert the inner slide members onto both sides of the chassis by doing the following:

Step 1. Align the four mounting holes in the inner slide member with the corresponding rail mounting points on the side of the server.

Step 2. Push the inner slide member as shown until the mounting points on the server lock into place with the inner slide member.

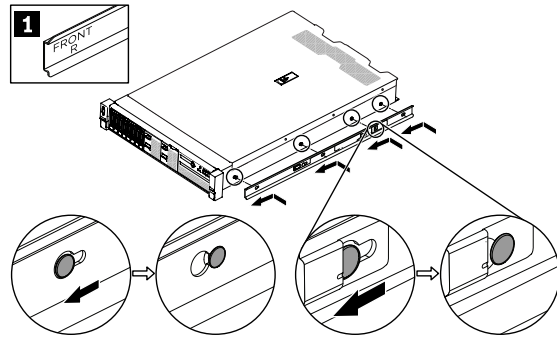

Note 1: Make sure the FRONT always face toward the front when assemble the inner slide member to the server or to the slide-rail assembly.

- 3.** Install the outer slide members to the frame by doing the following:

a. Rear mounting bracket

Step 1. Align the pins on the rear end of the outer slide member against the holes on the rear of the rack.

Step 2. Attach the rear mounting bracket to the frame, and then push the outer slide member as shown.

Step 3. Insert the tabs into the corresponding holes. The latch will lock into place afterward.

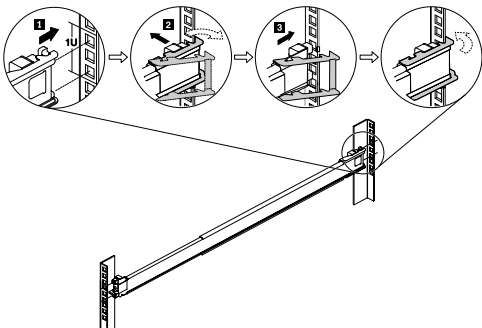

b. Front mounting bracket

Step 1. Open the front latch and align the front end of the outer slide member against the holes in the rack. Ensure that the front end and rear end of the rail are at the same horizontal level.

Step 2. Push the slide rail in the direction as shown until the tabs are inserted into the corresponding holes.

Step 3. Close the front latch to lock the rail in position.

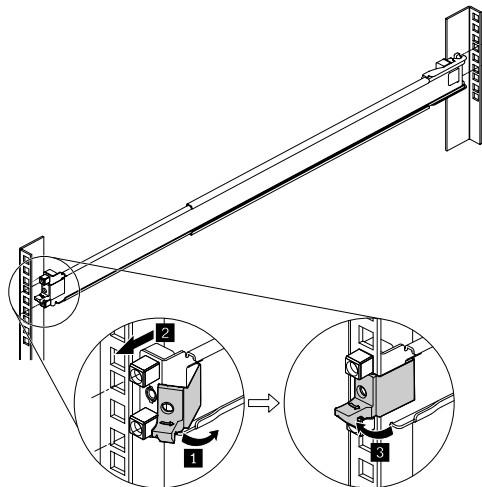

4. Insert the server to complete the installation by doing the following:

Step 1. Carefully lift the server and align the server with the slide rails. Position the server as shown and push the server into the rack.

Step 2. Pull the release latch forward.

Step 3. Push the server all the way into the rack until the server locks into place with a click.

Note: Make sure that the inner slide members are firmly inserted into the outer slide members and the server sits securely on the rails.

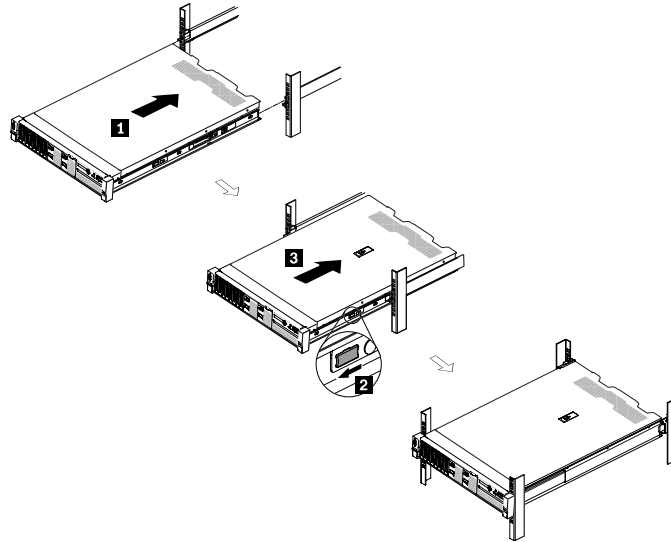

5. Install the M5 screws into the rear side to firmly secure the rail.

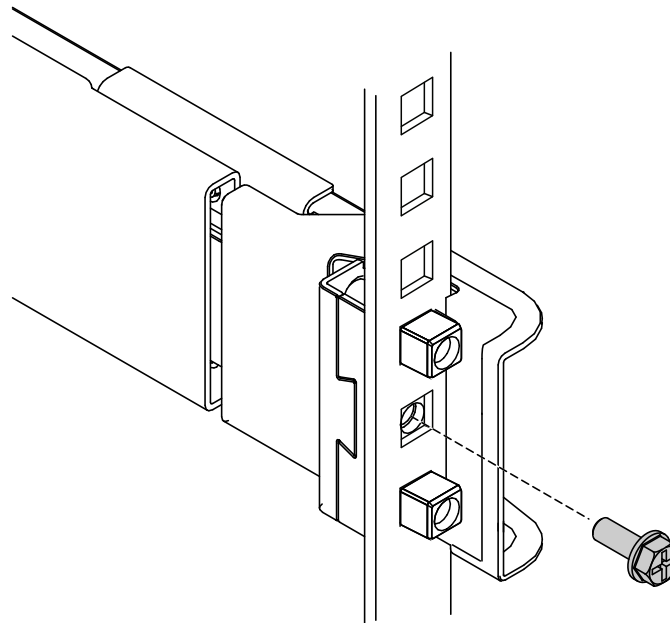

To remove a server from a rack using the ThinkSystem Toolless Friction Rail, complete the following steps:

Remove the server from the rail by doing the following:

Step 1. Disconnect all cables from the rear server. Open the rack release latch in the front of the server, then; slowly slide the server out until it stops.

Step 2. Pull the release latch forward.

Note: Make sure you read Table 1 “Safety notice” on page 2 for lifting requirements before perform step 3.

Step 3. Carefully pull the server out of the rack.

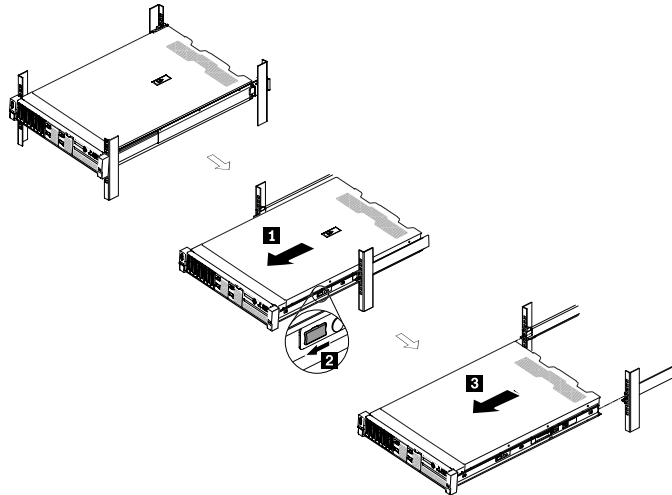

First Edition (November 2017)

© Copyright Lenovo 2017.

Lenovo and the Lenovo logo are trademarks of Lenovo in the United States, other countries, or both. Other company, product, or service names may be trademarks or service marks of others.

LIMITED AND RESTRICTED RIGHTS NOTICE: If data or software is delivered pursuant to a General Services Administration "GSA" contract, use, reproduction, or disclosure is subject to restrictions set forth in Contract No. GS-35F-05925.

Printed in China
(1P) P/N: SP47A34736

