

Cable Management Arm (CMA) Installation Guide

CMA kit parts inventory

This CMA kit is for the Toolless Slide Rail Kit.

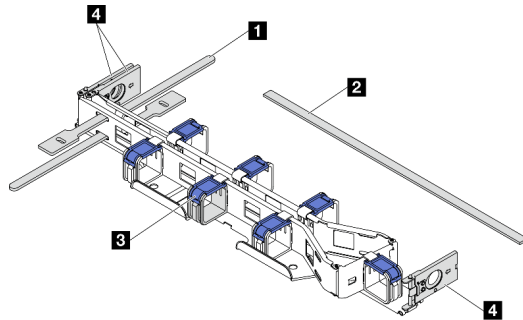

- 1** Two cable straps (pre-attached)
- 2** One long cable strap (used for shipping with a rack only)
- 3** Seven cable baskets (pre-attached)
- 4** Three slide mounting clips

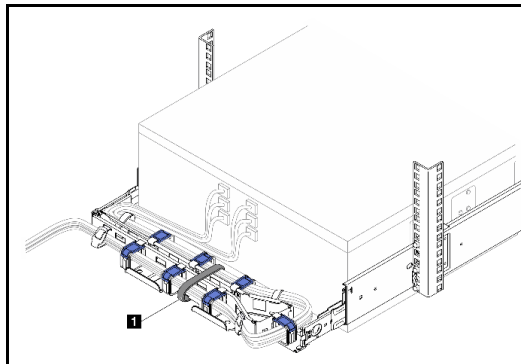

Attention: The long cable strap secures the CMA and cables in place during transportation. Unfasten the long cable strap before pulling the server out if the CMA is shipped with a rack.

- 1** Long cable strap

Install the CMA

Note: The following illustration is the CMA installation procedure for the primary chassis. The CMA installation procedure for the secondary chassis is the same, but the double mounting clip should be switched to the right side.

Step 1. Choose the mounting side for the CMA,

- If the CMA is installed to the primary chassis, proceed to step 2 directly.
- If the CMA is installed to the secondary chassis, refer to the change side guide at the end of this installation guide.

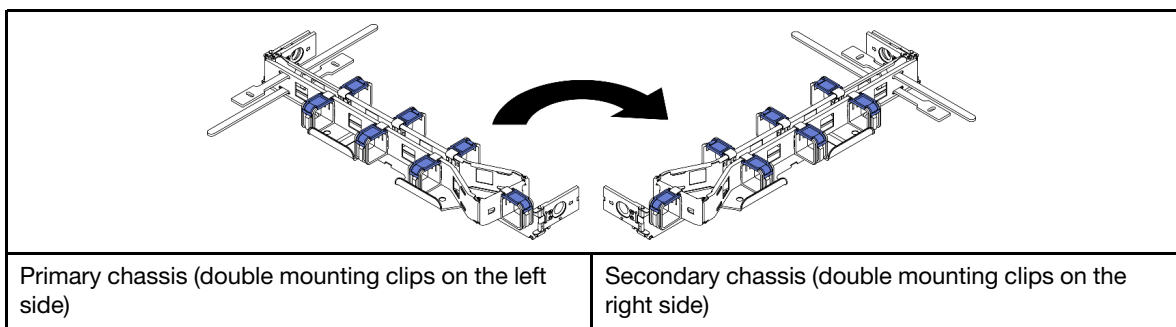

Step 2. Align the inner mounting clip with the inner tab on the slide; then, push it until it snaps into place.

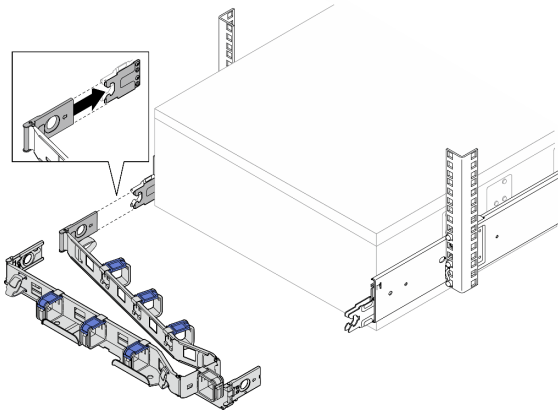

Step 3. Align two outer mounting clips with the outer tabs on the slides; then, push them until they snap into place.

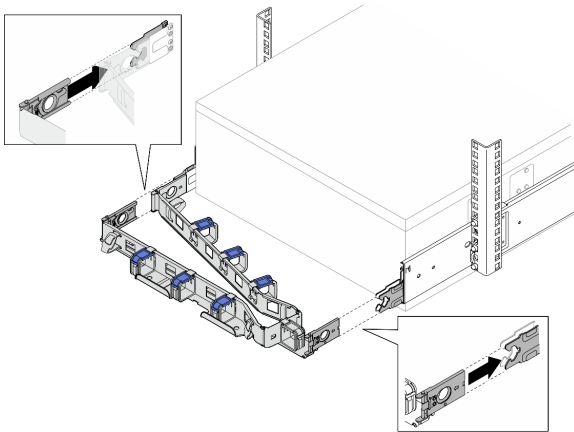

Connect and route cables

To connect and route cables, complete the following steps.

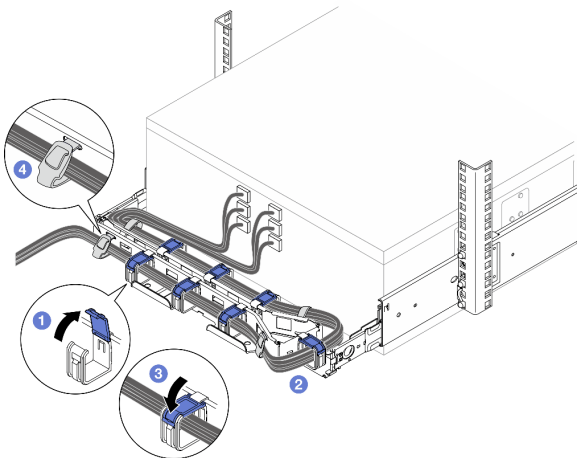

- Step 1. Open the blue retaining clips on the seven cable baskets.
- Step 2. Attach the power cords and other cables to the rear of the enclosure. Route the cables into the CMA in the direction as shown.
- Step 3. Close the blue retaining clips on the seven cable baskets.
- Step 4. Use the two cable straps to tightly secure the cables to the front and rear of the cable management arm.

Attention: Carefully slide the server back and forward to ensure the cables do not pinch, bind, or hang down into the U space directly below the server.

Remove the CMA

Note: The following illustration is the CMA removal procedure for the primary chassis. The CMA removal procedure for the secondary chassis is the same, but the double mounting clip should be switched to the right side.

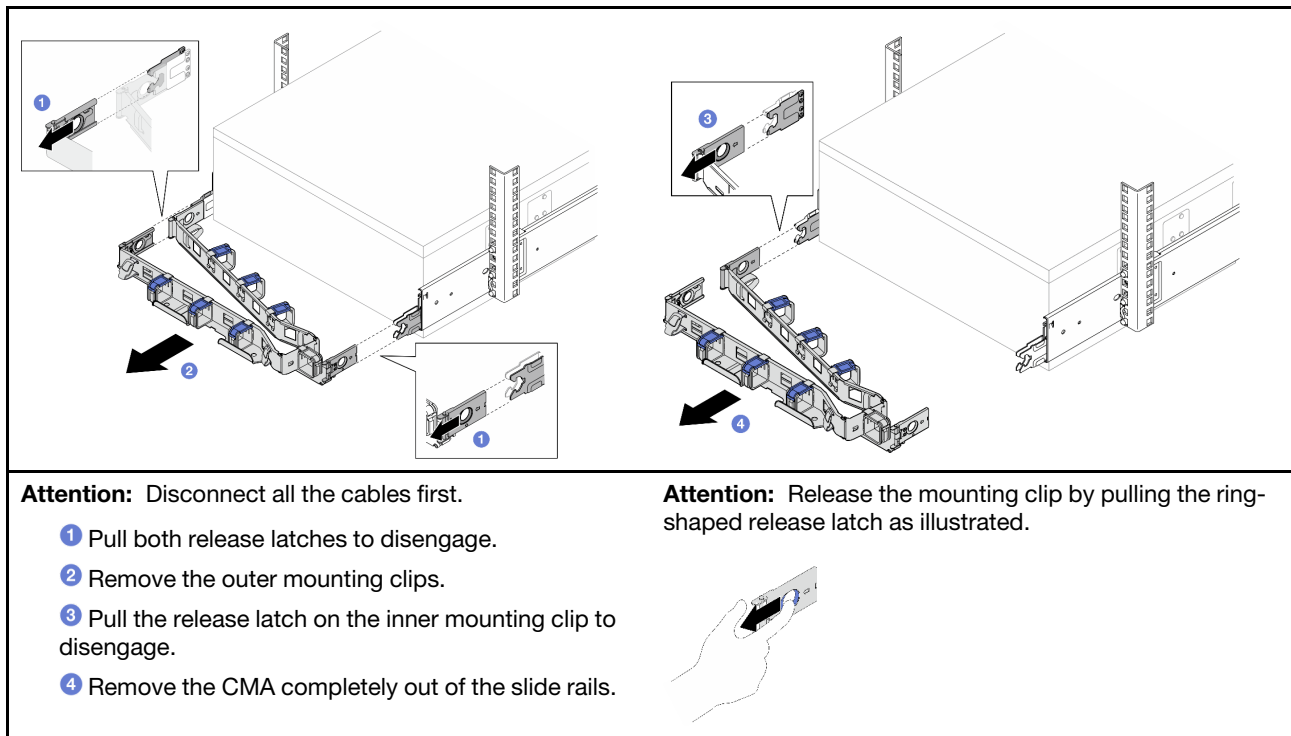

Change the CMA for installation to the other side of the rack

To install the cable management arm on the opposite side, complete the following steps:

- Step 1. Press the release latch.
- Step 2. Pull the mounting clip up to remove the cable management arm out of the shelf.
- Step 3. Press the release latch of the other mounting clip.
- Step 4. Pull the mounting clip up to remove it.

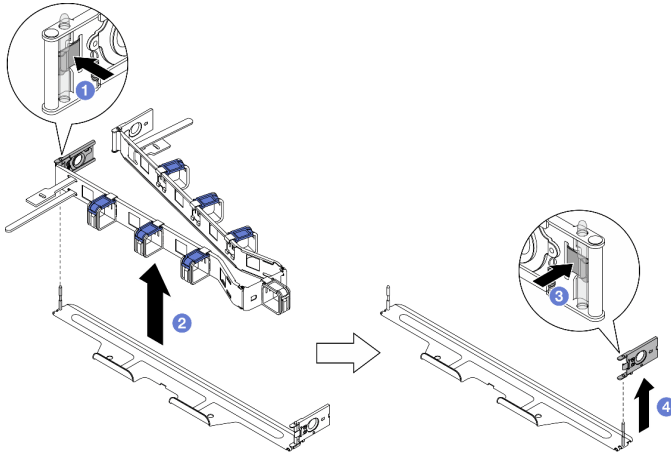

- Step 5. Align the mounting clip hole with the hinge pin; then, push the mounting clip to insert it.
- Step 6. Turn and orient the cable management arm as illustrated.
- Step 7. Align the other mounting clip hole with the hinge pin and push it to insert the cable management arm to the shelf.

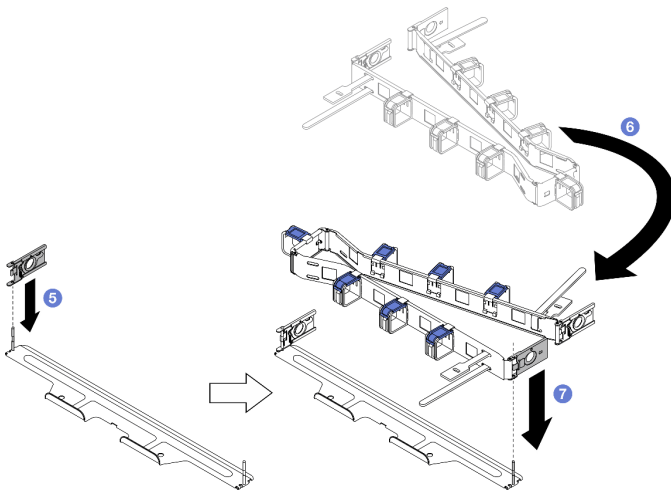

First Edition (November 2022)

© Copyright Lenovo 2022.

LIMITED AND RESTRICTED RIGHTS NOTICE: If data or software is delivered pursuant to a General Services Administration (GSA) contract, use, reproduction, or disclosure is subject to restrictions set forth in Contract No. GS-35F-05925.

Printed in China
(1P) P/N: 1PSP47B40918

