



ThinkSystem ST50 V3 System Configuration Guide



Machine Types: 7DF3, 7DF4

Note

Before using this information and the product it supports, be sure to read and understand the safety information and the safety instructions, which are available at:

https://pubs.lenovo.com/safety_documentation/

In addition, be sure that you are familiar with the terms and conditions of the Lenovo warranty for your server, which can be found at:

<http://datacentersupport.lenovo.com/warrantylookup>

Fifth Edition (October 2024)

© Copyright Lenovo 2024.

LIMITED AND RESTRICTED RIGHTS NOTICE: If data or software is delivered pursuant to a General Services Administration (GSA) contract, use, reproduction, or disclosure is subject to restrictions set forth in Contract No. GS-35F-05925.

Contents

Contents	i	Identify the server and access the Lenovo XClarity Controller	37
Safetyiii	Server setup checklist	40
Safety inspection checklist	iv	Chapter 5. System configuration	43
Chapter 1. Introduction	1	Set the network connection for the Lenovo XClarity Controller	43
Features.	1	Set USB port for Lenovo XClarity Controller connection.	43
Tech Tips	2	Update the firmware	44
Security advisories	2	Configure the firmware	48
Specifications	3	Memory module configuration	49
Technical specifications.	3	RAID configuration	49
Mechanical specifications	6	Deploy the operating system.	50
Environmental specifications	7	Back up the server configuration	51
Management options.	10	Appendix A. Getting help and technical assistance	53
Chapter 2. Server components	15	Before you call	53
Front view	15	Collecting service data	54
Rear view	18	Contacting Support	55
Side view	20	Appendix B. Documents and supports	57
Server locks	21	Documents download	57
System-board layout.	23	Support websites	57
System-board connectors	23	Appendix C. Notices.	59
System-board switches	24	Trademarks	60
System LEDs and diagnostics display	26	Important notes.	60
Troubleshooting by LEDs	26	Electronic emission notices	60
Firmware and RoT security module LEDs	26	Taiwan Region BSMI RoHS declaration	61
System-board LEDs	27	Taiwan Region import and export contact information	61
XCC system management port (10/100/1000 Mbps RJ-45) LEDs	30		
Chapter 3. Parts list	33		
Power cords	35		
Chapter 4. Unboxing and setup	37		
Server package contents	37		

Safety

Before installing this product, read the Safety Information.

قبل تركيب هذا المنتج، يجب قراءة الملاحظات الأمنية

Antes de instalar este produto, leia as Informações de Segurança.

在安装本产品之前，请仔细阅读 Safety Information（安全信息）。

安裝本產品之前，請先閱讀「安全資訊」。

Prije instalacije ovog produkta obavezno pročitajte Sigurnosne Upute.

Před instalací tohoto produktu si přečtěte příručku bezpečnostních instrukcí.

Læs sikkerhedsforskrifterne, før du installerer dette produkt.

Lees voordat u dit product installeert eerst de veiligheidsvoorschriften.

Ennen kuin asennat tämän tuotteen, lue turvaohjeet kohdasta Safety Information.

Avant d'installer ce produit, lisez les consignes de sécurité.

Vor der Installation dieses Produkts die Sicherheitshinweise lesen.

Πριν εγκαταστήσετε το προϊόν αυτό, διαβάστε τις πληροφορίες ασφάλειας (safety information).

לפני שתתקינו מוצר זה, קראו את הוראות הבטיחות.

A termék telepítése előtt olvassa el a Biztonsági előírásokat!

Prima di installare questo prodotto, leggere le Informazioni sulla Sicurezza.

製品の設置の前に、安全情報をお読みください。

본 제품을 설치하기 전에 안전 정보를 읽으십시오.

Пред да се инсталира овој продукт, прочитајте информацијата за безбедност.

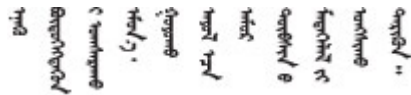

Les sikkerhetsinformasjonen (Safety Information) før du installerer dette produktet.

Przed zainstalowaniem tego produktu, należy zapoznać się z książką "Informacje dotyczące bezpieczeństwa" (Safety Information).

Antes de instalar este produto, leia as Informações sobre Segurança.

Перед установкой продукта прочтите инструкции по технике безопасности.

Pred inštaláciou tohto zariadenia si pečítajte Bezpečnostné predpisy.

Pred namestitvijo tega proizvoda preberite Varnostne informacije.

Antes de instalar este producto, lea la información de seguridad.

Läs säkerhetsinformationen innan du installerar den här produkten.

ཐོན་ཇུས་འདི་བདེ་སྤྱོད་མ་བྱས་གོང་། སྐྱོར་གྱི་ཡིད་གཟབ་
བྱ་འདྲ་མིན་ཡོད་པའི་འོད་ཟེར་བལྟ་དགོས།

Bu ürünü kurmadan önce güvenlik bilgilerini okuyun.

مەزكۇر مەھسۇلاتنى ئورنىتىشتىن بۇرۇن بىخەتەرلىك ئۇچۇرلىرىنى ئوقۇپ چىقىڭ.

Youq mwngz yungh canjbinj neix gaxgonq, itdingh aeu doeg aen
canjbinj soengq cungj vahgangj ancien siusik.

Safety inspection checklist

Use the information in this section to identify potentially unsafe conditions with your server. As each machine was designed and built, required safety items were installed to protect users and service technicians from injury.

Note: The product is not suitable for use at visual display workplaces according to §2 of the Workplace Regulations.

Note: The set-up of the server is made in the server room only.

CAUTION:

This equipment must be installed or serviced by trained personnel, as defined by the IEC 62368-1, the standard for Safety of Electronic Equipment within the Field of Audio/Video, Information Technology and Communication Technology. Lenovo assumes you are qualified in the servicing of equipment and trained in recognizing hazards energy levels in products. Access to the equipment is by the use of a tool, lock and key, or other means of security, and is controlled by the authority responsible for the location.

Important: Electrical grounding of the server is required for operator safety and correct system function. Proper grounding of the electrical outlet can be verified by a certified electrician.

Use the following checklist to verify that there are no potentially unsafe conditions:

1. Make sure that the power is off and the power cord is disconnected.
2. Check the power cord.
 - Make sure that the third-wire ground connector is in good condition. Use a meter to measure third-wire ground continuity for 0.1 ohm or less between the external ground pin and the frame ground.
 - Make sure that the power cord is the correct type.

To view the power cords that are available for the server:

- a. Go to:

<http://dcsc.lenovo.com/#/>

- b. Click **Preconfigured Model** or **Configure to order**.
- c. Enter the machine type and model for your server to display the configurator page.
- d. Click **Power → Power Cables** to see all line cords.
 - Make sure that the insulation is not frayed or worn.
3. Check for any obvious non-Lenovo alterations. Use good judgment as to the safety of any non-Lenovo alterations.
4. Check inside the server for any obvious unsafe conditions, such as metal filings, contamination, water or other liquid, or signs of fire or smoke damage.
5. Check for worn, frayed, or pinched cables.
6. Make sure that the power-supply cover fasteners (screws or rivets) have not been removed or tampered with.

Chapter 1. Introduction

The ThinkSystem ST50 V3 server (Types 7DF3 and 7DF4) stands as a robust entry-level server tailored for growing businesses seeking to manage IT infrastructure and business applications. Supporting the latest Intel® Xeon® E-2400 processor, DDR5 memory, and PCIe Gen 5, it delivers the necessary performance for handling the IT infrastructure of a remote or home office.

With the compact size and low-decibel noise level, it is ideal for installation outside of a traditional data center. As your business expands, it offers the flexibility to transition into a data center environment seamlessly.

Note: ThinkSystem ST50 V3 is model for the global market, while ST58 V3 is only sold in Chinese Mainland.

Figure 1. ThinkSystem ST50 V3

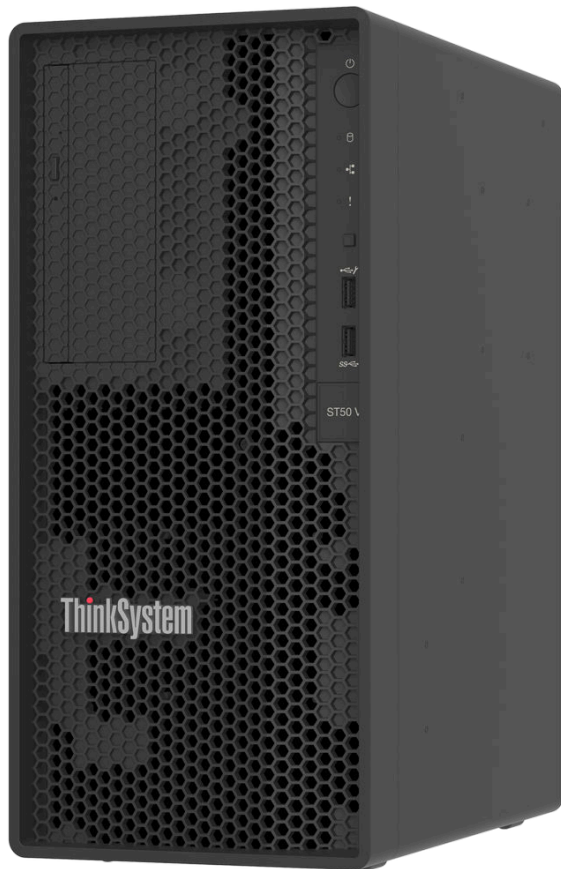

Features

Performance, ease of use, reliability, and expansion capabilities were key considerations in the design of your server. These design features make it possible for you to customize the system hardware to meet your needs today and provide flexible expansion capabilities for the future.

Your server implements the following features and technologies:

- **Lenovo XClarity Controller (XCC)**

The Lenovo XClarity Controller is the common management controller for Lenovo ThinkSystem server hardware. The Lenovo XClarity Controller consolidates multiple management functions in a single chip on the server system board (system board assembly). Some of the features that are unique to the Lenovo XClarity Controller are enhanced performance, higher-resolution remote video, and expanded security options.

The server supports Lenovo XClarity Controller 2 (XCC2). For additional information about Lenovo XClarity Controller 2 (XCC2), refer to <https://pubs.lenovo.com/lxcc-overview/>.

- **UEFI-compliant server firmware**

Lenovo ThinkSystem firmware is Unified Extensible Firmware Interface (UEFI) compliant. UEFI replaces BIOS and defines a standard interface between the operating system, platform firmware, and external devices.

Lenovo ThinkSystem servers are capable of booting UEFI-compliant operating systems, BIOS-based operating systems, and BIOS-based adapters as well as UEFI-compliant adapters.

Note: The server does not support Disk Operating System (DOS).

- **Large system-memory capacity**

The server supports error-correcting code unbuffered DIMM (ECC UDIMM). For more information about the specific types and maximum amount of memory, see “[Technical specifications](#)” on page 3.

- **Large data-storage capacity and hot-swap capability**

The server support a maximum of four drives and one slim SATA optical disk drive.

- **Mobile access to Lenovo Service Information website**

The server provides a QR code on the system service label, which is on the cover of the server, that you can scan using a QR code reader and scanner with a mobile device to get quick access to the Lenovo Service Information website. The Lenovo Service Information website provides additional information for parts installation, replacement videos, and error codes for server support.

- **Tremendous durability**

The system has been verified to run even enterprise workload, 24/7.

Tech Tips

Lenovo continually updates the support website with the latest tips and techniques that you can use to solve issues that your server might encounter. These Tech Tips (also called retain tips or service bulletins) provide procedures to work around issues or solve problems related to the operation of your server.

To find the Tech Tips available for your server:

1. Go to <http://datacentersupport.lenovo.com> and navigate to the support page for your server.
2. Click on **How To's** from the navigation pane.
3. Click **Article Type** → **Solution** from the drop-down menu.

Follow the on-screen instructions to choose the category for the problem that you are having.

Security advisories

Lenovo is committed to developing products and services that adhere to the highest security standards in order to protect our customers and their data. When potential vulnerabilities are reported, it is the responsibility of the Lenovo Product Security Incident Response Team (PSIRT) to investigate and provide information to our customers so they may put mitigation plans in place as we work toward providing solutions.

The list of current advisories is available at the following site:

https://datacentersupport.lenovo.com/product_security/home

Specifications

Summary of the features and specifications of the server. Depending on the model, some features might not be available, or some specifications might not apply.

Refer to the below table for specifications categories and the content of each category.

Specification category	Technical specifications	Mechanical specifications	Environmental specifications
Content	<ul style="list-style-type: none"> • Processor • Memory • M.2 Drive • Storage expansion • Expansion slots • Integrated functions and I/O connectors • Network • Rear button • RAID adapter • Host bus adapter • System fan • Electrical input • Minimal configuration for debugging • Operating systems 	<ul style="list-style-type: none"> • Dimension • Weight 	<ul style="list-style-type: none"> • Heat output • Acoustical noise emissions • Ambient temperature management • Environmental

Technical specifications

Summary of the technical specifications of server. Depending on the model, some features might not be available, or some specifications might not apply.

Processor
<ul style="list-style-type: none"> • The server supports one of the following Intel® processors: <ul style="list-style-type: none"> – Xeon® E – Pentium® <p>Note: Only the Xeon® E processor supports Intel® Trusted Execution Technology (Intel® TXT) feature.</p> <ul style="list-style-type: none"> • Designed for LGA 1700 socket • Scalable up to 8 cores per socket • Supports TDP up to 95W <p>For a list of supported processors, see https://serverproven.lenovo.com.</p>

Memory

See “Memory module installation rules and order” in *User Guide* or *Hardware Maintenance Guide* for detailed information about memory configuration and setup.

- Minimum: 16 GB
- Maximum: 128 GB
- Slots: four DIMM slots (two channels, two DIMMs per channel)
- Memory module type:
 - TruDDR5 4800MHz (1Rx8) ECC UDIMM: 16 GB (1Rx8)
 - TruDDR5 4800MHz (2Rx8) ECC UDIMM: 32 GB (2Rx8)

Note: Memory operates at up to 4400 MHz, depending on the processor selected and DIMM population order.

For a list of supported memory modules, see <https://serverproven.lenovo.com>.

M.2 Drive

The server supports up to two SATA M.2 drives of the following drive form factors:

- 42 mm (2242)
- 60 mm (2260)
- 80 mm (2280)
- 110 mm (22110)

Supports the following M.2 drive capacity:

- 240 GB
- 480 GB
- 960 GB

Note: Both the M.2 kit and drive bay 3 occupy PCIe slot 3 and therefore cannot be installed in the same system.

For a list of supported M.2 drives, see <https://serverproven.lenovo.com>.

Storage expansion

The server supports three 3.5-inch drive bays (two for optional), one 2.5-inch drive bay (optional), one ODD bay (optional).

- Drive bay 0
 - 3.5-inch hard-disk drive or solid-state drive
- Drive bay 1 (optional)
 - 2.5-inch hard-disk drive or solid-state drive
- Drive bay 2 (optional)
 - 3.5-inch hard-disk drive or solid-state drive
- Drive bay 3 (optional)
 - 3.5-inch hard-disk drive or solid-state drive

Note: Both the M.2 kit and drive bay 3 occupy PCIe slot 3 and therefore cannot be installed in the same system.

- ODD drive bay (optional)
 - One 9mm slim SATA Optical disk drive

For a list of supported drives, see <https://serverproven.lenovo.com>.

Expansion slots

Three PCIe expansion slots are available:

- PCIe slot 1: PCIe Gen4 x4, FH/HL, 25W
- PCIe slot 2: PCIe Gen5 x16, FH/HL, 75W
- PCIe slot 3: PCIe Gen4 x4, FH/HL, 25W

Note: Slot 1 and Slot 3 in the ST50 V3 are open-end design, which means that the slots can accept adapters with a longer edge connector than the physical length of the slot connector. For example, if a x8 adapter is installed in the x4 slot 3 of the server, half of the edge connector will not be connected to the slot. The adapter will still function, but performance will be impacted.

Integrated functions and I/O connectors

- Lenovo XClarity Controller (XCC), which provides service processor control and monitoring functions, video controller, and remote keyboard, video, mouse, and remote drive capabilities.
 - The server supports Lenovo XClarity Controller 2 (XCC2). For additional information about Lenovo XClarity Controller 2 (XCC2), refer to <https://pubs.lenovo.com/lxcc-overview/>.
- Front connectors:
 - One USB 3.2 Gen 1 (5 Gbps) connector
 - One USB 2.0 connector with XCC mobile support
- Rear connectors:
 - One serial port
 - One VGA connector
 - One XCC system management port (10/100/1000 Mbps RJ-45)
 - Two Ethernet connectors (Ethernet connector 1 shared with Lenovo XClarity Controller network connector)
 - Four USB 3.2 Gen 1 (5 Gbps) connectors

Note: The maximum video resolution is 1920 x 1200 at 60 Hz.

Network

- Two 1 Gbps RJ45 Ethernet connectors
- One 1 Gbps RJ45 Lenovo XClarity Controller network connector

Rear button

NMI button

RAID adapter

The following options are available for this server.

- Hardware RAID (RAID level 0, 1, and 5)
 - ThinkSystem RAID 5350-8i PCIe 12Gb Adapter
- Software RAID (RAID level 0, 1, and 5)
 - Intel VROC SATA RAID

For more information about the RAID/HBA adapters, see [Lenovo ThinkSystem RAID Adapter and HBA Reference](#).

Host bus adapter

- ThinkSystem 4350-8i SAS/SATA 12Gb HBA

For more information about the RAID/HBA adapters, see [Lenovo ThinkSystem RAID Adapter and HBA Reference](#).

System fan

The server supports up to three fans:

- When processor TDP is lower than 95 watts
 - One front fan
 - One rear fan (only when drive bay 2 and/or M.2 kit is installed)
 - One processor heat sink fan
- When processor TDP is 95 watts
 - One front fan
 - One processor heat sink fan

Electrical input

The server supports one of the following non-hot-swap, non-redundant power supplies:

- Fixed ATX 300-watt Single-Output Gold
 - Input power 115 Vac or 230 Vac
- Fixed ATX 500-watt Multi-Output Platinum
 - Input power 115 Vac or 230 Vac

Minimal configuration for debugging

- One processor and one processor cooling heat sink
- One 16 GB ECC UDIMM in DIMM slot 3
- One power supply
- One 3.5-inch SATA drive in drive bay 0 (if OS is needed by debugging)
- One system front fan (if debugging is out of chassis)

Operating systems

Supported and certified operating systems:

- Microsoft Windows Server
- VMware ESXi
- Red Hat Enterprise Linux
- SUSE Linux Enterprise Server

References:

- Complete list of available operating systems: <https://lenovopress.lenovo.com/osig>.
- OS deployment instructions, see “Deploy the operating system” on page 50.

Mechanical specifications

Summary of the mechanical specifications of server. Depending on the model, some features might not be available, or some specifications might not apply.

Dimension

4U server

- Width: 170 mm (6.7 inches)
- Height:
 - With stands: 376 mm (14.8 inches)
 - Without stands: 370 mm (14.6 inches)
- Depth: 315.4 mm (12.4 inches)

Weight

Net weight: up to 9.5 kg (20.94 lb) depending upon configuration

Environmental specifications

Summary of the environmental specifications of server. Depending on the model, some features might not be available, or some specifications might not apply.

Heat output

Approximate heat output:

- Minimum configuration: 354 BTU per hour (104 watts)
- Maximum configuration : 1009 BTU per hour (296 watts)

Acoustical noise emissions

The server has the following acoustic noise emissions declaration:

- Sound power level (L_{WAd})
 - Idling: 3.4 Bel (Typical), 4.0 Bel (Max.)
 - Operating 1: 3.4 Bel (Typical), 4.0 Bel (Max.)
 - Operating 2: 4.8 Bel (Typical), 5.4 Bel (Max.)
- Sound pressure level (L_{pAm}):
 - Idling: 20.3 dBA (Typical), 27.6 dBA (Max.)
 - Operating 1: 20.3 dBA (Typical), 27.6 dBA (Max.)
 - Operating 2: 35.1 dBA (Typical), 40.6 dBA (Max.)

Notes:

- These sound levels were measured in controlled acoustical environments according to procedures specified by ISO 7779 and are reported in accordance with ISO 9296. Testing was conducted at $23^{\circ}\text{C} \pm 2^{\circ}\text{C}$ to align with ISO7779 procedures.
- Idling mode is the steady state in which the server is powered on but not operating any intended function. Operating mode 1 is 50% CPU TDP. Operating mode 2 is 100% CPU TDP.
- The declared acoustic sound levels are based on the following configurations, which may change depending on configuration/conditions:
 - Typical: 1x 80 W CPU, 1x 16 GB DIMM, 1x 3.5" HDD, 1x Slim SATA ODD, 1x 300 W fixed PSU
 - Maximum: 1x 95 W CPU, 4x 32 GB DIMM, 3x 3.5" HDD, 1x 2.5" SSD, 1x Slim SATA ODD, 1x 5350-8i RAID, 1x 1G NIC, 1x 500 W fixed PSU
- Government regulations (such as those prescribed by OSHA or European Community Directives) may govern noise level exposure in the workplace and may apply to you and your server installation. The actual sound pressure levels in your installation depend upon a variety of factors, including the number of racks in the installation; the size, materials, and configuration of the room; the noise levels from other equipment; the room ambient temperature, and employee's location in relation to the equipment. Further, compliance with such government regulations depends on a variety of additional factors, including the duration of employees' exposure and whether employees wear hearing protection. Lenovo recommends that you consult with qualified experts in this field to determine whether you are in compliance with the applicable regulations.

Ambient temperature management

Important: When the ambient temperature is greater than the supported temperature, the server will shut down. The server will not power on again until the ambient temperature falls within the supported temperature range. The ambient temperature must be 35°C or lower if the server has any of the following components:

- M.2 drives (960 GB or below)

Environment

ThinkSystem ST50 V3 complies with ASHRAE Class A2 specifications. System performance may be impacted when the operating temperature is outside AHSARE A2 specification.

- Air temperature:
 - Operating
 - ASHRAE Class A2: 10°C to 35°C (50°F to 95°F); the maximum ambient temperature decreases by 1°C for every 300 m (984 ft) increase in altitude above 900 m (2,953 ft).
 - Server off: 5°C to 45°C (41°F to 113°F)
 - Shipment/storage: -20°C to 60°C (-4°F to 140°F)
- Maximum altitude: 3,050 m (10,000 ft)
- Relative Humidity (non-condensing):
 - Operating
 - ASHRAE Class A2: 8% to 80%; maximum dew point: 21°C (70°F)
 - Shipment/storage: 8% to 90%
- Particulate contamination

Attention: Airborne particulates and reactive gases acting alone or in combination with other environmental factors such as humidity or temperature might pose a risk to the server. For information about the limits for particulates and gases, see [“Particulate contamination” on page 9](#).

Note: The server is designed for standard data center environment and recommended to be placed in industrial data center.

Particulate contamination

Attention: Airborne particulates (including metal flakes or particles) and reactive gases acting alone or in combination with other environmental factors such as humidity or temperature might pose a risk to the device that is described in this document.

Risks that are posed by the presence of excessive particulate levels or concentrations of harmful gases include damage that might cause the device to malfunction or cease functioning altogether. This specification sets forth limits for particulates and gases that are intended to avoid such damage. The limits must not be viewed or used as definitive limits, because numerous other factors, such as temperature or moisture content of the air, can influence the impact of particulates or environmental corrosives and gaseous contaminant transfer. In the absence of specific limits that are set forth in this document, you must implement practices that maintain particulate and gas levels that are consistent with the protection of human health and safety. If Lenovo determines that the levels of particulates or gases in your environment have caused damage to the device, Lenovo may condition provision of repair or replacement of devices or parts on implementation of appropriate remedial measures to mitigate such environmental contamination. Implementation of such remedial measures is a customer responsibility.

Table 1. Limits for particulates and gases

Contaminant	Limits
Reactive gases	<p>Severity level G1 as per ANSI/ISA 71.04-1985¹:</p> <ul style="list-style-type: none"> • The copper reactivity level shall be less than 200 Angstroms per month ($\text{\AA}/\text{month} \approx 0.0035 \mu\text{g}/\text{cm}^2\text{-hour}$ weight gain).² • The silver reactivity level shall be less than 200 Angstroms per month ($\text{\AA}/\text{month} \approx 0.0035 \mu\text{g}/\text{cm}^2\text{-hour}$ weight gain).³ • The reactive monitoring of gaseous corrosivity must be conducted approximately 5 cm (2 in.) in front of the rack on the air inlet side at one-quarter and three-quarter frame height off the floor or where the air velocity is much higher.
Airborne particulates	<p>Data centers must meet the cleanliness level of ISO 14644-1 class 8.</p> <p>For data centers without airside economizer, the ISO 14644-1 class 8 cleanliness might be met by choosing one of the following filtration methods:</p> <ul style="list-style-type: none"> • The room air might be continuously filtered with MERV 8 filters. • Air entering a data center might be filtered with MERV 11 or preferably MERV 13 filters. <p>For data centers with airside economizers, the choice of filters to achieve ISO class 8 cleanliness depends on the specific conditions present at that data center.</p> <ul style="list-style-type: none"> • The deliquescent relative humidity of the particulate contamination should be more than 60% RH.⁴ • Data centers must be free of zinc whiskers.⁵

¹ ANSI/ISA-71.04-1985. *Environmental conditions for process measurement and control systems: Airborne contaminants*. Instrument Society of America, Research Triangle Park, North Carolina, U.S.A.

² The derivation of the equivalence between the rate of copper corrosion growth in the thickness of the corrosion product in $\text{\AA}/\text{month}$ and the rate of weight gain assumes that Cu_2S and Cu_2O grow in equal proportions.

³ The derivation of the equivalence between the rate of silver corrosion growth in the thickness of the corrosion product in $\text{\AA}/\text{month}$ and the rate of weight gain assumes that Ag_2S is the only corrosion product.

⁴ The deliquescent relative humidity of particulate contamination is the relative humidity at which the dust absorbs enough water to become wet and promote ionic conduction.

⁵ Surface debris is randomly collected from 10 areas of the data center on a 1.5 cm diameter disk of sticky electrically conductive tape on a metal stub. If examination of the sticky tape in a scanning electron microscope reveals no zinc whiskers, the data center is considered free of zinc whiskers.

Management options

The XClarity portfolio and other system management options described in this section are available to help you manage the servers more conveniently and efficiently.

Overview

Options	Description
Lenovo XClarity Controller	<p>Baseboard management controller (BMC)</p> <p>Consolidates the service processor functionality, Super I/O, video controller, and remote presence capabilities into a single chip on the server system board (system board assembly).</p> <p>Interface</p> <ul style="list-style-type: none"> • CLI application • Web GUI interface • Mobile application • Redfish API <p>Usage and downloads</p> <p>https://pubs.lenovo.com/lxcc-overview/</p>
Lenovo XCC Logger Utility	<p>Application that reports the XCC events to local OS system log.</p> <p>Interface</p> <ul style="list-style-type: none"> • CLI application <p>Usage and downloads</p> <ul style="list-style-type: none"> • https://pubs.lenovo.com/lxcc-logger-linux/ • https://pubs.lenovo.com/lxcc-logger-windows/
Lenovo XClarity Administrator	<p>Centralized interface for multi-server management.</p> <p>Interface</p> <ul style="list-style-type: none"> • Web GUI interface • Mobile application • REST API <p>Usage and downloads</p> <p>https://pubs.lenovo.com/lxca/</p>
Lenovo XClarity Essentials toolset	<p>Portable and light toolset for server configuration, data collection, and firmware updates. Suitable both for single-server or multi-server management contexts.</p> <p>Interface</p> <ul style="list-style-type: none"> • OneCLI: CLI application • Bootable Media Creator: CLI application, GUI application • UpdateXpress: GUI application <p>Usage and downloads</p> <p>https://pubs.lenovo.com/lxce-overview/</p>

Options	Description
Lenovo XClarity Provisioning Manager	<p>UEFI-based embedded GUI tool on a single server that can simplify management tasks.</p> <p>Interface</p> <ul style="list-style-type: none"> • Web interface (BMC remote access) • GUI application <p>Usage and downloads</p> <p>https://pubs.lenovo.com/lxpm-overview/</p> <p>Important: Lenovo XClarity Provisioning Manager (LXPM) supported version varies by product. All versions of Lenovo XClarity Provisioning Manager are referred to as Lenovo XClarity Provisioning Manager and LXPM in this document, unless specified otherwise. To see the LXPM version supported by your server, go to https://pubs.lenovo.com/lxpm-overview/.</p>
Lenovo XClarity Integrator	<p>Series of applications that integrate the management and monitoring functionalities of the Lenovo physical servers with the software used in a certain deployment infrastructure, such as VMware vCenter, Microsoft Admin Center, or Microsoft System Center while delivering additional workload resiliency.</p> <p>Interface</p> <ul style="list-style-type: none"> • GUI application <p>Usage and downloads</p> <p>https://pubs.lenovo.com/lxci-overview/</p>
Lenovo XClarity Energy Manager	<p>Application that can manage and monitor server power and temperature.</p> <p>Interface</p> <ul style="list-style-type: none"> • Web GUI Interface <p>Usage and downloads</p> <p>https://datacentersupport.lenovo.com/solutions/Invo-lxem</p>
Lenovo Capacity Planner	<p>Application that supports power consumption planning for a server or rack.</p> <p>Interface</p> <ul style="list-style-type: none"> • Web GUI Interface <p>Usage and downloads</p> <p>https://datacentersupport.lenovo.com/solutions/Invo-lcp</p>

Functions

Options		Functions							
		Multi-system mgmt	OS deployment	System configuration	Firmware updates ¹	Event/alert monitoring	Inventory/logs	Power mgmt	Power planning
Lenovo XClarity Controller				√	√ ²	√	√ ⁴		
Lenovo XCC Logger Utility						√			
Lenovo XClarity Administrator		√	√	√	√ ²	√	√ ⁴		
Lenovo XClarity Essentials toolset	OneCLI	√		√	√ ²	√	√		
	Bootable Media Creator			√	√ ²		√ ⁴		
	UpdateXpress			√	√ ²				
Lenovo XClarity Provisioning Manager			√	√	√ ³		√ ⁵		
Lenovo XClarity Integrator		√	√ ⁶	√	√	√	√	√ ⁷	
Lenovo XClarity Energy Manager		√				√		√	
Lenovo Capacity Planner									√ ⁸

Notes:

1. Most options can be updated through the Lenovo tools. Some options, such as GPU firmware or Omni-Path firmware require the use of supplier tools.
2. The server UEFI settings for option ROM must be set to **Auto** or **UEFI** to update firmware using Lenovo XClarity Administrator, Lenovo XClarity Essentials, or Lenovo XClarity Controller.
3. Firmware updates are limited to Lenovo XClarity Provisioning Manager, Lenovo XClarity Controller, and UEFI updates only. Firmware updates for optional devices, such as adapters, are not supported.
4. The server UEFI settings for option ROM must be set to **Auto** or **UEFI** for detailed adapter card information, such as model name and firmware levels, to be displayed in Lenovo XClarity Administrator, Lenovo XClarity Controller, or Lenovo XClarity Essentials.
5. Limited inventory.
6. The Lenovo XClarity Integrator deployment check for System Center Configuration Manager (SCCM) supports Windows operating system deployment.
7. Power management function is supported only by Lenovo XClarity Integrator for VMware vCenter.
8. It is highly recommended that you check the power summary data for your server using Lenovo Capacity Planner before purchasing any new parts.

Chapter 2. Server components

This section contains information about each of the components associated with the server.

Front view

This section contains information about the controls, LEDs, and connectors on the front of the server.

Front view of the sever components

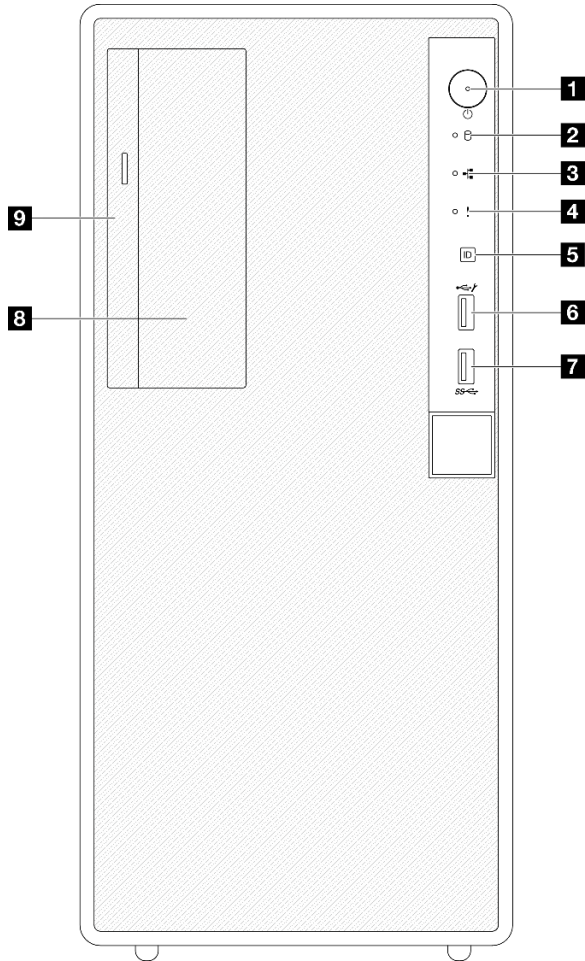

Figure 2. Front view of the sever components

Table 2. Components on the front view

1 Power button/LED (green)	6 USB 2.0 connector with Lenovo XClarity Controller management
2 Drive activity LED (green) Note: For onboard SATA indication only	7 USB 3.2 Gen 1 (5Gbps) connector
3 Network activity LED (green)	8 3.5-inch drive bay

Table 2. Components on the front view (continued)

4 System error LED (yellow)	9 Optical-drive bay
5 System ID button LED (blue)	

1 Power button/LED (green)

Press this button to turn the server on and off manually. The states of the power LED are as follows:

Status	Color	Description
Off	None	Power is not present, or the power supply has failed.
Fast blinking (about four flashes per second)	Green	<ul style="list-style-type: none"> The server is off, but the XClarity Controller is initializing, and the server is not ready to be powered on. System-board-assembly power has failed.
Slow blinking (about one flash per second)	Green	The server is off and is ready to be powered on (standby state).
Solid on	Green	The server is on and running.

2 Drive activity LED (green)

This LED indicates the activity of the drives.

Status	Color	Description
Blinking	Green	The drives are active.
Off	None	The drives are not active.

3 Network Activity LED (green)

The network activity LED helps you identify the network connectivity and activity.

Status	Color	Description
Blinking	Green	The network is connected and active.
Off	None	The server is disconnected from the network.

4 System error LED (yellow)

The system error LED helps you to determine if there are any system errors.

Status	Color	Description	Action
On	Yellow	<p>An error has been detected on the server. Causes might include one or more of the following errors:</p> <ul style="list-style-type: none"> • The temperature of the server reached the non-critical temperature threshold. • The voltage of the server reached the non-critical voltage threshold. • A fan has been detected to be running at low speed. • The power supply has a critical error. • The power supply is not connected to the power. 	Check system logs or internal error LEDs to identify the failed part.
Off	None	The server is off or the server is on and is working correctly.	None.

5 System ID button/LED (blue)

Use this system ID button and the blue system ID LED to visually locate the server. Each time you press the system ID button, the state of the system ID LED changes. The LED can be changed to on, blinking, or off. You can also use the Lenovo XClarity Controller or a remote management program to change the state of the system ID LED to assist in visually locating the server among other servers.

6 USB 2.0 connector with Lenovo XClarity Controller management

Connect a USB 2.0 device, such as a mouse, keyboard, or other devices, to this connector.

Note: This is the only USB port that supports USB automation update of the firmware and RoT security module.

Connection to Lenovo XClarity Controller is primarily intended for users with a mobile device running the Lenovo XClarity Controller mobile application. When a mobile device is connected to this USB port, an Ethernet over USB connection is established between the mobile application running on the device and the Lenovo XClarity Controller.

Select **Network** in **BMC Configuration** to view or modify settings.

Four types of settings are available:

- **Host only mode**

In this mode, the USB port is always solely connected to the server.

- **BMC only mode**

In this mode, the USB port is always solely connected to Lenovo XClarity Controller.

- **Shared mode: owned by BMC**

In this mode, connection to the USB port is shared by the server and Lenovo XClarity Controller, while the port is switched to Lenovo XClarity Controller.

- **Shared mode: owned by host**

In this mode, connection to the USB port is shared by the server and Lenovo XClarity Controller, while the port is switched to the server.

7 USB 3.2 Gen 1 (5 Gbps) connector

The USB 3.2 Gen 1 (5 Gbps) connector can be used to attach a USB-compatible device, such as a USB keyboard, USB mouse, or USB storage device.

8 3.5-inch drive bay

Depending on the model, the server might come with a 3.5-inch drive installed in this drive bay. See “Install a simple-swap drive (bay 2)” in *User Guide* or *Hardware Maintenance Guide* for more details.

9 Optical drive bay

Depending on the model, the server might come with an optical drive installed in the optical drive bay. See “Optical drive and drive cage replacement” in *User Guide* or *Hardware Maintenance Guide* for more details.

Rear view

This section contains information about the important components on the rear of this server.

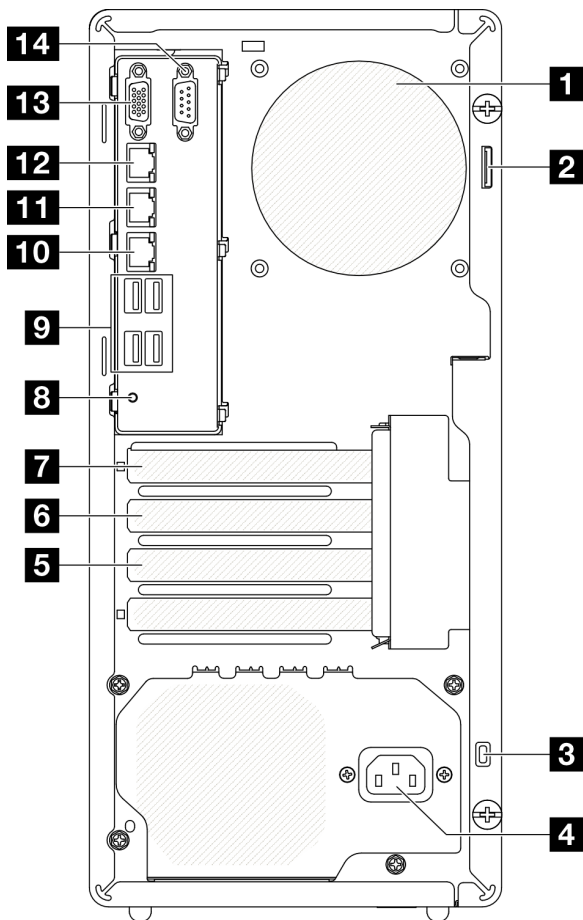

Figure 3. Rear view

1 Rear fan	8 NMI button
2 Padlock loop	9 USB 3.2 Gen 1 (5 Gbps) connectors (total of four connectors)
3 Kensington lock	10 Ethernet connector 2

4 Power cord connector	11 Ethernet connector 1 (shared with XCC network port)
5 PCIe slot 3	12 XCC system management port (10/100/1000 Mbps RJ-45)
6 PCIe slot 2	13 VGA connector
7 PCIe slot 1	14 Serial port

1 Rear fan

Install the rear fan in this space.

2 Padlock loop

This loop is available for installing a padlock. See [“Server locks” on page 21](#) for more information.

3 Kensington lock

This loop is available for installing a Kensington lock. See [“Server locks” on page 21](#) for more information.

4 Power cord connector

Connect the power cord to this component.

5/6/7 PCIe slots

There are three PCIe slots on the system board to install appropriate PCIe adapters. For information about the PCIe slots, see [“Specifications” on page 3](#).

8 NMI button

Press this button to force a nonmaskable interrupt to the processor. You might have to use a pen or the end of a straightened paper clip to press the button. You can also use it to force a blue-screen memory dump. Use this button only when you are directed to do so by Lenovo Support.

9 USB 3.2 Gen 1 (5 Gbps) connectors

There are four USB 3.2 Gen 1 (5 Gbps) connectors on the rear of the server. Connect a USB device, such as a mouse, keyboard, or other devices, to either of these connectors.

10 Ethernet connector 2

Attach an Ethernet cable for LAN. Each Ethernet connector has two status LEDs to help you identify the Ethernet connectivity and activity.

11 Ethernet connector 1 (shared with XCC network port)

Attach an Ethernet cable for LAN. Each Ethernet connector has two status LEDs to help you identify the Ethernet connectivity and activity. If the LOM adapter is not installed, Ethernet connector 1 can be set as Lenovo XClarity Controller Network connector.

To set Ethernet connector 1 as Lenovo XClarity Controller Network connector, start Setup Utility and select **BMC Settings → Network Settings → Network Interface Port : Shared**. Then, click **Shared NIC on** and select **Share OnLom Port:01**.

12 XCC system management port (10/100/1000 Mbps RJ-45)

The server has a 10/100/1000 Mbps RJ-45 connector dedicated to Lenovo XClarity Controller (XCC) functions. Through the system management port, you can access the Lenovo XClarity Controller directly by connecting your laptop to the management port using an Ethernet cable. Make sure that you modify the IP settings on the laptop so that it is on the same network as the server default settings. A dedicated

management network provides additional security by physically separating the management network traffic from the production network.

See the following for more information:

- “Set the network connection for the Lenovo XClarity Controller” on page 43
- “XCC system management port (10/100/1000 Mbps RJ-45) LEDs” on page 30

13 VGA connector

Connect a monitor to this connector.

Note: The maximum video resolution is 1920 x 1200 at 60 Hz.

14 Serial connector

Connect a 9-pin serial device to this connector. The serial port is shared with XCC. XCC can take control of the shared serial port to redirect serial traffic, using Serial over LAN (SOL).

Note: If the Serial over LAN (SOL) or Emergency Management Services (EMS) feature is enabled, the serial port will be hidden on Linux and Microsoft Windows. Therefore, it is required to disable SOL and EMS to use the serial port on operating systems for serial devices.

To enable the serial port module on Linux or Microsoft Windows, see <https://support.lenovo.com/hk/en/solutions/ht514908-how-to-enable-the-serial-port-on-thinksystem-st50-st50-v2-st250-st250-v2-sr250-and-sr250-v2-lenovo-thinksystem-sr250-v2-sr250-st250-v2-st250-st50-v2-and-st50>.

Side view

Follow the instructions in this section to locate the components from the side of the server.

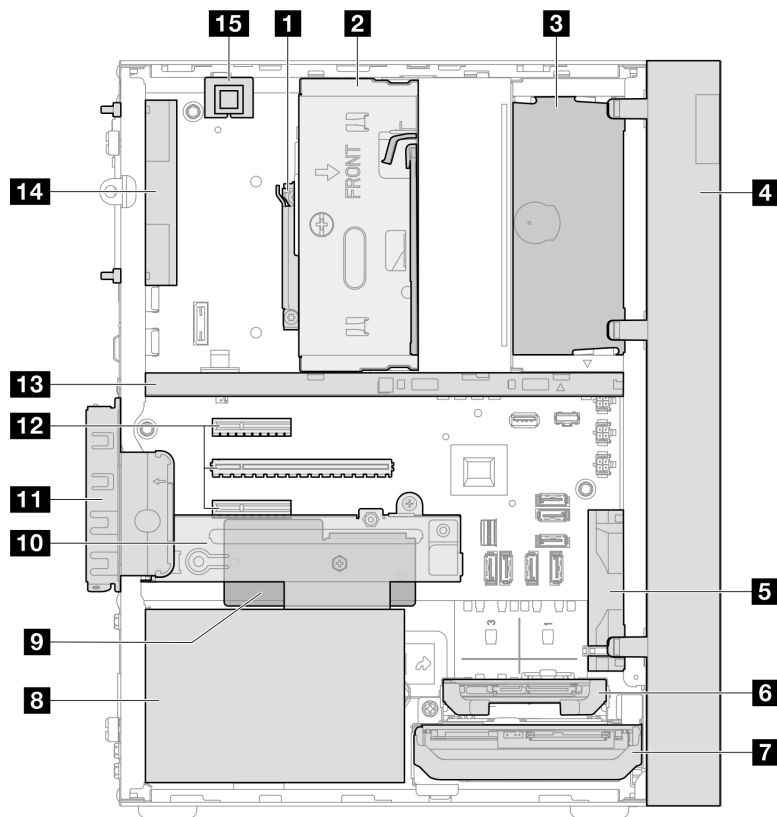

Figure 4. Side view

Table 3. Components on the side view

1 Processor	9 Firmware and RoT security module
2 Drive bay 2 (One 3.5-inch SATA drive)*	10 Drive bay 3 (One 3.5-inch SATA drive)*
3 ODD drive bay (One 9mm slim SATA Optical disk drive)*	11 PCIe adapter retainer
4 Front bezel	12 PCIe slots 1-3
5 Front fan	13 Cage bar
6 Drive bay 1 (One 2.5-inch SATA drive)*	14 Rear system 9225 fan*
7 Drive bay 0 (One 3.5-inch SATA drive)	15 Intrusion switch*
8 Fixed power supply unit	

* Optional components.

Server locks

Locking the server cover prevents unauthorized access to the inside of your server.

Padlock

Your server comes with a padlock loop. When a padlock is installed, the server cover cannot be removed.

Note: It is recommended to purchase your own padlock from a local store.

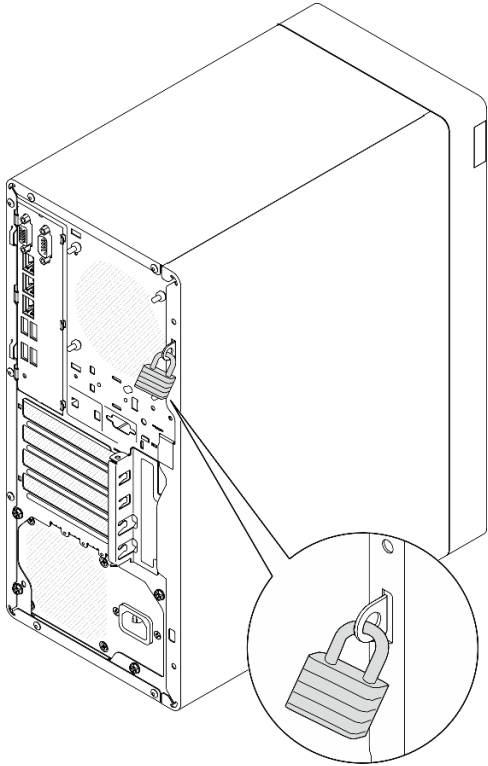

Figure 5. Padlock

Kensington-style cable lock

You can use a Kensington-style cable lock to secure your server to a desk, table, or other non-permanent fixture. The cable lock attaches to the security-lock slot at the rear of your server and is operated with a key or combination depending on the type selected. The cable lock also locks the server cover. This is the same type of lock used with many notebook computers. You can order such a cable lock directly from Lenovo by searching for **Kensington** at <http://www.lenovo.com/support>.

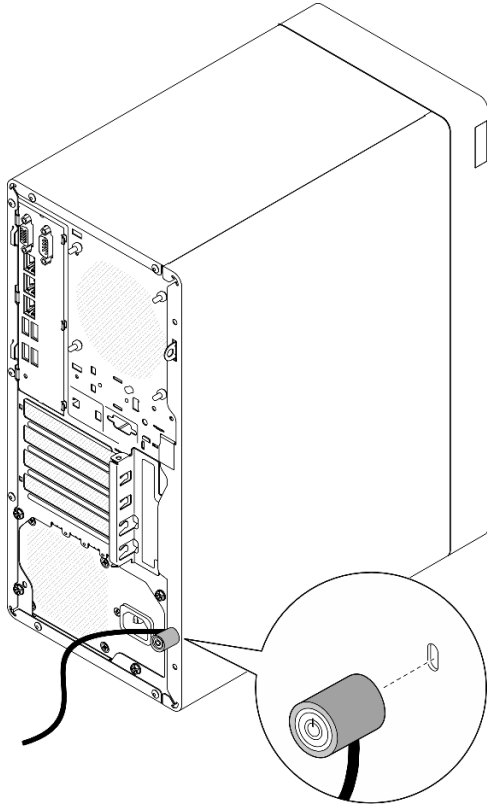

Figure 6. Kensington-style cable lock

System-board layout

The illustrations in this section provide information about the connectors, switches, and jumpers that are available on the system board.

For more information about the LEDs that are available on the system board, see [“System-board LEDs” on page 27](#).

System-board connectors

The following illustration shows the internal connectors on the system board.

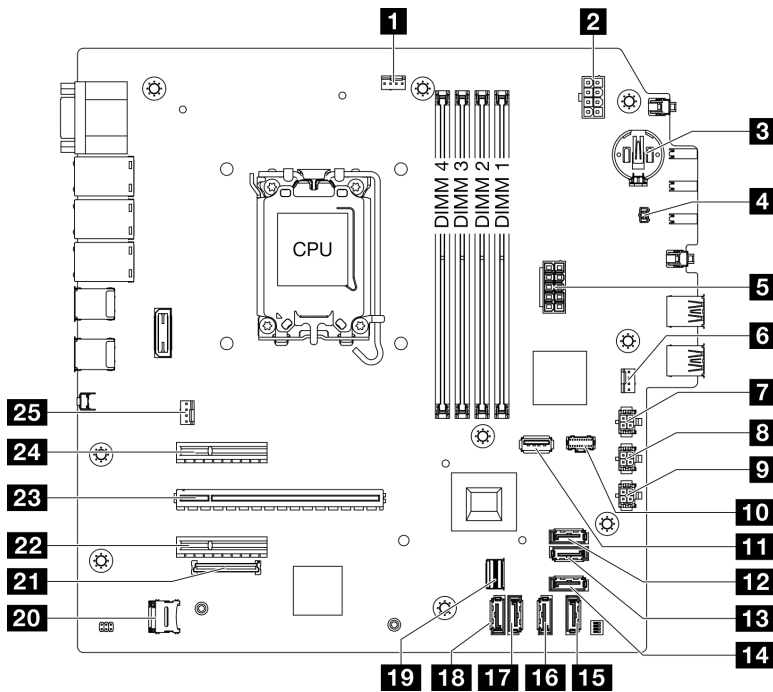

Figure 7. System-board connectors

Table 4. System-board connectors

1 Processor fan connector	14 SATA 4 connector (Slim ODD)
2 Processor power connector	15 SATA 3 connector (Bay 3)
3 3V battery (CR2032)	16 SATA 2 connector (Bay 2)
4 Intrusion switch connector	17 SATA 1 connector (Bay 1)
5 System power connector	18 SATA 0 connector (Bay 0)
6 Front fan connector	19 M.2 slimline connector
7 SATA power 3 connector	20 MicroSD socket
8 SATA power 2 connector	21 Firmware and RoT security module connector
9 SATA power 1 connector	22 PCIe slot 3
10 M.2 power connector	23 PCIe slot 2
11 USB 3.2 Gen 1 connector	24 PCIe slot 1
12 SATA 7 connector (M.2 kit)	25 Rear fan connector
13 SATA 6 connector (M.2 kit)	

System-board switches

The following illustration shows the location of the switches and jumpers on the server.

Note: If there is a clear protective sticker on the top of the switch blocks, you must remove and discard it to access the switches.

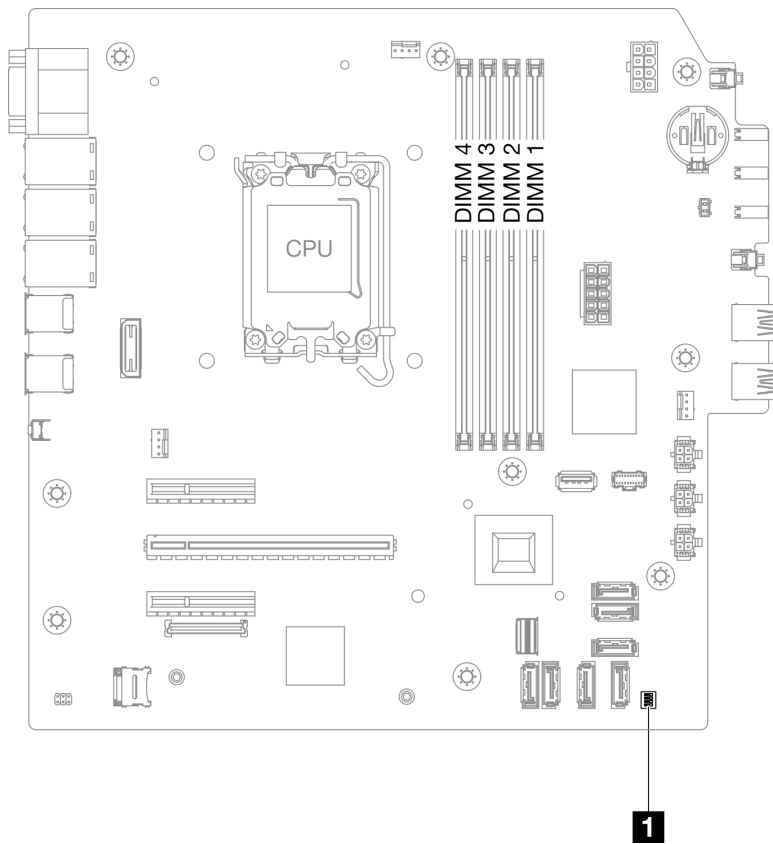

Figure 8. System-board switches

Important:

1. Before you change any switch settings or move any jumpers, turn off the server; then, disconnect all power cords and external cables. Review the following information:
 - https://pubs.lenovo.com/safety_documentation/
 - “Installation Guidelines”, “Handling static sensitive devices”, and “Power off the server ” in *User Guide* or *Hardware Maintenance Guide*.
2. Any system-board switch or jumper block that is not shown in the illustrations in this document are reserved.

SW1 switch block

The following table describes the functions of the SW1 switch block on the system board.

Switch number	Default position	Description	Definition
1	Off	Clear CMOS jumper	<ul style="list-style-type: none"> • Off: Normal (default). • On: Clear the real-time clock (RTC) registry.
2	Off	Reserved	Reserved

Switch number	Default position	Description	Definition
3	Off	Force XCC update jumper	<ul style="list-style-type: none"> Off: Normal (default). On: Force the Lenovo XClarity Controller to update to the latest version.
4	Off	Reserved	Reserved

System LEDs and diagnostics display

See the following section for information on available system LEDs and diagnostics display.

For more information, refer to [“Troubleshooting by LEDs” on page 26](#).

Troubleshooting by LEDs

See the following section for information on available LEDs.

Firmware and RoT security module LEDs

This topic provides information on LEDs of the ThinkSystem V3 Firmware and Root of Trust Security Module (firmware and RoT security module)

The following table describes the problems that are indicated by LEDs on the firmware and RoT security module.

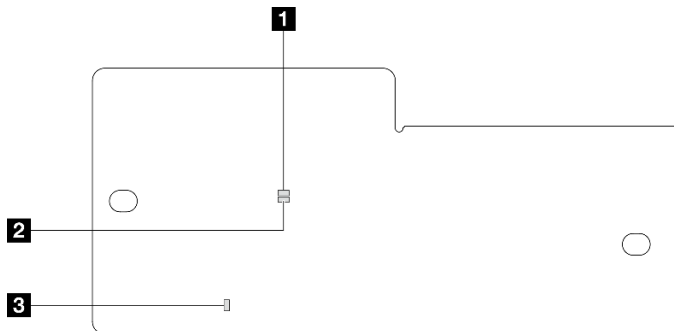

Figure 9. Firmware and RoT security module LEDs

1 AP0 LED (Green)	2 AP1 LED (Green)	3 Fatal Error LED (Amber)
--------------------------	--------------------------	----------------------------------

Table 5. LEDs description

Scenario	AP0 LED	AP1 LED	Fatal Error LED	FPGA heart-beat LED ^{note}	XCC heart-beat LED ^{note}	Actions
RoT security module fatal firmware failure	Off	Off	On	N/A	N/A	Replace the firmware and RoT security module.
	Blink	N/A	On	N/A	N/A	Replace the firmware and RoT security module.

Table 5. LEDs description (continued)

Scenario	AP0 LED	AP1 LED	Fatal Error LED	FPGA heart-beat LED ^{note}	XCC heart-beat LED ^{note}	Actions
	Blink	N/A	On	On	N/A	Replace the firmware and RoT security module.
No system power (FPGA heartbeat LED off)	Off	Off	Off	Off	Off	If the AC power is on, but the system board does not have power, then: <ol style="list-style-type: none"> 1. Check the power supply unit (PSU) or power distribution board (PDB) if any. If the PSU or PDB has any error, replace it. 2. If the PSU or PDB is good, replace the system board.
XCC firmware recoverable error	Blink	N/A	Off	N/A	N/A	Information only. No action is required.
XCC firmware is recovered from error	Blink	N/A	Off	N/A	N/A	Information only. No action is required.
UEFI firmware authentication failure	N/A	Blink	Off	N/A	N/A	Information only. No action is required.
UEFI firmware is recovered from authentication failure	N/A	On	Off	N/A	N/A	Information only. No action is required.
System is OK (FPGA heartbeat LED is On)	On	On	Off	On	On	Information only. No action is required.

System-board LEDs

The following illustrations show the light-emitting diodes (LEDs) on the system board.

Press the power button to light the LEDs on the system board when the power source has been removed from the server.

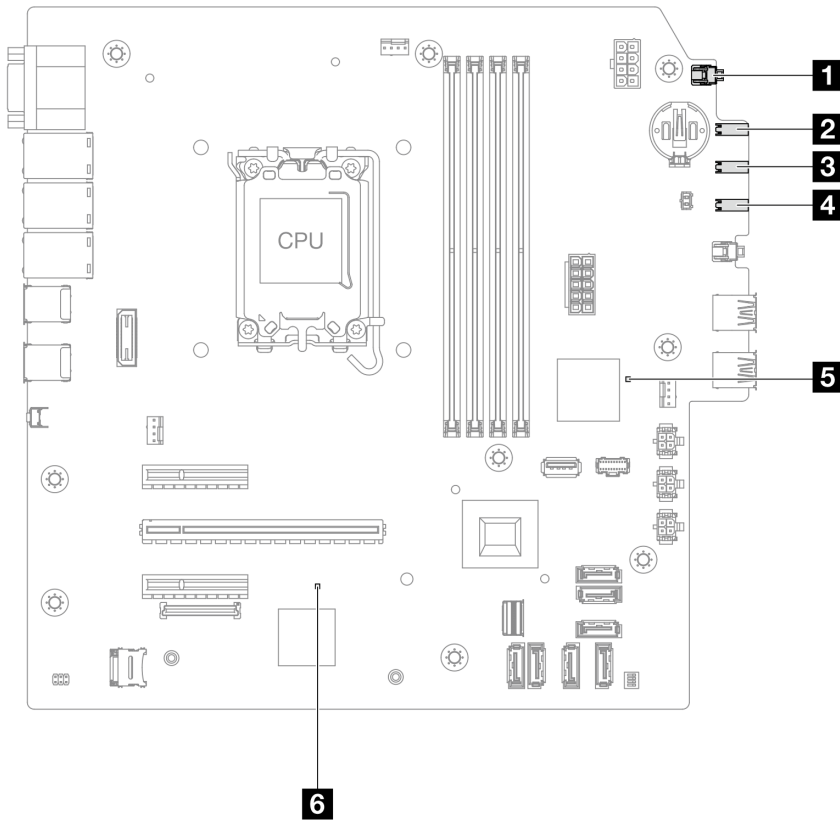

Figure 10. System-board LEDs

Table 6. System-board-assembly LEDs

LED	Description	Action
1 System power LED (green)	The system power LED helps you determine the system power status.	The states of the system power LED are as follows: <ul style="list-style-type: none"> Off: No power supply is properly installed, or the LED itself has failed. Flashing rapidly (four times per second): The server is turned off and is not ready to be turned on. The power button is disabled. This will last approximately 5 to 10 seconds. Flashing slowly (once per second): The server is turned off and is ready to be turned on. Press the power button to turn on the server. On: The server is turned on.
2 Drive activity LED (green)	This LED indicates the activity of the drives. <ul style="list-style-type: none"> Blinking: The drives are active. Off: The drives are not active. 	N/A

Table 6. System-board-assembly LEDs (continued)

LED	Description	Action
3 Network activity LED (green)	<p>The network activity LED helps you identify the network connectivity and activity.</p> <ul style="list-style-type: none"> • Blinking: The network is connected and active. • Off: The server is disconnected from the network. 	N/A
4 System error LED (yellow)	<p>The system error LED helps you determine if there are any system errors.</p> <ul style="list-style-type: none"> • On: An error has been detected on the server. • Off: The server is off or the server is on and is working correctly. 	<p>Check system logs or internal error LEDs to identify the failed part. For more information, see “System error LED” on page 16.</p>

Table 6. System-board-assembly LEDs (continued)

LED	Description	Action
5 FPGA heartbeat LED	<p>The FPGA heartbeat LED helps you identify the FPGA status.</p> <ul style="list-style-type: none"> Blinking (about one flash per second): FPGA is working normally. On or off: FPGA is not working. 	<p>If the FPGA heartbeat LED is always off or always on, do the following:</p> <ol style="list-style-type: none"> Replace the system board. If the problem remains, contact Lenovo Support.
6 XCC heartbeat LED (green)	<p>The XCC heartbeat LED helps you identify the XCC status.</p> <ul style="list-style-type: none"> Blinking (about one flash per second) : XCC is working normally. Blinking at other speeds or always on: XCC is at the initial phase or is working abnormally. Off: XCC is not working. 	<ul style="list-style-type: none"> If the XCC heartbeat LED is always off or always on, do the following: <ul style="list-style-type: none"> If XCC cannot be accessed: <ol style="list-style-type: none"> Re-plug the power cord. Check and ensure that the system board and the firmware and RoT security module are installed correctly. (Trained technician only) Reinstall them if needed. (Trained technician only) Replace the firmware and RoT security module. (Trained technician only) Replace the system board. If XCC can be accessed, replace the system board. If the XCC heartbeat LED is always blinking fast over 5 minutes, do the following: <ol style="list-style-type: none"> Re-plug the power cord. Check and ensure that the system board and the firmware and RoT security module are installed correctly. (Trained technician only) Reinstall them if needed. (Trained technician only) Replace the firmware and RoT security module. (Trained technician only) Replace the system board. If the XCC heartbeat LED is always blinking slow over 5 minutes, do the following: <ol style="list-style-type: none"> Re-plug the power cord. Check and ensure that the system board and the firmware and RoT security module are installed correctly. (Trained technician only) Reinstall them if needed. If the problem remains, contact Lenovo Support.

XCC system management port (10/100/1000 Mbps RJ-45) LEDs

This topic provides information on LEDs of XCC system management port (10/100/1000 Mbps RJ-45).

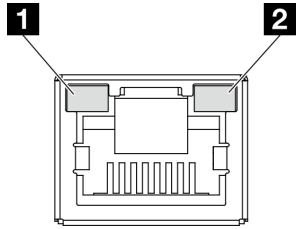

Figure 11. XCC system management port (10/100/1000 Mbps RJ-45) LEDs

LED	Description
1 XCC system management port (10/100/1000 Mbps RJ-45) link LED	Use this green LED to distinguish the network connectivity status: <ul style="list-style-type: none"> • Off: The network link is disconnected. • Green: The network link is established.
2 XCC system management port (10/100/1000 Mbps RJ-45) activity LED	Use this green LED to distinguish the network activity status: <ul style="list-style-type: none"> • Off: No data is being transmitted. • Blink: Data is being transmitted.

Chapter 3. Parts list

Identify each of the components that is available for your server with the parts list.

For more information about ordering parts:

1. Go to <http://datacentersupport.lenovo.com> and navigate to the support page for your server.
2. Click **Parts**.
3. Enter the serial number to view a listing of parts for your server.

It is highly recommended that you check the power summary data for your server using Lenovo Capacity Planner before purchasing any new parts.

Note: Depending on the model, your server might look slightly different from the illustration.

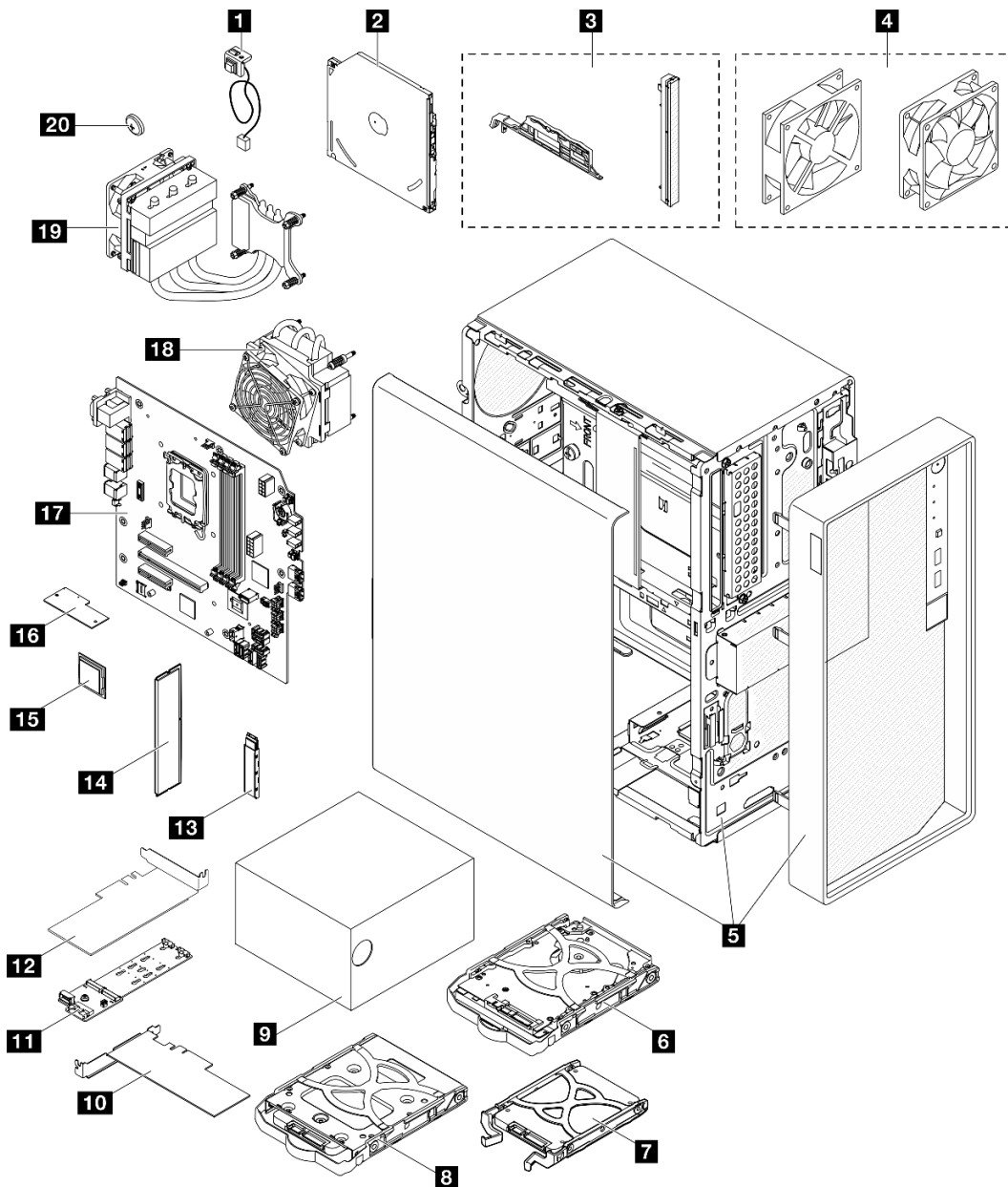

Figure 12. Server components

The parts listed in the following table are identified as one of the following:

- **T1:** Tier 1 customer replaceable unit (CRU). Replacement of Tier 1 CRUs is your responsibility. If Lenovo installs a Tier 1 CRU at your request with no service agreement, you will be charged for the installation.
- **T2:** Tier 2 customer replaceable unit (CRU). You may install a Tier 2 CRU yourself or request Lenovo to install it, at no additional charge, under the type of warranty service that is designated for your server.
- **F:** Field replaceable unit (FRU). FRUs must be installed only by trained service technicians.
- **C:** Consumable and Structural parts. Purchase and replacement of consumable and structural parts (components, such as a filler or bezel) is your responsibility. If Lenovo acquires or installs a structural component at your request, you will be charged for the service.

Description	Type	Description	Type
1 Intrusion switch	T1	2 Optical disk drive	T2
3 Bezel kit (including the optical disk drive bezel and latch)	F	4 Fan kit (including the front fan and rear fan)	T1
5 Chassis (with front bezel and server cover)	F	6 3.5-inch hard-disk drive assembly	T1
7 2.5-inch solid-state drive assembly	T1	8 3.5-inch solid-state drive assembly	T1
9 Power supply unit	T1	10 PCIe adapter	T1
11 M.2 boot adapter	T1	12 PCIe adapter for M.2 boot adapter	T1
13 M.2 drive	T1	14 Memory module	T1
15 Processor	F	16 Firmware and RoT security module	F
17 System board	F	18 Heat sink and fan module (for processor with TDP lower than 95W)	F
19 Heat sink and fan module (for processor with 95W TDP)	F	20 3V CMOS battery (CR2032)	C

Power cords

Several power cords are available, depending on the country and region where the server is installed.

To view the power cords that are available for the server:

1. Go to:
<http://dcsc.lenovo.com/#/>
2. Click **Preconfigured Model** or **Configure to order**.
3. Enter the machine type and model for your server to display the configurator page.
4. Click **Power** → **Power Cables** to see all line cords.

Notes:

- For your safety, a power cord with a grounded attachment plug is provided to use with this product. To avoid electrical shock, always use the power cord and plug with a properly grounded outlet.
- Power cords for this product that are used in the United States and Canada are listed by Underwriter's Laboratories (UL) and certified by the Canadian Standards Association (CSA).
- For units intended to be operated at 115 volts: Use a UL-listed and CSA-certified cord set consisting of a minimum 18 AWG, Type SVT or SJT, three-conductor cord, a maximum of 15 feet in length and a parallel blade, grounding-type attachment plug rated 15 amperes, 125 volts.
- For units intended to be operated at 230 volts (U.S. use): Use a UL-listed and CSA-certified cord set consisting of a minimum 18 AWG, Type SVT or SJT, three-conductor cord, a maximum of 15 feet in length and a tandem blade, grounding-type attachment plug rated 15 amperes, 250 volts.
- For units intended to be operated at 230 volts (outside the U.S.): Use a cord set with a grounding-type attachment plug. The cord set should have the appropriate safety approvals for the country in which the equipment will be installed.
- Power cords for a specific country or region are usually available only in that country or region.

Chapter 4. Unboxing and setup

Information in this section assists you on unboxing and setting up the server. When unboxing the server, check if the items in the package are correct, and learn where to find information of server serial number and Lenovo XClarity Controller access. Make sure to follow the instructions in [“Server setup checklist” on page 40](#) when setting up the server.

Server package contents

When you receive your server, verify that the shipment contains everything that you expected to receive.

The server package includes the following items:

- Server
- Keyboard*
- Material box, including items such as power cords*, accessory kit, and documentation.

Note: Items marked with asterisk (*) are available on some models only.

If any item is missing or damaged, contact your place of purchase. Ensure that you retain your proof of purchase and packing material. They might be required to receive warranty service.

Identify the server and access the Lenovo XClarity Controller

This section contains instruction on how to identify your server and where to find the Lenovo XClarity Controller access information.

Identifying your server

When you contact Lenovo for help, the machine type, model, and serial number information help support technicians to identify your server and provide faster service.

The illustration below shows the location of the ID label which contains the model number, machine type, and serial number of the server. You can also add other system information labels to the front of the server in the customer label spaces.

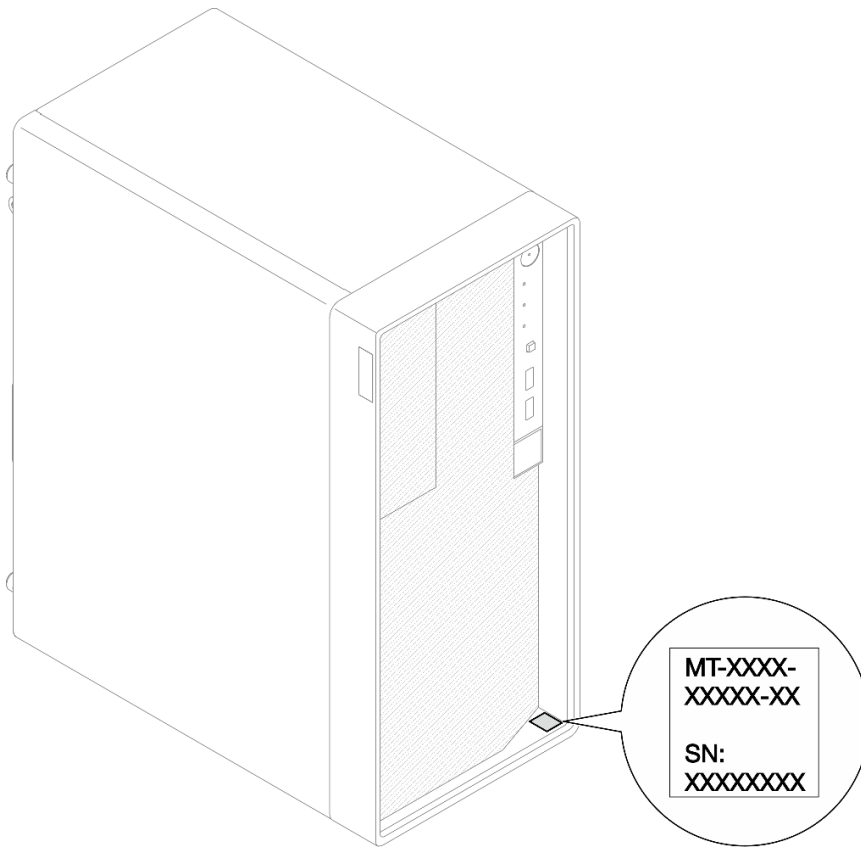

Figure 13. Location of the ID label

Lenovo XClarity Controller network access label

In addition, the Lenovo XClarity Controller network access label is attached on the top of the server. After you get the server, peel the XClarity Controller network access label away and store it in a safe place for future use.

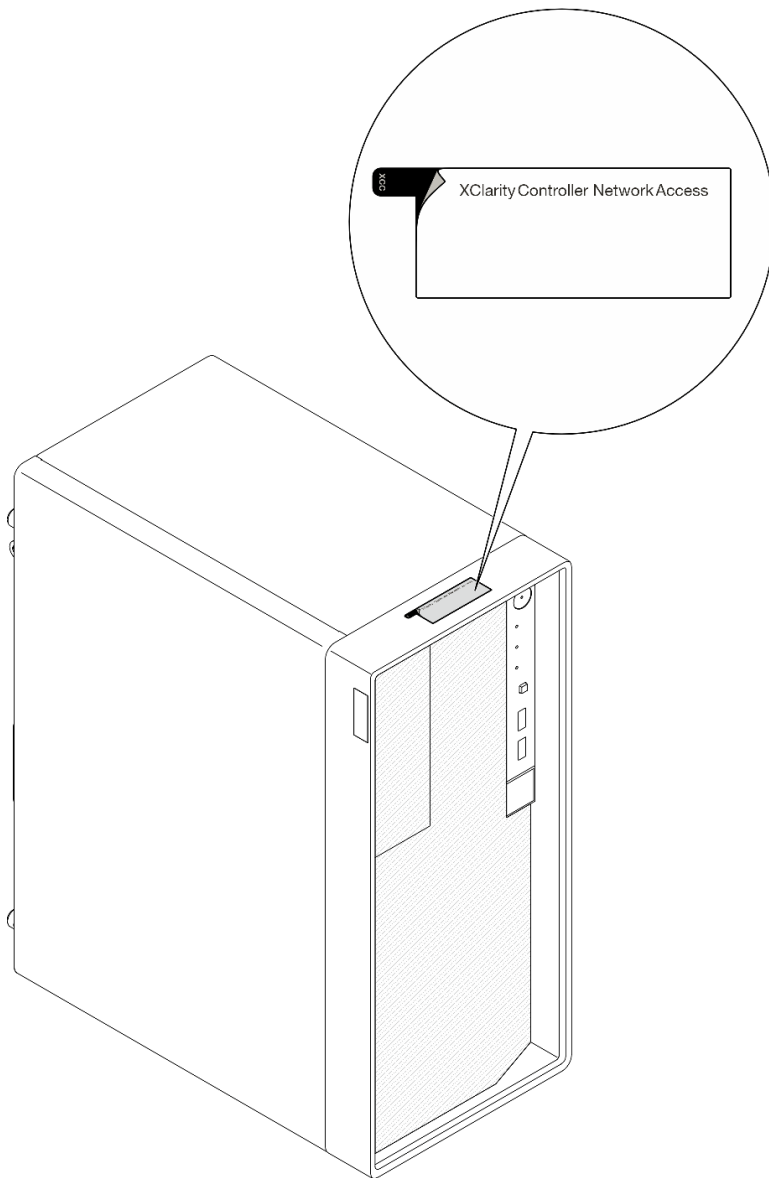

Figure 14. Location of XClarity Controller network access label

Service Label and QR code

In addition, the system Service Label is located on the inside surface of the tray cover, provides a quick reference (QR) code for mobile access to service information. You can scan the QR code with a mobile device using a QR code reader application and get quick access to the Service Information web page. The Service Information web page provides additional information for parts installation and replacement videos, and error codes for solution support.

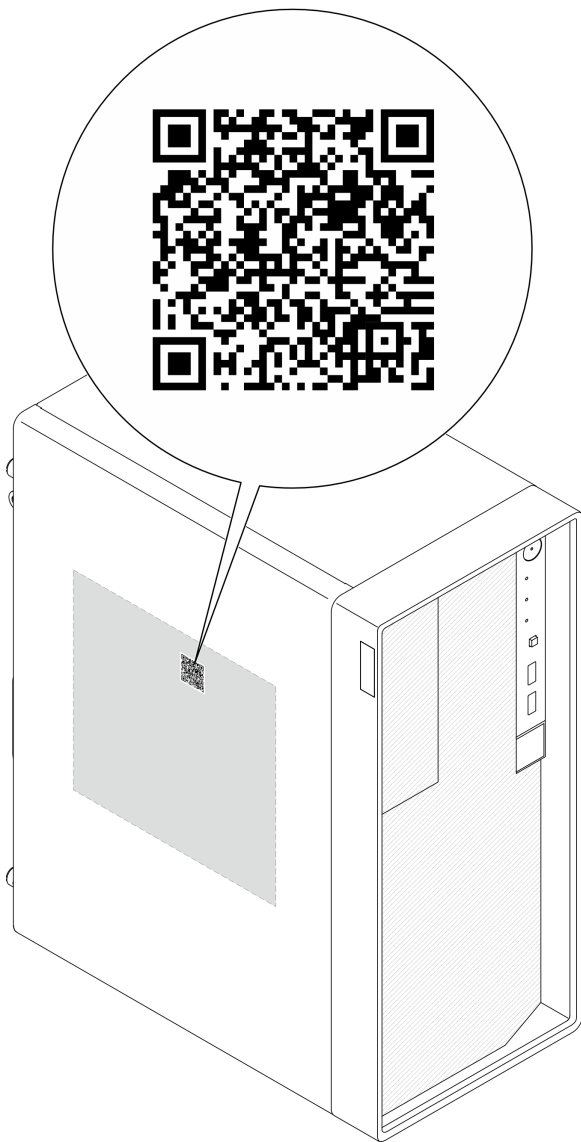

Figure 15. Service Label and QR code

Server setup checklist

Use the server setup checklist to ensure that you have performed all tasks that are required to set up your server.

The server setup procedure varies depending on the configuration of the server when it was delivered. In some cases, the server is fully configured and you just need to connect the server to the network and an AC power source, and then you can power on the server. In other cases, the server needs to have hardware options installed, requires hardware and firmware configuration, and requires an operating system to be installed.

The following steps describe the general procedure for setting up a server.

Setup the server hardware

Complete the following procedures to setup the server hardware.

1. Unpack the server package. See [“Server package contents” on page 37](#).
2. Install any required hardware or server options. See the related topics in “Hardware replacement procedures” in *User Guide* or *Hardware Maintenance Guide*.
3. If necessary, install the server into a standard rack cabinet by using the tower-to-rack conversion kit. See the documentation that comes with the optional conversion kit.
4. Connect all external cables to the server. See [Chapter 2 “Server components” on page 15](#) for connectors locations.

Typically, you will need to connect the following cables:

- Connect server to the power source
 - Connect server to the data network
 - Connect the server to the storage device
 - Connect the server to the management network
5. Power on the server.

Power button location and power LED are specified in [“Front view” on page 15](#).

The server can be turned on (power LED on) in any of the following ways:

- You can press the power button.
- The server can restart automatically after a power interruption.
- The server can respond to remote power-on requests sent to the Lenovo XClarity Controller.

Note: You can access the management processor interface to configure the system without powering on the server. Whenever the server is connected to power, the management processor interface is available. For details about accessing the management server processor, see “Opening and Using the XClarity Controller Web Interface” section in the XCC documentation compatible with your server at <https://pubs.lenovo.com/lxcc-overview/>.

6. Validate the server. Make sure that the power LED, Ethernet connector LED, and network LED are lit with green light, which means the server hardware was set up successfully.

See [“Front view” on page 15](#) and [“System LEDs and diagnostics display” on page 26](#) for more information on the LED indications.

Configure the system

Complete the following procedures to configure the system. For detailed instructions, refer to [Chapter 5 “System configuration” on page 43](#).

1. Set the network connection for the Lenovo XClarity Controller to the management network.
2. Update the firmware for the server, if necessary.
3. Configure the firmware for the server.

The following information is available for RAID configuration:

- <https://lenovopress.lenovo.com/lp0578-lenovo-raid-introduction>
 - <https://lenovopress.lenovo.com/lp0579-lenovo-raid-management-tools-and-resources>
4. Install the operating system.
 5. Back up the server configuration.
 6. Install the applications and programs for which the server is intended to be used.

Chapter 5. System configuration

Complete these procedures to configure your system.

Set the network connection for the Lenovo XClarity Controller

Before you can access the Lenovo XClarity Controller over your network, you need to specify how Lenovo XClarity Controller will connect to the network. Depending on how the network connection is implemented, you might need to specify a static IP address as well.

The following methods are available to set the network connection for the Lenovo XClarity Controller if you are not using DHCP:

- If a monitor is attached to the server, you can use Lenovo XClarity Provisioning Manager to set the network connection.

Complete the following steps to connect the Lenovo XClarity Controller to the network using the Lenovo XClarity Provisioning Manager.

1. Start the server.
2. Press the key specified in the on-screen instructions to display the Lenovo XClarity Provisioning Manager interface. (For more information, see the “Startup” section in the LXPM documentation compatible with your server at <https://pubs.lenovo.com/lxpm-overview/>.)
3. Go to **LXPM → UEFI Setup → BMC Settings** to specify how the Lenovo XClarity Controller will connect to the network.
 - If you choose a static IP connection, make sure that you specify an IPv4 or IPv6 address that is available on the network.
 - If you choose a DHCP connection, make sure that the MAC address for the server has been configured in the DHCP server.
4. Click **OK** to apply the setting and wait for two to three minutes.
5. Use an IPv4 or IPv6 address to connect Lenovo XClarity Controller.

Important: The Lenovo XClarity Controller is set initially with a user name of USERID and password of PASSWORD (with a zero, not the letter O). This default user setting has Supervisor access. It is required to change this user name and password during your initial configuration for enhanced security.

Set USB port for Lenovo XClarity Controller connection

Before you can access the Lenovo XClarity Controller through the USB port, you need to configure the USB port for Lenovo XClarity Controller connection.

Server support

To see if your server supports accessing Lenovo XClarity Controller through the USB port, check one of the following:

- Refer to [Chapter 2 “Server components” on page 15](#).



- If there is a wrench icon on the USB port of your server, you can set the management USB port to connect to Lenovo XClarity Controller. It is also the only USB port that supports USB automation update of the system I/O board (or firmware and RoT security module).

Setting the USB port for Lenovo XClarity Controller connection

You can switch the USB port between normal and Lenovo XClarity Controller management operation by performing one of the following steps.

- Hold the ID button for at least 3 seconds until its LED flashes slowly (once every couple of seconds). See [Chapter 2 “Server components” on page 15](#) for ID button location.
- From the Lenovo XClarity Controller management controller CLI, run the `usbfp` command. For information about using the Lenovo XClarity Controller CLI, see the “Command-line interface” section in the XCC documentation compatible with your server at <https://pubs.lenovo.com/lxcc-overview/>.
- From the Lenovo XClarity Controller management controller web interface, click **BMC Configuration → Network → USB Management Port Assignment**. For information about Lenovo XClarity Controller web interface functions, see the “Description of XClarity Controller functions on web interface” section in the XCC documentation compatible with your server at <https://pubs.lenovo.com/lxcc-overview/>.

Checking USB port current setting

You can also check the current setting of the USB port using the Lenovo XClarity Controller management controller CLI (`usbfp` command) or the Lenovo XClarity Controller management controller web interface (**BMC Configuration → Network → USB Management Port Assignment**). See the “Command-line interface” and “Description of XClarity Controller functions on web interface” sections in the XCC documentation compatible with your server at <https://pubs.lenovo.com/lxcc-overview/>.

Update the firmware

Several options are available to update the firmware for the server.

You can use the tools listed here to update the most current firmware for your server and the devices that are installed in the server.

- Best practices related to updating firmware is available at the following site:
 - <https://lenovopress.lenovo.com/lp0656-lenovo-thinksystem-firmware-and-driver-update-best-practices>
- The latest firmware can be found at the following site:
 - <https://datacentersupport.lenovo.com/tw/en/products/servers/thinksystem/st50v3/7df3/downloads/driver-list/>
- You can subscribe to product notification to stay up to date on firmware updates:
 - <https://datacentersupport.lenovo.com/solutions/ht509500>

Update Bundles (Service Packs)

Lenovo typically releases firmware in bundles called Update Bundles (Service Packs). To ensure that all of the firmware updates are compatible, you should update all firmware at the same time. If you are updating firmware for both the Lenovo XClarity Controller and UEFI, update the firmware for Lenovo XClarity Controller first.

Update method terminology

- **In-band update.** The installation or update is performed using a tool or application within an operating system that is executing on the server's core CPU.
- **Out-of-band update.** The installation or update is performed by the Lenovo XClarity Controller collecting the update and then directing the update to the target subsystem or device. Out-of-band updates have no dependency on an operating system executing on the core CPU. However, most out-of-band operations do require the server to be in the S0 (Working) power state.
- **On-Target update.** The installation or update is initiated from an installed operating system executing on the target server itself.
- **Off-Target update.** The installation or update is initiated from a computing device interacting directly with the server's Lenovo XClarity Controller.
- **Update Bundles (Service Packs).** Update Bundles (Service Packs) are bundled updates designed and tested to provide the interdependent level of functionality, performance, and compatibility. Update Bundles (Service Packs) are server machine-type specific and are built (with firmware and device driver updates) to support specific Windows Server, Red Hat Enterprise Linux (RHEL) and SUSE Linux Enterprise Server (SLES) operating system distributions. Machine-type-specific firmware-only Update Bundles (Service Packs) are also available.

Firmware updating tools

See the following table to determine the best Lenovo tool to use for installing and setting up the firmware:

Tool	Update Methods Supported	Core System Firmware Updates	I/O Devices Firmware Updates	Drive Firmware Updates	Graphical user interface	Command line interface	Supports Update Bundles (Service Packs)
Lenovo XClarity Provisioning Manager (LXPM)	In-band ² On-Target	√			√		
Lenovo XClarity Controller (XCC)	In-band ⁴ Out-of-band Off-Target	√	Selected I/O devices	√ ³	√		√
Lenovo XClarity Essentials OneCLI (OneCLI)	In-band Out-of-band On-Target Off-Target	√	All I/O devices	√ ³		√	√
Lenovo XClarity Essentials UpdateXpress (LXCE)	In-band Out-of-band On-Target Off-Target	√	All I/O devices		√		√

Tool	Update Methods Supported	Core System Firmware Updates	I/O Devices Firmware Updates	Drive Firmware Updates	Graphical user interface	Command line interface	Supports Update Bundles (Service Packs)
Lenovo XClarity Essentials Bootable Media Creator (BoMC)	In-band Out-of-band Off-Target	√	All I/O devices		√ (BoMC application)	√ (BoMC application)	√
Lenovo XClarity Administrator (LXCA)	In-band ¹ Out-of-band ² Off-Target	√	All I/O devices		√		√
Lenovo XClarity Integrator (LXCI) for VMware vCenter	Out-of-band Off-Target	√	Selected I/O devices		√		
Lenovo XClarity Integrator (LXCI) for Microsoft Windows Admin Center	In-band Out-of-band On-Target Off-Target	√	All I/O devices		√		√
Lenovo XClarity Integrator (LXCI) for Microsoft System Center Configuration Manager	In-band On-Target	√	All I/O devices		√		√

Notes:

1. For I/O firmware updates.
2. For BMC and UEFI firmware updates.
3. Drive firmware update is only supported by the tools and methods below:
 - XCC Bare Metal Update (BMU): In-band, and requires system reboot.
 - Lenovo XClarity Essentials OneCLI:
 - For OneCLI version earlier than 5.0.0:
 - For drives supported by ThinkSystem V2 and V3 products (legacy drives): In-band, and does not require system reboot.
 - For drives supported only by ThinkSystem V3 products (new drives): Staging to XCC and complete the update with XCC BMU (In-band, and requires system reboot.).
 - For OneCLI 5.0.0 and later versions: In-band, and does not require system reboot.
4. Bare Metal Update (BMU) only.

• **Lenovo XClarity Provisioning Manager**

From Lenovo XClarity Provisioning Manager, you can update the Lenovo XClarity Controller firmware, the UEFI firmware, and the Lenovo XClarity Provisioning Manager software.

Note: By default, the Lenovo XClarity Provisioning Manager Graphical User Interface is displayed when you start the server and press the key specified in the on-screen instructions. If you have changed that default to be the text-based system setup, you can bring up the Graphical User Interface from the text-based system setup interface.

For additional information about using Lenovo XClarity Provisioning Manager to update firmware, see:

“Firmware Update” section in the LXPM documentation compatible with your server at <https://pubs.lenovo.com/lxpm-overview/>

- **Lenovo XClarity Controller**

If you need to install a specific update, you can use the Lenovo XClarity Controller interface for a specific server.

Notes:

- To perform an in-band update through Windows or Linux, the operating system driver must be installed and the Ethernet-over-USB (sometimes called LAN over USB) interface must be enabled.

For additional information about configuring Ethernet over USB, see:

“Configuring Ethernet over USB” section in the XCC documentation version compatible with your server at <https://pubs.lenovo.com/lxcc-overview/>

- If you update firmware through the Lenovo XClarity Controller, make sure that you have downloaded and installed the latest device drivers for the operating system that is running on the server.

For additional information about using Lenovo XClarity Controller to update firmware, see:

“Updating Server Firmware” section in the XCC documentation compatible with your server at <https://pubs.lenovo.com/lxcc-overview/>

- **Lenovo XClarity Essentials OneCLI**

Lenovo XClarity Essentials OneCLI is a collection of command line applications that can be used to manage Lenovo servers. Its update application can be used to update firmware and device drivers for your servers. The update can be performed within the host operating system of the server (in-band) or remotely through the BMC of the server (out-of-band).

For additional information about using Lenovo XClarity Essentials OneCLI to update firmware, see:

https://pubs.lenovo.com/lxce-onecli/onecli_c_update

- **Lenovo XClarity Essentials UpdateXpress**

Lenovo XClarity Essentials UpdateXpress provides most of OneCLI update functions through a graphical user interface (GUI). It can be used to acquire and deploy Update Bundles (Service Packs) update packages and individual updates. Update Bundles (Service Packs) contain firmware and device driver updates for Microsoft Windows and for Linux.

You can obtain Lenovo XClarity Essentials UpdateXpress from the following location:

<https://datacentersupport.lenovo.com/solutions/lnvo-xpress>

- **Lenovo XClarity Essentials Bootable Media Creator**

You can use Lenovo XClarity Essentials Bootable Media Creator to create bootable media that is suitable for firmware updates, VPD updates, inventory and FFDC collection, advanced system configuration, FoD Keys management, secure erase, RAID configuration, and diagnostics on supported servers.

You can obtain Lenovo XClarity Essentials BoMC from the following location:

<https://datacentersupport.lenovo.com/solutions/lnvo-bomc>

- **Lenovo XClarity Administrator**

If you are managing multiple servers using the Lenovo XClarity Administrator, you can update firmware for all managed servers through that interface. Firmware management is simplified by assigning firmware-compliance policies to managed endpoints. When you create and assign a compliance policy to managed endpoints, Lenovo XClarity Administrator monitors changes to the inventory for those endpoints and flags any endpoints that are out of compliance.

For additional information about using Lenovo XClarity Administrator to update firmware, see:

https://pubs.lenovo.com/lxca/update_fw

- **Lenovo XClarity Integrator offerings**

Lenovo XClarity Integrator offerings can integrate management features of Lenovo XClarity Administrator and your server with software used in a certain deployment infrastructure, such as VMware vCenter, Microsoft Admin Center, or Microsoft System Center.

For additional information about using Lenovo XClarity Integrator to update firmware, see:

<https://pubs.lenovo.com/lxci-overview/>

Configure the firmware

Several options are available to install and set up the firmware for the server.

Important: Lenovo does not recommend setting option ROMs to **Legacy**, but you can conduct this setting if necessary. Note that this setting prevents UEFI drivers for the slot devices from loading, which may cause negative side effects to Lenovo software, such as LXCA, OneCLI, and XCC. These side effects include but are not limited to the inability to determine adapter card details, such as model name and firmware levels. For example, "ThinkSystem RAID 930-16i 4GB Flash" may be displayed as "Adapter 06:00:00". In some cases, the functionality on a specific PCIe adapter may not be enabled properly.

- **Lenovo XClarity Provisioning Manager (LXPM)**

From Lenovo XClarity Provisioning Manager, you can configure the UEFI settings for your server.

Notes: The Lenovo XClarity Provisioning Manager provides a Graphical User Interface to configure a server. The text-based interface to system configuration (the Setup Utility) is also available. From Lenovo XClarity Provisioning Manager, you can choose to restart the server and access the text-based interface. In addition, you can choose to make the text-based interface the default interface that is displayed when you start LXPM. To do this, go to **Lenovo XClarity Provisioning Manager → UEFI Setup → System Settings → <F1>Start Control → Text Setup**. To start the server with Graphic User Interface, select **Auto** or **Tool Suite**.

See the following documentations for more information:

- Search for the LXPM documentation version compatible with your server at <https://pubs.lenovo.com/lxpm-overview/>
- *UEFI User Guide* at <https://pubs.lenovo.com/uefi-overview/>

- **Lenovo XClarity Essentials OneCLI**

You can use the config application and commands to view the current system configuration settings and make changes to Lenovo XClarity Controller and UEFI. The saved configuration information can be used to replicate or restore other systems.

For information about configuring the server using Lenovo XClarity Essentials OneCLI, see:

https://pubs.lenovo.com/lxce-onecli/onecli_c_settings_info_commands

- **Lenovo XClarity Administrator**

You can quickly provision and pre-provision all of your servers using a consistent configuration. Configuration settings (such as local storage, I/O adapters, boot settings, firmware, ports, and Lenovo XClarity Controller and UEFI settings) are saved as a server pattern that can be applied to one or more managed servers. When the server patterns are updated, the changes are automatically deployed to the applied servers.

Specific details about updating firmware using Lenovo XClarity Administrator are available at:

https://pubs.lenovo.com/lxca/server_configuring

- **Lenovo XClarity Controller**

You can configure the management processor for the server through the Lenovo XClarity Controller Web interface, the command-line interface, or Redfish API.

For information about configuring the server using Lenovo XClarity Controller, see:

“Configuring the Server” section in the XCC documentation compatible with your server at <https://pubs.lenovo.com/lxcc-overview/>

Memory module configuration

Memory performance depends on several variables, such as memory mode, memory speed, memory ranks, memory population and processor.

Information about optimizing memory performance and configuring memory is available at the Lenovo Press website:

<https://lenovopress.lenovo.com/servers/options/memory>

In addition, you can take advantage of a memory configurator, which is available at the following site:

https://dcsc.lenovo.com/#/memory_configuration

RAID configuration

Using a Redundant Array of Independent Disks (RAID) to store data remains one of the most common and cost-efficient methods to increase server's storage performance, availability, and capacity.

RAID increases performance by allowing multiple drives to process I/O requests simultaneously. RAID can also prevent data loss in case of a drive failure by reconstructing (or rebuilding) the missing data from the failed drive using the data from the remaining drives.

RAID array (also known as RAID drive group) is a group of multiple physical drives that uses a certain common method to distribute data across the drives. A virtual drive (also known as virtual disk or logical drive) is a partition in the drive group that is made up of contiguous data segments on the drives. Virtual drive is presented up to the host operating system as a physical disk that can be partitioned to create OS logical drives or volumes.

An introduction to RAID is available at the following Lenovo Press website:

<https://lenovopress.lenovo.com/lp0578-lenovo-raid-introduction>

Detailed information about RAID management tools and resources is available at the following Lenovo Press website:

<https://lenovopress.lenovo.com/lp0579-lenovo-raid-management-tools-and-resources>

Intel VROC

Enabling Intel VROC

Before setting up RAID for NVMe drives, follow the below steps to enable VROC:

1. Restart the system. Before the operating system starts up, press the key specified in the on-screen instructions to enter the Setup Utility. (For more information, see the “Startup” section in the LXPM documentation compatible with your server at <https://pubs.lenovo.com/lxpm-overview/>.)
2. Go to **System settings → Devices and I/O Ports → Onboard SATA Mode → RAID** and enable the option.
3. Save the changes and reboot the system.

Intel VROC configurations

Intel offers various VROC configurations with different RAID level and SSD support. See the following for more details.

Notes:

- Supported RAID levels varies by model. For the RAID level supported by ST50 V3, see “[Technical specifications](#)” on page 3.
- For more information about acquiring and installing the activation key, see <https://fod.lenovo.com/lkms>.

Intel VROC configurations for SATA SSDs	Requirements
Intel VROC SATA RAID	<ul style="list-style-type: none">• Supports RAID levels 0, 1, and 5.

Deploy the operating system

Several options are available to deploy an operating system on the server.

Available operating systems

- Microsoft Windows Server
- VMware ESXi
- Red Hat Enterprise Linux
- SUSE Linux Enterprise Server

Complete list of available operating systems: <https://lenovopress.lenovo.com/osig>.

Tool-based deployment

- **Multi-server**

Available tools:

- Lenovo XClarity Administrator
https://pubs.lenovo.com/lxca/compute_node_image_deployment
- Lenovo XClarity Essentials OneCLI
https://pubs.lenovo.com/lxce-onecli/onecli_r_uxspi_proxy_tool
- Lenovo XClarity Integrator deployment pack for SCCM (for Windows operating system only)
https://pubs.lenovo.com/lxci-deploypack-sccm/dpsccm_c_endtoend_deploy_scenario

- **Single-server**

Available tools:

- Lenovo XClarity Provisioning Manager
“OS Installation” section in the LXPM documentation compatible with your server at <https://pubs.lenovo.com/lxpm-overview/>
- Lenovo XClarity Essentials OneCLI
https://pubs.lenovo.com/lxce-onecli/onecli_r_uxspi_proxy_tool
- Lenovo XClarity Integrator deployment pack for SCCM (for Windows operating system only)
https://pubs.lenovo.com/lxci-deploypack-sccm/dpsccm_c_endtoend_deploy_scenario

Manual deployment

If you cannot access the above tools, follow the instructions below, download the corresponding *OS Installation Guide*, and deploy the operating system manually by referring to the guide.

1. Go to <https://datacentersupport.lenovo.com/solutions/server-os>.
2. Select an operating system from the navigation pane and click **Resources**.
3. Locate the “OS Install Guides” area and click the installation instructions. Then, follow the instructions to complete the operation system deployment task.

Back up the server configuration

After setting up the server or making changes to the configuration, it is a good practice to make a complete backup of the server configuration.

Make sure that you create backups for the following server components:

- **Management processor**

You can back up the management processor configuration through the Lenovo XClarity Controller interface. For details about backing up the management processor configuration, see:

“Backing up the BMC configuration” section in the XCC documentation compatible with your server at <https://pubs.lenovo.com/lxcc-overview/>.

Alternatively, you can use the `save` command from Lenovo XClarity Essentials OneCLI to create a backup of all configuration settings. For more information about the `save` command, see:

https://pubs.lenovo.com/lxce-onecli/onecli_r_save_command

- **Operating system**

Use your backup methods to back up the operating system and user data for the server.

Appendix A. Getting help and technical assistance

If you need help, service, or technical assistance or just want more information about Lenovo products, you will find a wide variety of sources available from Lenovo to assist you.

On the World Wide Web, up-to-date information about Lenovo systems, optional devices, services, and support are available at:

<http://datacentersupport.lenovo.com>

Note: IBM is Lenovo's preferred service provider for ThinkSystem.

Before you call

Before you call, there are several steps that you can take to try and solve the problem yourself. If you decide that you do need to call for assistance, gather the information that will be needed by the service technician to more quickly resolve your problem.

Attempt to resolve the problem yourself

You can solve many problems without outside assistance by following the troubleshooting procedures that Lenovo provides in the online help or in the Lenovo product documentation. The online help also describes the diagnostic tests that you can perform. The documentation for most systems, operating systems, and programs contains troubleshooting procedures and explanations of error messages and error codes. If you suspect a software problem, see the documentation for the operating system or program.

You can find the product documentation for your ThinkSystem products at the following location:

<https://pubs.lenovo.com/>

You can take these steps to try to solve the problem yourself:

- Check all cables to make sure that they are connected.
- Check the power switches to make sure that the system and any optional devices are turned on.
- Check for updated software, firmware, and operating-system device drivers for your Lenovo product. (See the following links) The Lenovo Warranty terms and conditions state that you, the owner of the Lenovo product, are responsible for maintaining and updating all software and firmware for the product (unless it is covered by an additional maintenance contract). Your service technician will request that you upgrade your software and firmware if the problem has a documented solution within a software upgrade.
 - Drivers and software downloads
 - <https://datacentersupport.lenovo.com/tw/en/products/servers/thinksystem/st50v3/7df3/downloads/driver-list/>
 - Operating system support center
 - <https://datacentersupport.lenovo.com/solutions/server-os>
 - Operating system installing instructions
 - <https://pubs.lenovo.com/thinksystem#os-installation>
- If you have installed new hardware or software in your environment, check <https://serverproven.lenovo.com> to make sure that the hardware and software are supported by your product.
- Refer to “Problem Determination” in *User Guide* or *Hardware Maintenance Guide* for instructions on isolating and solving issues.

- Go to <http://datacentersupport.lenovo.com> and check for information to help you solve the problem.

To find the Tech Tips available for your server:

1. Go to <http://datacentersupport.lenovo.com> and navigate to the support page for your server.
2. Click on **How To's** from the navigation pane.
3. Click **Article Type** → **Solution** from the drop-down menu.

Follow the on-screen instructions to choose the category for the problem that you are having.

- Check Lenovo Data Center Forum at https://forums.lenovo.com/t5/Datacenter-Systems/ct-p/sv_eg to see if someone else has encountered a similar problem.

Gathering information needed to call Support

If you require warranty service for your Lenovo product, the service technicians will be able to assist you more efficiently if you prepare the appropriate information before you call. You can also go to <http://datacentersupport.lenovo.com/warrantylookup> for more information about your product warranty.

Gather the following information to provide to the service technician. This data will help the service technician quickly provide a solution to your problem and ensure that you receive the level of service for which you might have contracted.

- Hardware and Software Maintenance agreement contract numbers, if applicable
- Machine type number (Lenovo 4-digit machine identifier). Machine type number can be found on the ID label, see “[Identify the server and access the Lenovo XClarity Controller](#)” on page 37.
- Model number
- Serial number
- Current system UEFI and firmware levels
- Other pertinent information such as error messages and logs

As an alternative to calling Lenovo Support, you can go to <https://support.lenovo.com/servicerequest> to submit an Electronic Service Request. Submitting an Electronic Service Request will start the process of determining a solution to your problem by making the pertinent information available to the service technicians. The Lenovo service technicians can start working on your solution as soon as you have completed and submitted an Electronic Service Request.

Collecting service data

To clearly identify the root cause of a server issue or at the request of Lenovo Support, you might need collect service data that can be used for further analysis. Service data includes information such as event logs and hardware inventory.

Service data can be collected through the following tools:

- **Lenovo XClarity Provisioning Manager**

Use the Collect Service Data function of Lenovo XClarity Provisioning Manager to collect system service data. You can collect existing system log data or run a new diagnostic to collect new data.

- **Lenovo XClarity Controller**

You can use the Lenovo XClarity Controller web interface or the CLI to collect service data for the server. The file can be saved and sent to Lenovo Support.

- For more information about using the web interface to collect service data, see the “Backing up the BMC configuration” section in the XCC documentation compatible with your server at <https://pubs.lenovo.com/lxcc-overview/>.

- For more information about using the CLI to collect service data, see the “XCC `ffdc` command” section in the XCC documentation compatible with your server at <https://pubs.lenovo.com/lxcc-overview/>.

- **Lenovo XClarity Administrator**

Lenovo XClarity Administrator can be set up to collect and send diagnostic files automatically to Lenovo Support when certain serviceable events occur in Lenovo XClarity Administrator and the managed endpoints. You can choose to send diagnostic files to Lenovo Support using Call Home or to another service provider using SFTP. You can also manually collect diagnostic files, open a problem record, and send diagnostic files to the Lenovo Support.

You can find more information about setting up automatic problem notification within the Lenovo XClarity Administrator at https://pubs.lenovo.com/lxca/admin_setupcallhome.

- **Lenovo XClarity Essentials OneCLI**

Lenovo XClarity Essentials OneCLI has inventory application to collect service data. It can run both in-band and out-of-band. When running in-band within the host operating system on the server, OneCLI can collect information about the operating system, such as the operating system event log, in addition to the hardware service data.

To obtain service data, you can run the `getinfor` command. For more information about running the `getinfor`, see https://pubs.lenovo.com/lxce-onecli/onecli_r_getinfor_command.

Contacting Support

You can contact Support to obtain help for your issue.

You can receive hardware service through a Lenovo Authorized Service Provider. To locate a service provider authorized by Lenovo to provide warranty service, go to <https://datacentersupport.lenovo.com/serviceprovider> and use filter searching for different countries. For Lenovo support telephone numbers, see <https://datacentersupport.lenovo.com/supportphonenumberlist> for your region support details.

Appendix B. Documents and supports

This section provides handy documents, driver and firmware downloads, and support resources.

Documents download

This section provides introduction and download link for handy documents.

Documents

Download the following product documentations at:

https://pubs.lenovo.com/st50-v3/pdf_files.html

- **Rail Installation Guides**
 - Rail installation in a rack
- **User Guide**
 - Complete overview, system configuration, hardware components replacing, and troubleshooting.
Selected chapters from *User Guide*:
 - **System Configuration Guide** : Server overview, components identification, system LEDs and diagnostics display, product unboxing, setting up and configuring the server.
 - **Hardware Maintenance Guide** : Installing hardware components, cable routing, and troubleshooting.
- **Messages and Codes Reference**
 - XClarity Controller, LXPM, and uEFI events
- **UEFI Manual**
 - UEFI setting introduction

Support websites

This section provides driver and firmware downloads and support resources.

Support and downloads

- Drivers and Software download website for ThinkSystem ST50 V3
 - <https://datacentersupport.lenovo.com/tw/en/products/servers/thinksystem/st50v3/7df3/downloads/driver-list/>
- Lenovo Data Center Forum
 - https://forums.lenovo.com/t5/Datacenter-Systems/ct-p/sv_eg
- Lenovo Data Center Support for ThinkSystem ST50 V3
 - <https://datacentersupport.lenovo.com/products/servers/thinksystem/st50v3/7df3>
- Lenovo License Information Documents
 - <https://datacentersupport.lenovo.com/documents/Invo-eula>
- Lenovo Press website (Product Guides/Datasheets/White papers)
 - <https://lenovopress.lenovo.com/>

- Lenovo Privacy Statement
 - <https://www.lenovo.com/privacy>
- Lenovo Product Security Advisories
 - https://datacentersupport.lenovo.com/product_security/home
- Lenovo Product Warranty Plans
 - <http://datacentersupport.lenovo.com/warrantylookup>
- Lenovo Server Operating Systems Support Center website
 - <https://datacentersupport.lenovo.com/solutions/server-os>
- Lenovo ServerProven website (Options compatibility lookup)
 - <https://serverproven.lenovo.com>
- Operating System Installation Instructions
 - <https://pubs.lenovo.com/thinksystem#os-installation>
- Submit an eTicket (service request)
 - <https://support.lenovo.com/servicerequest>
- Subscribe to Lenovo Data Center Group product notifications (Stay up to date on firmware updates)
 - <https://datacentersupport.lenovo.com/solutions/ht509500>

Appendix C. Notices

Lenovo may not offer the products, services, or features discussed in this document in all countries. Consult your local Lenovo representative for information on the products and services currently available in your area.

Any reference to a Lenovo product, program, or service is not intended to state or imply that only that Lenovo product, program, or service may be used. Any functionally equivalent product, program, or service that does not infringe any Lenovo intellectual property right may be used instead. However, it is the user's responsibility to evaluate and verify the operation of any other product, program, or service.

Lenovo may have patents or pending patent applications covering subject matter described in this document. The furnishing of this document is not an offer and does not provide a license under any patents or patent applications. You can send inquiries in writing to the following:

*Lenovo (United States), Inc.
8001 Development Drive
Morrisville, NC 27560
U.S.A.
Attention: Lenovo Director of Licensing*

LENOVO PROVIDES THIS PUBLICATION "AS IS" WITHOUT WARRANTY OF ANY KIND, EITHER EXPRESS OR IMPLIED, INCLUDING, BUT NOT LIMITED TO, THE IMPLIED WARRANTIES OF NON-INFRINGEMENT, MERCHANTABILITY OR FITNESS FOR A PARTICULAR PURPOSE. Some jurisdictions do not allow disclaimer of express or implied warranties in certain transactions, therefore, this statement may not apply to you.

This information could include technical inaccuracies or typographical errors. Changes are periodically made to the information herein; these changes will be incorporated in new editions of the publication. Lenovo may make improvements and/or changes in the product(s) and/or the program(s) described in this publication at any time without notice.

The products described in this document are not intended for use in implantation or other life support applications where malfunction may result in injury or death to persons. The information contained in this document does not affect or change Lenovo product specifications or warranties. Nothing in this document shall operate as an express or implied license or indemnity under the intellectual property rights of Lenovo or third parties. All information contained in this document was obtained in specific environments and is presented as an illustration. The result obtained in other operating environments may vary.

Lenovo may use or distribute any of the information you supply in any way it believes appropriate without incurring any obligation to you.

Any references in this publication to non-Lenovo Web sites are provided for convenience only and do not in any manner serve as an endorsement of those Web sites. The materials at those Web sites are not part of the materials for this Lenovo product, and use of those Web sites is at your own risk.

Any performance data contained herein was determined in a controlled environment. Therefore, the result obtained in other operating environments may vary significantly. Some measurements may have been made on development-level systems and there is no guarantee that these measurements will be the same on generally available systems. Furthermore, some measurements may have been estimated through extrapolation. Actual results may vary. Users of this document should verify the applicable data for their specific environment.

Trademarks

LENOVO and THINKSYSTEM are trademarks of Lenovo.

All other trademarks are the property of their respective owners.

Important notes

Processor speed indicates the internal clock speed of the processor; other factors also affect application performance.

CD or DVD drive speed is the variable read rate. Actual speeds vary and are often less than the possible maximum.

When referring to processor storage, real and virtual storage, or channel volume, KB stands for 1 024 bytes, MB stands for 1 048 576 bytes, and GB stands for 1 073 741 824 bytes.

When referring to hard disk drive capacity or communications volume, MB stands for 1 000 000 bytes, and GB stands for 1 000 000 000 bytes. Total user-accessible capacity can vary depending on operating environments.

Maximum internal hard disk drive capacities assume the replacement of any standard hard disk drives and population of all hard-disk-drive bays with the largest currently supported drives that are available from Lenovo.

Maximum memory might require replacement of the standard memory with an optional memory module.

Each solid-state memory cell has an intrinsic, finite number of write cycles that the cell can incur. Therefore, a solid-state device has a maximum number of write cycles that it can be subjected to, expressed as total bytes written (TBW). A device that has exceeded this limit might fail to respond to system-generated commands or might be incapable of being written to. Lenovo is not responsible for replacement of a device that has exceeded its maximum guaranteed number of program/erase cycles, as documented in the Official Published Specifications for the device.

Lenovo makes no representations or warranties with respect to non-Lenovo products. Support (if any) for the non-Lenovo products is provided by the third party, not Lenovo.

Some software might differ from its retail version (if available) and might not include user manuals or all program functionality.

Electronic emission notices

When you attach a monitor to the equipment, you must use the designated monitor cable and any interference suppression devices that are supplied with the monitor.

Additional electronic emissions notices are available at:

https://pubs.lenovo.com/important_notices/

Taiwan Region BSMI RoHS declaration

單元 Unit	限用物質及其化學符號 Restricted substances and its chemical symbols					
	鉛Lead (Pb)	汞Mercury (Hg)	鎘Cadmium (Cd)	六價鉻 Hexavalent chromium (Cr ⁶⁺)	多溴聯苯 Polybrominated biphenyls (PBB)	多溴二苯醚 Polybrominated diphenyl ethers (PBDE)
機架	○	○	○	○	○	○
外部蓋板	○	○	○	○	○	○
機械組零件	-	○	○	○	○	○
空氣傳動設備	-	○	○	○	○	○
冷卻組零件	-	○	○	○	○	○
內存模組	-	○	○	○	○	○
處理器模組	-	○	○	○	○	○
電纜組零件	-	○	○	○	○	○
電源供應器	-	○	○	○	○	○
儲備設備	-	○	○	○	○	○
印刷電路板	-	○	○	○	○	○

備考1. “超出0.1 wt %”及“超出0.01 wt %”係指限用物質之百分比含量超出百分比含量基準值。
Note1: “exceeding 0.1wt%” and “exceeding 0.01 wt%” indicate that the percentage content of the restricted substance exceeds the reference percentage value of presence condition.

備考2. “○”係指該項限用物質之百分比含量未超出百分比含量基準值。
Note2: “○”indicates that the percentage content of the restricted substance does not exceed the percentage of reference value of presence.

備考3. “-”係指該項限用物質為排除項目。
Note3: The “-” indicates that the restricted substance corresponds to the exemption.

Taiwan Region import and export contact information

Contacts are available for Taiwan Region import and export information.

委製商/進口商名稱: 台灣聯想環球科技股份有限公司
進口商地址: 台北市南港區三重路 66 號 8 樓
進口商電話: 0800-000-702

Lenovo